

Sliding Contact Sensor Unit Program 0811

Order number

4-pole: 08-V015-0498 (3252898)

6-pole: 08-V015-0112 (77393)

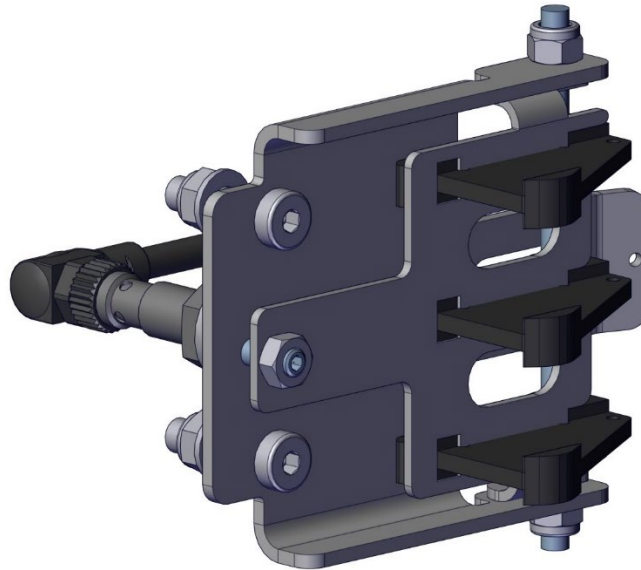

4-pole

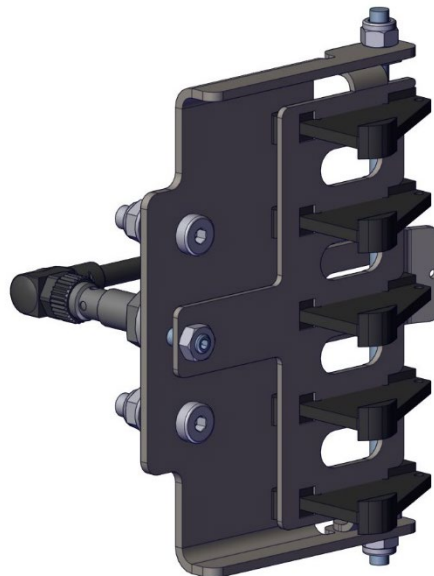

6-pole

Sliding Contact Sensor Unit

Program 0811

Contents

1	General Notes.....	5
1.1	Information on these operating instructions.....	5
1.2	Limitation of liability	5
1.3	Copyright	5
1.4	Spare parts	6
1.5	Material defects	6
1.6	Technical support	6
2	Safety Instructions	6
2.1	Explication of symbols	6
2.2	Requirements to the personnel	8
2.2.1	Qualification.....	8
2.2.2	Unauthorized personnel	8
2.2.3	Instruction	8
2.3	Personal protective equipment.....	9
2.4	Intended use.....	10
2.5	Protective measures by the operator / user.....	10
2.6	5 safety rules for working on electrical equipment.....	11
2.7	Special hazards	12
2.7.1	Electrical hazards and sources of danger	12
2.7.2	Mechanical hazards and sources of danger.....	13
2.7.3	Danger due to dust and vapors	13
2.8	Actions in the event of accidents and disturbances.....	14
3	Technical Data	15
3.1	General information	15
3.2	Electrical interface	15
3.3	Operating conditions.....	16

Sliding Contact Sensor Unit

Program 0811

4	Product Description and Mode of Operation	17
4.1	Short description.....	17
4.2	Design and mode of operation of inductive sensors.....	17
4.3	Function of the sliding contact sensor unit	18
4.4	The output signal	18
4.5	Prerequisite for reliable evaluation	19
4.6	Possibilities for impulse extension.....	20
4.7	Evaluation logic	20
5	Transport, Packaging and Storage	21
5.1	Transport	21
5.1.1	Transport inspection	21
5.2	Packaging.....	21
5.3	Storage of the packages.....	22
6	Assembly and Commissioning	23
6.1	Safety	23
6.2	Preparations	25
6.3	Assembly	26
6.3.1	Installation of the sliding contact sensor unit.....	27
6.3.2	Electrical connection.....	30
6.4	Testing and initial commissioning.....	31
6.4.1	Test list for initial commissioning	31
6.4.2	Perform initial commissioning	31
7	Operation	32
7.1	Safety	32
8	Maintenance and Servicing.....	33
8.1	Safety	33
8.2	Maintenance schedule.....	34
9	Fault Diagnosis	35

Sliding Contact Sensor Unit Program 0811

10	Disassembly and Disposal	37
10.1	Safety	37
10.2	Disassembly	38
10.2.1	Dismounting the assembly	38
10.3	Disposal	38
11	Additional Documents	39
11.1	Applicable documents	39
12	Index	39
13	Appendix Program Example (Contact Diagram)	40

Sliding Contact Sensor Unit

Program 0811

1 General Notes

1.1 Information on these Operating Instructions

These operating instructions allow the safe and efficient handling of the equipment.

These operating instructions are part of the unit and must be stored close to the unit and always available to the personnel. The personnel must have carefully read and understood these operating instructions prior to starting any works. The basic requirement for safe working is the compliance with all the safety notes and handling instructions listed in these operating instructions.

Add the operating instructions to your system documentation as well as to the maintenance documentations.

Moreover, the local accident prevention regulations and general safety regulations for the range of application must be observed. Illustrations in this documentation are for basic comprehension and may differ from the present product.

1.2 Limitation of Liability

All information and notes in these operating instructions have been compiled regarding the applicable standards and regulations, state of technology and the findings and experiences we have accumulated over many years.

The manufacturer is not liable for damage resulting from:

- Non-observance of the operating instructions
- Improper use
- Use by untrained personnel
- Unauthorized modifications
- Technical changes
- Use of unauthorized replacement parts and accessories

The actual scope of delivery may differ from the explanations and illustrations described, in case of special designs, if additional order options are utilized, or due to the latest technical changes.

The obligations agreed upon in the delivery contract and our General Terms and Conditions apply, as well as the delivery conditions of the manufacturer and all regulations applicable at the time the contract was concluded.

We reserve the right to make technical changes within the scope of improving useful properties and further development.

1.3 Copyright

These operating instructions are protected by copyright and exclusively intended for customer-internal purposes.

Provision of the operating instructions to third parties, duplications of any kind - also in extracts - as well as utilization and/or communication of the contents are not permitted without written approval of the manufacturer except for customer-internal purposes.

Violations will be subject to damages. Further claims remain reserved.

Sliding Contact Sensor Unit

Program 0811

1.4 Spare Parts



WARNING!

Safety risk due to wrong spare parts!

Wrong or faulty spare parts can impair safety and result in damage, malfunction or complete failure.

→ Only use original spare parts of the manufacturer!

Purchase spare parts from authorized dealers or directly from the manufacturer.

Conductix-Wampfler GmbH
Rheinstrasse 27 + 33
79576 Weil am Rhein - Maerkt
Germany

Phone: +49 (0) 7621 662-0
Fax: +49 (0) 7621 662-144
info.de@conductix.com
www.conductix.com

1.5 Material Defects

The regulations on material defects are listed in the General Terms and Conditions.

1.6 Technical Support

Our customer support staff will be available for technical support.

Conductix-Wampfler GmbH
Rheinstrasse 27 + 33
79576 Weil am Rhein - Maerkt
Germany

Phone: +49 (0) 7621 662-0
Fax: +49 (0) 7621 662-144
info.de@conductix.com
www.conductix.com

Moreover, our employees are constantly interested in new information and experience resulting from the application, which might be valuable for the improvement of our products.

2 Safety Instructions

2.1 Explication of Symbols

Safety advice in these operating instructions is marked by symbols. Safety instructions are initiated by signal words to indicate the degree of hazard. Always observe safety instructions and act carefully to avoid accidents, personal injury, or property damage!



DANGER!

indicates an immediately hazardous situation, which if not avoided, may result in death or serious injury.

Sliding Contact Sensor Unit

Program 0811



DANGER!

... indicates an immediately hazardous situation due to electricity, which if not avoided, may result in death or serious injury.



WARNING!

indicates a possibly dangerous situation, which may cause deadly accidents or serious injuries, if not avoided.



DANGER!

indicates a possibly hazardous situation due to electricity, which if not avoided, may result in death or serious injury.



CAUTION!

indicates a possibly dangerous situation, which, if not avoided, may result in moderate or minor injury or property damage.



Advice and recommendations:

... refers to useful advice and recommendations as well as information for an efficient and trouble-free operation.



CAUTION!

...refers to measures that will help you avoid property damage.

Sliding Contact Sensor Unit

Program 0811

2.2 Requirements to the Personnel

2.2.1 Qualification



WARNING!

Risk of injury due to insufficient qualification!

Improper use can result in serious injury to people and property damage.

→ All activities may only be performed by qualified personnel.

The following qualifications have been mentioned in these operating instructions for different fields of operation:

■ **Trained personnel/operators**

have been instructed in an instruction session by the operator with respect to the tasks assigned to them and the potential dangers arising from improper actions.

■ **Qualified specialists**

due to their specialized training, knowledge, and experience, as well as knowledge of applicable regulations, can carry out works assigned to them, while independently recognizing and avoiding possible risks.

■ Only those persons are authorized as personnel who can be expected to perform their work reliably. People whose responsiveness is influenced e.g., by drugs, alcohol, or medications, for example, are not permitted.

■ When selecting personnel, all age- and occupation-specific regulations applicable at the place of installation must be observed.

2.2.2 Unauthorized Personnel



WARNING!

Danger due to unauthorized personnel!

Unauthorized personnel who do not meet the requirements described here do not understand the dangers in the working area.

→ Keep unauthorized personnel away from the working area.

→ In case of doubt, address the persons and direct them away from the working area.

→ Stop work as long as unauthorized personnel is in the working area.

2.2.3 Instruction

Before commissioning the equipment, the personnel must be instructed by the operator. For a better tracking, record the implementation of the instruction as follows:

Date	Name	Type of instruction	Instruction given by	Signature
05.11.2009	Heinz Mustermann	First safety instruction for the personnel	Horst Miller	

Fig. 1: Example of an instruction protocol

Sliding Contact Sensor Unit

Program 0811

2.3 Personal Protective Equipment

Basically wear: For all work, always wear:



Work safety clothing

Primarily as a protection against entrapment by moving machine parts. Work clothes must be tightly-fitting with low tear resistance, close-fitting sleeves, and no protruding parts.



Protective footwear

As a protection against falling heavy parts and slipping on slippery floors.

For special tasks, wear:

When carrying out particular tasks, special safety gear is required. These are referred to separately in the individual chapters.



Protective gloves

For the protection of hands from friction, scrapes, stab wounds or deep injuries, as well as from contact with hot surfaces.



Protective headgear

For protection from falling and flying parts and materials.



Safety goggles

To protect the eyes from harmful influences such as strong light, chemicals, dust, splinters, or weather conditions.



Respiratory mask (FFP-3 – according to country-specific requirements)

For protection against substances, particles or organisms. Here: Protection from dust caused by abrasion of sliding contacts and the PVC-insulation of the conductor rail.

Sliding Contact Sensor Unit

Program 0811

2.4 Intended Use

The equipment is exclusively designed and built for the intended use described here.

Recommended use:

- Sliding contact sensor units are used for the monitoring of the sliding contacts in electrified monorail systems (EMS). For this purpose, a sliding contact sensor unit is installed in the conductor rail, which is installed in the support profile of the EMS.
- By means of the sensors in the sliding contact sensor unit and the corresponding program adaptations to be made by the operator, the control unit of the EMS can detect missing sliding contacts or sliding contacts worn beyond the wear limit and issue a corresponding error message.
- Software or supplements to the program code of the EMS control are not included in the scope of delivery!



WARNING!

Danger due to improper use!

Any application that deviates from and/or goes beyond the intended use of the device can result in a hazardous situation.

- Use the device only as intended.
- All details of these operating instructions must be strictly observed.
- Do not use the unit for purposes other than those for which it is intended!

In particular, the following are considered as non-intended use:

- Using the device with unapproved accessories not authorized by the manufacturer
- Operation of the device by untrained personnel
- Operation of the device outdoors
- Operation of the device when installed on an improper foundation / base.

Claims of any kind due to damage from improper use are excluded.

The operator is liable for all damage resulting from unintended use.

It is essential to observe these technical conditions during the installation:

- Installation position in the rail according to the drawing in the project documentation
- Installation height at the same level as the conductor rail level
- Suitable installation site with reduced speed

Electrotechnical operating conditions:

- The electrical system must be secured in accordance with the regulations applicable on site.

2.5 Protective Measures by the Operator / User

The equipment is used in the industrial sector (electrified monorail systems). The operator of the device is therefore subject to the legal obligations for occupational safety. In addition to the safety instructions in these operating instructions, all safety, accident

Sliding Contact Sensor Unit

Program 0811

protection, and environmental regulations applicable at the place of operation of the device must also be observed. This particularly includes:

- Work on electrical components of the system may **only be carried out when the system is disconnected from the power**.
- The operator must be informed about the applicable health and safety regulations and identify any additional hazards that result from the special working conditions at the operation site of the device. These must be implemented in the form of operating instructions for the use of the device.
- During the entire operating time of the device the operator must check, if his operating instructions correspond to the current state of regulations, and adapt these instructions, if necessary.
- The operator must clearly regulate and determine responsibilities for installation, operation, troubleshooting, and maintenance.
- The operator must ensure that all employees involved in operating the device have read and understood these installation and operating instructions. He must furthermore train the personnel at regular intervals and inform them of hazards.
- The operator must provide the personnel with all required safety gear.

The operator is furthermore responsible for ensuring that the device is always in a technically trouble-free condition. The following thus applies:

- The operator must ensure that the maintenance intervals described in these operating instructions are observed.
- The operator must have all safety systems regularly inspected for proper functioning and completeness.
- If the device or system has been modified, the safety systems must be inspected again and adapted to the changed conditions in such a way that the device or system is safe again.

2.6 5 Safety Rules for Working on Electrical Equipment

- Work on electrical components of the system may only be carried out when disconnected from the power. Follow the **5 safety rules** (see DIN VDE 0150-100:2009-10 / EN 50110-1:2004-11) before starting the works:
 1. Disconnect the system from the power supply at the main switch
 2. Secure the main switch against being switched on again
 3. Ascertain the disconnection from the power supply by measuring
 4. Ground and short-circuit system parts to be processed
 5. Cover or block off neighboring parts still carrying electrical current.
- Only qualified electricians or persons trained in electrical engineering may disconnect the device from the power supply or allow its reconnection after works have been carried out in a de-energized state!



Sliding Contact Sensor Unit

Program 0811

2.7 Special Hazards

The following section lists residual risks determined on the basis of a risk assessment.

- Follow the here listed safety instructions and the warnings in the following chapters of these operating instructions to reduce health hazards and avoid dangerous situations.

2.7.1 Electrical Hazards and Sources of Danger

Danger of life due to electric shock!

Touching live components may result in death or serious injury from electric shock. There is also a risk of injury due to startle response, falling or being catapulted due to an electric shock.

Risk of injury from falling or being catapulted after an electric shock!

- Live parts: Conductor rail, power feed, current collector, devices and connections at the sliding contact sensor unit and inside switch cabinets, etc.

Prior to working on the parts listed above:

- Disconnect the **conductor rail system from the power supply** in accordance with the 5 safety rules **and secure it against being switched on again.**
5 safety rules see chapter 2.6



During the works:

- Use an insulated tool
- Observe the requirements for working on live components and systems.

Prior to switching-on!

- Prior to each start of the device or system test the insulation resistance according to the technical standards, directives, and laws applicable on site.
- Perform the prescribed electrical tests customary in the respective country

Maintain electrical safety:

- Regularly check and maintain the electrical equipment
- If dangerous defects are observed, inform the system operator immediately
- Always replace blown fuses by equivalent ones

Sliding Contact Sensor Unit

Program 0811

2.7.2 Mechanical Hazards and Sources of Danger

Risk of injury due to crushing!

There is a risk of crushing skin and limbs due to:

- Moving parts, e. g. suspensions in the suspended monorail
- Current collector (spring force) during assembly, disassembly and maintenance

Risk of injury due to impact!

- Keep a distance to moving or rolling units, block the work area if necessary.
- Installation to be carried out by trained specialists only
- Wear safety shoes, protective gloves and safety helmet when working on the conductor rail system
- Set up the ladder in such a way that it is not hit by suspensions (risk of falling).



2.7.3 Danger due to Dust and Vapors

Risk of sensitization, mucous membrane irritation and respiratory diseases due to dust!

Abrasion of carbon brushes is accumulated in the conductor rails and the support profile. This dust is very fine and is classified as harmful to health. Sensitization may occur with frequent handling. People who spend frequent and longer periods of time in a heavily frequented facility without protective equipment must expect these **consequences**:

- Mucous membrane irritation
- Respiratory diseases
- Cancer

These consequences must also be expected if dust accumulations are handled carelessly (e. g. blowing out the dust with compressed air).

- Wear personal protective equipment during all works on the conductor rail system where deposited dust is stirred up. Wear the personal protective equipment especially when cleaning
- Safety goggles
- Dust mask class FFP3
- Gloves
- Disposable overall
- Before starting work, clean the conductor rail as prescribed. There is a special maintenance regulation for this, see chapter 11.1. Protect the surroundings during cleaning work, e. g. by covering or removing stored goods and blocking off areas where dust could fall on people.
- Do **not blow out dust with compressed air** but suck it off. The vacuum cleaner should be equipped with a fine filter class H.
- Do not eat, drink or smoke during these works!



Sliding Contact Sensor Unit

Program 0811

2.8 Actions in the Event of Accidents and Disturbances

Measures in case of accidents:

- Take first aid measures.
- Rescue persons by taking them out of the danger zone.
- Inform the responsible person at the operation site.
- Alert the rescue service.
- Clear access routes for emergency vehicles.

Sliding Contact Sensor Unit

Program 0811

3 Technical Data

3.1 General Information

Order number of the sliding contact sensor unit	08-V015-0498	08-V015-0112
Poles	4	6
Dimensions H x B x T [mm]	78 x 83.1 x 11.2	118 x 83.1 x 11.2
Weight [kg]	0.25	0.3
Maximum speed	60m/min (1m/s)	60m/min (1m/s)

3.2 Electrical Interface

Data of the inductive sensor:

Order No.:	GE-IES200		
Manufacturer, type	IFM, IES200		
electrical			
	Design		
	Operating voltage sensors U_B	[V]	10 ... 30, DC
	Current consumption	[mA]	< 20
Outputs			
	Output function		Closing contact
	Voltage drop	[V]	2.5
	Current-carrying capacity	[mA]	100
	Switching frequency	[Hz]	2000
Recording zone			
	Switching distance	[mm]	3
	Real switching distance	[mm]	3 ±10%
Environment			
	Temperature range	[°C]	-40 ...+85
	Protection class		IP 65; IP 66; IP 67; IP 68; IP 69K; (with ifm socket screwed on as prescribed)
Connection			
	Wiring		3-wire-technology

Sliding Contact Sensor Unit Program 0811

Cable and plug:

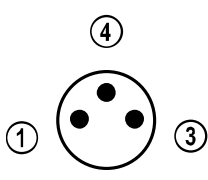
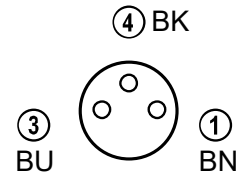
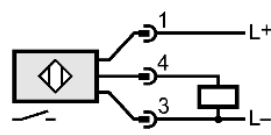
Code	Wire color	Function, standard at 3-wire-technology	Plug / cable socket	Pin assignment plug connection	
				Plug	Cable socket
BN	Brown	L+	Pin 1		
BU	Blue	L-	Pin 3		
BK	Black	Output	Pin 4		
					

3.3 Operating Conditions

Environment:

Designation	Value	Notes
Temperature range	-10 to + 55 °C	
Relative humidity, maximum	60 %	Application indoors only

Sliding Contact Sensor Unit

Program 0811

4 Product Description and Mode of Operation

4.1 Short Description

For the energy supply of EM-systems Conductix-Wampfler has developed the 0811 conductor rail system. A sliding contact sensor unit is optionally available for this system, which can be used to closely monitor the condition of the sliding contacts. The sliding contact sensor unit is integrated into the conductor rail and allows the check of the sliding contacts. On each transfer of the current collectors, the sliding contact sensor unit supplies a signal to the control system of the EM-system.

If the control of the EM-system is equipped accordingly, it can generate the following message from the signal of the sliding contact sensor unit and the position of the EM-system:

- Wear limit of one or more sliding contacts reached

4.2 Design and Mode of Operation of Inductive Sensors

Inductive sensors (proximity switches) contain a spool (6) and a condenser (4) that form an LC resonant circuit. The oscillating circuit can be used to generate an alternating magnetic field (7) in front of the sensor with a small amount of energy. If a conductive object is brought into the alternating magnetic field, an eddy current is generated in the conductive object. The eddy current extracts energy from the LC resonant circuit and thus dampens the oscillation to a greater or lesser extent (damping). Both states of the oscillating circuit "oscillating" or "not oscillating" are used by an additional switching to generate a binary output signal (current flowing = 1 = high / current not flowing = 0 = low).

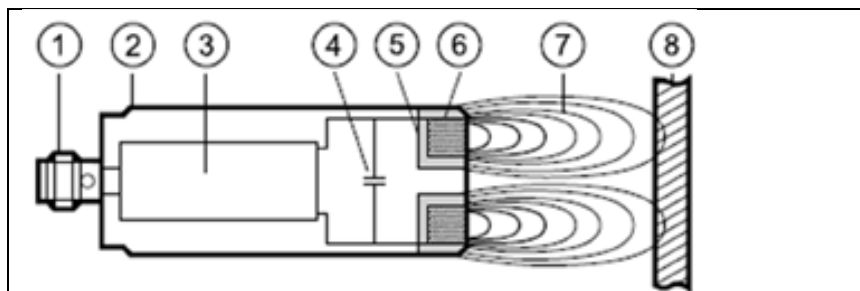

Fig. 1: Inductive sensor, schematic

(1) Connection	(5) Pot core
(2) Housing	(6) Spool
(3) Follow-up electronics	(7) Electromagnetic alternating field
(4) Condenser	(8) Switching flag (target) = electrically conductive material

Sliding Contact Sensor Unit

Program 0811

4.3 Function of the Sliding Contact Sensor Unit

The sliding contacts are tested by means of an inductive proximity switch (sensor). If the sliding contacts pass the sensor unit, a balancer is actuated if the sliding contact is worn out. At the switching output, the sensor provides the signal as a voltage level (balancer actuated = high / 1) so that it can be processed by the control (SPS) of the EM-system.

The inductive sensor is supplied with an operating voltage U_B of 10 to 30 V DC. This voltage is existing at the switching output (sliding contact not in order = 1 = high = U_B) if a non-functional sliding contact passes the sensor unit. Without damping (see chapter 4.2) the switching output remains at 0 V (sliding contacts in order).

The operating voltage U_B for the inductive sensor must be provided by the electrical installation at the installation site.

Operational case	Switching output	Comment
No current collector in the recording zone	Low / 0	
Sliding contact in the recording zone Condition: in order (i. o.)	Low / 0	Current collector existing and in order (i. o.)
Sliding contact in the recording zone, Condition: worn out	High / 1	Current collector existing, but not functional (sliding contact worn out)

Remark: "Recording zone" in the previous table means "recording zone of the sensor unit" (= distance on which the condition of the sliding contacts is checked), not "recording zone of the sensor", see table in chapter 3.2.

For the time during which the sliding contacts travel over the sensor, the switching output of the inductive sensor is set to "1". In case of double current collectors, this generates 2 impulses, so the condition of the double current collector can be checked.

Via the evaluation that a double impulse is existing, the evaluation for the condition of the double current collector can be performed. If a sliding contact of the current collector is worn out or broken off, the sensor outputs an impulse "1", it is however not obvious which sliding contact is faulty, it can also be the PE follower.

The pause between the sliding contact of the first current collector and the sliding contact of the PE follower depends on the distance between the two current collectors and their speed above the sliding contact sensor unit.

4.4 The Output Signal

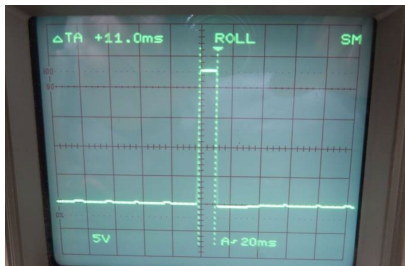

Fig. 2: Output signal of the sensor

Sliding Contact Sensor Unit

Program 0811

4.5 Prerequisite for Reliable Evaluation

In order to generate reproducible evaluation results, the sliding contacts must travel through the sensor unit at a uniform speed that is not too high.

Conductix-Wampfler therefore recommends integrating the sliding contact sensor unit into a section of the line in which the suspensions travel through the sensor unit at a low and uniform speed.

The speed is limited because the control (SPS) of the EM-system queries the status of the sensor time-discretely (= individual points in time, not continuously) and in cycles. The maximum speed therefore depends on the time interval between the status queries, the cycle time. If the sliding contacts travel through the sensor unit at a too high speed, it cannot be ensured that the sliding contacts are recorded correctly.

Here Conductix-Wampfler recommends that the people planning the EM-system coordinate at an early stage with those programming the control system. Together they can determine the speed of the suspensions and a reasonable cycle time of the control.

The contour evaluated by the sensor unit has a length of minimum 7 mm. As long as this contour passes through the sensor unit, the sensor is actuated. To ensure a reliable evaluation, it is recommended that at least 2 measurements are taken as long as the sensor is actuated.

Under these conditions, the following table results for the maximum cycle time of the entire system depending on the speed at the sensor:

Speed in m/min	Speed in m/s	For a track of 7 mm to be detected with 2 measurements on this track	Maximum cycle time (SPS, Feldbus etc.)
60.0 m/min	1.00 m/s		3.5 ms
40.0 m/min	0.67 m/s		5.3 ms
20.0 m/min	0.33 m/s		10.5 ms
10.0 m/min	0.17 m/s		21.0 ms
4.0 m/min	0.07 m/s		52.5 ms
2.0 m/min	0.03 m/s		105.0 ms

Practical value

The practical value is a speed at the measuring point of 3.5 m/min or lower, so that the sliding contacts can be detected reliably and standard SPS-assemblies can be used. Cycle times of less than 0.06 s (60 ms) are not possible with many SPS-systems since higher cycle times are the result when a SPS is optimally utilized.

Sliding Contact Sensor Unit

Program 0811

4.6 Possibilities for Impulse Extension

If it is not possible to reduce the speed for a given cycle time, the impulse duration can be artificially extended using external assemblies instead. If necessary, please contact Conductix-Wampler.

In practice, this can be neglected, if the test section is laid out in an area where the suspensions process-related travel at a low speed. Suitable areas can be found, for example, in front of lifters or when entering or leaving a buffer section.

4.7 Evaluation Logic

The logical evaluation of the signals generated by the sensor unit is the task of the system control software. Besides the status information from the sliding contact sensor unit, other information is incorporated into the algorithm depending on the system concept, such as:

- Vehicle or suspension ID,
- Current speed,
- Position.

A program example for a possible evaluation is documented in the appendix.

Sliding Contact Sensor Unit

Program 0811

5 Transport, Packaging and Storage

5.1 Transport

5.1.1 Transport Inspection

Check the shipment for completeness and transport damage immediately upon receipt.

If transport damage is externally visible, proceed as follows:

- Do not accept the shipment or accept it only with reservations.
- Note the scope of damage on the transport documents or on the transporter's delivery note.
- Initiate a complaint.



ATTENTION!

Claim any defect as soon as it has been detected. Compensation claims may only be made within the applicable complaint periods.

5.2 Packaging

The individual packages must be packed according to the transport conditions to be expected. Only environmentally friendly materials have been used for packaging.

The packaging must protect the individual components from transport damage, corrosion and other damage until the installation will be made. Thus, do not destroy the packaging and only remove it immediately before the installation.

Handling of packaging materials:

Dispose of packaging material according to the valid legal regulations and local guidelines.



CAUTION!

Environmental damage due to improper disposal!

Packaging material is a valuable resource and can be reused, processed or recycled in many cases.

- Dispose of packaging materials in an environmentally appropriate manner.
- Comply with locally applicable disposal guidelines; if necessary, engage a specialist for the
- disposal.

Sliding Contact Sensor Unit

Program 0811

5.3 Storage of the Packages

Store packages under the following conditions:

- Do not store outdoors.
- Store in a dry, dust-free place.
- Do not expose to aggressive media.
- Protect from direct solar radiation.
- Avoid mechanical vibrations.
- Storage temperature: -30 to + 40 °C
- Relative humidity: max. 60%.
- When storing for more than 3 months, check the general condition of all parts and the packaging at regular intervals. If necessary, add or replace the preservative.



Under some circumstances, there may be instructions for storage on the packages which go beyond the requirements listed here. Follow them appropriately.

ATTENTION!

Sliding Contact Sensor Unit

Program 0811

6 Assembly and Commissioning

6.1 Safety

Personnel:

- Installation and initial commissioning may only be carried out by specially trained technicians.

Wear the following protective gear during all work of installation and initial commissioning:



Work safety clothing



Protective helmet



Protective footwear



Protective gloves



DANGER!

Danger of life due to electric shock!

Touching live components may result in death or serious injury from electric shock. There is also a risk of injury due to startle response, falling or being catapulted due to an electric shock.

- Live parts: Conductor rail, power feed, current collector, devices and connections at the sliding contact sensor unit and inside switch cabinets, etc.

Prior to working on the parts listed above:

- Disconnect the **conductor rail system from the power supply** in accordance with the 5 safety rules and **secure it against being switched on again**. 5 safety rules see chapter 2.6



During the works:

- Use an insulated tool.
- Observe the requirements for working on live components and systems.

Prior to switching-on!

- Prior to each start of the device or system test the insulation resistance according to the technical standards, directives, and laws applicable on site.
- Perform the prescribed electrical tests customary in the respective country.

Maintain electrical safety:

- Regularly check and maintain the electrical equipment.
- If dangerous defects are observed, inform the system operator immediately.
- Always replace blown fuses by equivalent ones.



Danger to life due to suspended loads!

Falling loads can lead to severe injuries or death.

Sliding Contact Sensor Unit

Program 0811

WARNING!

- Never step under suspended loads.
- Move loads only under supervision.
- Set down loads before leaving the work area.



WARNING!

Risk of sensitization, mucous membrane irritation and respiratory diseases due to dust!

Abrasion of sliding contacts is accumulated in the conductor rails and the support profile. This dust is very fine and is classified as harmful to health. Sensitization may occur with frequent handling. People who spend frequent and longer periods of time in a heavily frequented facility without protective equipment must expect these **consequences**:

- Mucous membrane irritation
- Respiratory diseases
- Cancer

These consequences must also be expected if dust accumulations are handled carelessly (e. g. blowing out the dust with compressed air).

- At workplaces with continuous exposure and heavily frequented facilities, protect workers from the dust by effective measures.
 - Wear personal protective equipment for all works on the conductor rail system where deposited dust is stirred up. Wear the personal protective equipment especially when cleaning.
- Safety goggles
 - Dust mask class FFP3
 - Gloves
 - Disposable overall
- Before starting work, clean the conductor rail as prescribed. There is a special maintenance regulation for this, see chapter 11.1.
 - Protect the surroundings during cleaning work, e. g. by covering or removing stored goods and blocking off areas where dust could fall on people.
 - Do **not blow out dust with compressed air** but suck it off. The vacuum cleaner should be equipped with a fine filter class H.
 - Do not eat, drink or smoke during these works!



Sliding Contact Sensor Unit

Program 0811



WARNING!

Injury due to improper installation and initial commissioning!

Improper installation and initial commissioning can result in serious injury to persons and property.

- Before starting work, ensure sufficient space for assembly.
- Handle open, sharp-edges components carefully.
- Maintain order and cleanliness in the assembly area! Loosely stacked or scattered components and tools are a source of accidents.
- Mount components properly. Comply with specified screw tightening torques.
- Secure components so that they cannot fall or tip over.

6.2 Preparations

Necessary preliminary works:

The dimensions of the **hole for the sensor and the fixing holes** are listed in chapter 6.3.1 in Fig. 5. It is recommended to create a drawing in advance, which can be provided for example in the context of a **project documentation**.

- Disconnect the conductor rail from the power supply, observe the safety instructions and warnings!
- Drill a suitable hole for the sensor (Ø18 mm) in the support profile!
- Drill mounting holes!

Required tool:

- Flat wrench SW 8
- Allen wrench 3 mm
- Key file
- Metering rule
- Pencil / scriber / felt-tip pen

Sliding Contact Sensor Unit

Program 0811

6.3 Assembly



WARNING!

Danger of falling on uneven or slippery ground!

When falling from the ladder, there is a risk of serious to life-threatening injuries.

- Use load-bearing and stable ladders.
- Ensure that the ladder has a safe standing. If necessary, clean the ground or use a suitable base.
- Remove any EMS-vehicles located in the work area, block the work area.
- Set up the ladder so that it is not hit by suspensions.



WARNING!

Danger of crushing!

There is a risk of crushing skin and limbs due to:

- moving parts, e. g. suspensions in the overhead monorail
- Current collector (spring force) during assembly, disassembly and maintenance

- Keep a distance to moving or rolling units, block the work area if necessary.
- Installation to be carried out by trained specialists only
- Wear safety shoes, protective gloves and safety helmet when working on the conductor rail system.

Personnel:

- Execution by experienced electricians only

Sliding Contact Sensor Unit Program 0811

6.3.1 Installation of the Sliding Contact Sensor Unit

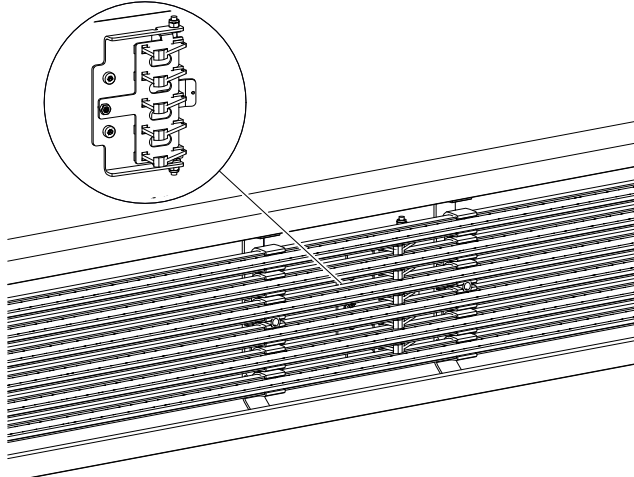

Fig. 3: Conductor rail section with sliding contact sensor unit Program 0811

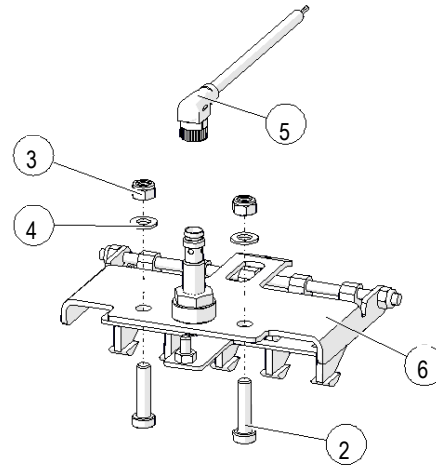

Fig. 4: Sliding contact sensor unit program 0811

Item	Designation
2	Head cap screw DIN7984-M05X020-8.8-GA
3	Lock nut DIN985-M4-A2
4	Washer DIN125-A5.3-GA
5	Connecting cable M8X1 3 pole
6	Sliding contact sensor unit

- The sliding contact sensor unit is installed in the center web of the support profile.
- The **fixing holes** shall be made according to a drawing provided in the context of the project as **project documentation**. The **figures in this document are only examples!**
- The sliding contact sensor unit is mounted on the side where the conductor rail is located. Relining is therefore not required for different web widths.

Example:

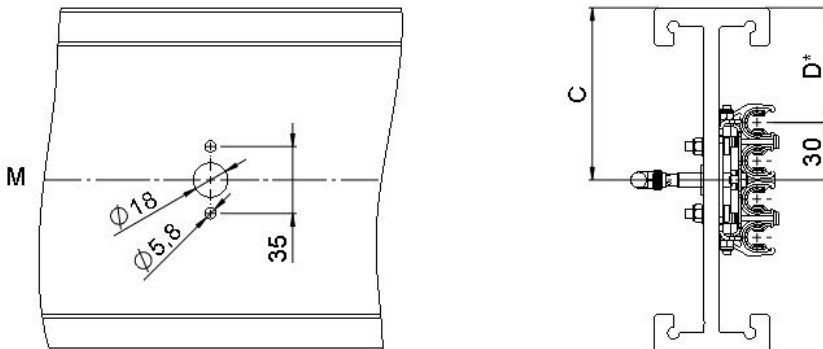

Fig. 5: Example: Bore hole pattern sliding contact sensor unit (4-poles)

Sliding Contact Sensor Unit

Program 0811

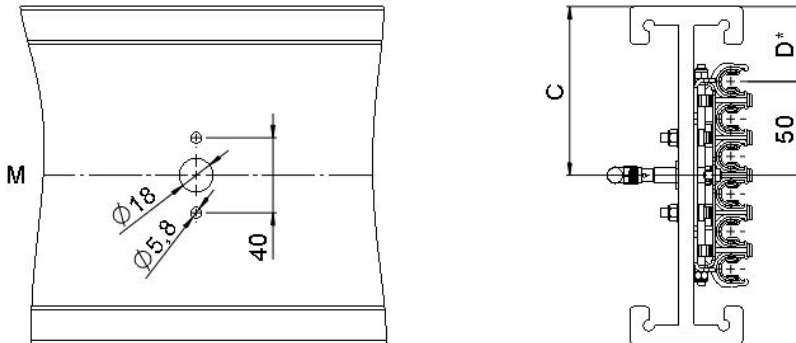

Fig. 6: Example: Bore hole pattern sliding contact sensor unit (6-poles)

M = Conductor rail center

*Distance from the top edge of the EMS profile to the center of the first conductor rail pole. The position of the conductor rail (dimension D) is an individual system dimension and must be determined on site.

Sliding contact sensor unit (number of poles)	Drilling distance	Determination of dimension „C“
4-pole	35 mm	$C = D^* + 30 \text{ mm}$
6-pole	40 mm	$C = D^* + 50 \text{ mm}$

Remark

The position of the holes depends on the center of all conductor rails (example: with 6 poles, the conductor rail center M lies between the 3rd and 4th pole see Fig. 6). In this example, the 6 poles were placed in the center of the EMS-profile.

Sliding Contact Sensor Unit Program 0811

Assembly steps (mechanical integration)



Do not adjust the sensor distance any longer!

The sensors are factory-set to the sliding contact type used and therefore no longer need to be adjusted on site.

- Drill holes for fixing screws (\varnothing 5.8 mm) and holes for tube (\varnothing 18 mm) into the EMS-profile (see Fig. 5 and Fig. 6). The drilling distance depends on the number of poles (4-pole or 6-pole). The center of the conductor rail M is an individual system dimension.
- Mount the hanger clamps, which are located to the right and left of the sliding contact sensor unit, at a distance of 100 mm from the sliding contact sensor unit (see Fig. 7).
- Screw the sliding contact sensor unit to the EMS-profile using head cap screw DIN7984 - M5x20 (item 2), washer DIN 125 (item 4) and lock nut DIN985 (item 3) (see Fig. 8).
- Slide the conductor rails laterally into the sliding contact sensor unit and hanger clamp (see Fig. 9).
- Attach the connecting cable (item 5) to the inductive sensor (item 7) (see Fig. 10). The socket of the connecting cable can be rotated to the desired position in 15°-steps.

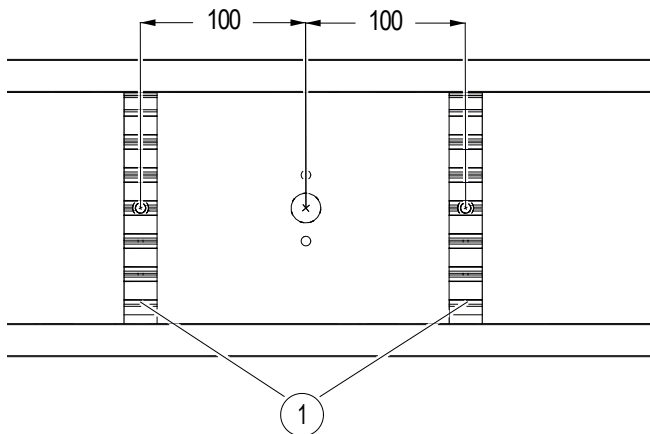

Fig. 7: Distance between hanger clamp and the sliding contact sensor unit

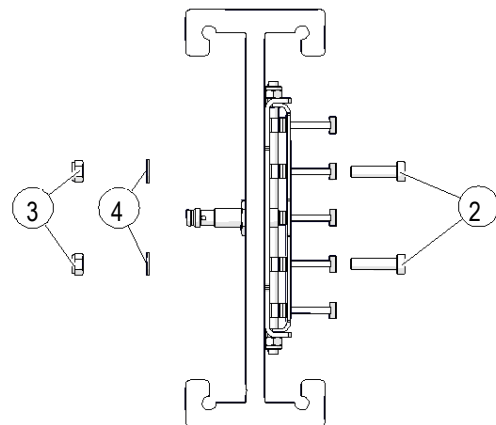

Fig. 8: Mount the sliding contact sensor unit

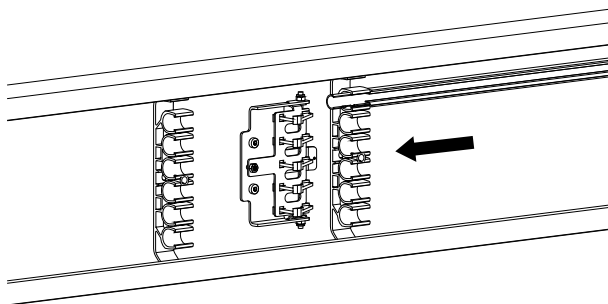

Fig. 9: Slide conductor rail laterally into the hanger clamp and sliding contact sensor unit

Sliding Contact Sensor Unit

Program 0811

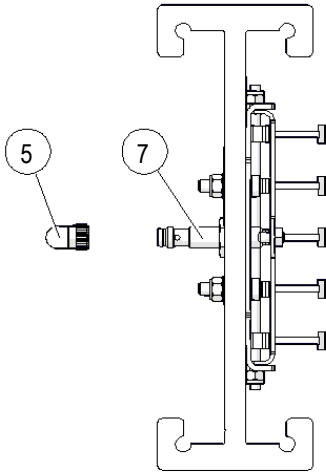

Fig. 10: Mount connecting cable

Check mechanical integration

→ Using a loose current collector, move the sliding contacts manually through the sliding contact sensor unit.

The assembly is perfect if the current collector does not get stuck and can be moved unhindered through the sliding contact sensor unit with uniform pressure.

6.3.2 Electrical Connection

Cable and plug

The sensor is supplied with 3-pole cable equipped with plug. Information on the pin assignment of the plug can be found in chap. 3.2, cable and plug.

Wire sensor individually in 3-wire technology

The inductive sensor must be wired individually to the control unit in 3-wire technology. Do not connect the sensors in series with other sensors or in 2-wire technology, otherwise errors may occur due to transition effects.

Sliding Contact Sensor Unit
Program 0811

6.4 Testing and Initial Commissioning



WARNING!

Danger of injury due to improper commissioning!

Improper commissioning can lead to dangerous situations for the personnel.

→ Prior to commissioning, carry out the tests according to the test list of the manufacturer.

6.4.1 Test List for Initial Commissioning

Activity	Checked
Check function of the sensor	
Check function of the evaluation	
Tighten all screws according to torque	
Type plate attached in a clearly legible manner	
Accessories (etc.) installed by technical personnel according to product documentation	
Operating personnel trained	

.....
Date

.....
Signature

6.4.2 Perform Initial Commissioning

To carry out initial commissioning: (Disconnect the conductor rail from the power supply! Observe safety instructions in chapter 2.7!)

1. Connect sliding contact sensor unit with the control of the EM-system / evaluation
2. Put software into operation
3. Pass through each pole of the sliding contact sensor unit with a faultless current collector with new sliding contact (good pattern) and a current collector with a worn sliding contact (bad pattern). Check if the control outputs a correct result (check all balancers one after the other).
4. Check suspensions with faultless sliding contacts and current collector unit in test mode and push manually over the sliding contact sensor unit => No error must be displayed
5. Test error display: Remove current collector and move the suspension manually over the sliding contact sensor unit => error must be detected
6. Repeat the procedure in step 3 for the additional PE current collector. Check if the control outputs a correct result.

Sliding Contact Sensor Unit

Program 0811

7 Operation

If the sliding contact sensor unit is mounted and properly commissioned, no further operating steps are required on the sliding contact sensor unit to fulfill the intended use.

→ Observe the maintenance instructions in chapter 2.8, to keep the operation as trouble-free as possible.

7.1 Safety



WARNING!

Danger for unauthorized personnel!

Unauthorized personnel who do not meet the requirements described in chapter 2.2 do not understand the dangers in the working area.

- Keep unauthorized personnel away from the working area.
- In case of doubt, address the persons and direct them away from the working area.
- Stop work as long as unauthorized personnel is in the working area.



DANGER!

Danger of life due to electric shock!

Live parts: Conductor rail, power feed, current collector, devices and connections at the sliding contact sensor unit and inside switch cabinets, etc.

Prior to working on the parts listed above:

- Disconnect the **conductor rail system from the power supply** in accordance with the 5 safety rules **and secure it against being switched on again**. 5 safety rules see chapter 2.6



Sliding Contact Sensor Unit

Program 0811

8 Maintenance and Servicing

8.1 Safety



WARNING!

Danger of injury due to improperly executed maintenance tasks!

Improper maintenance can result in serious injury and property damage.

- Before starting work, ensure sufficient space for assembly.
- Maintain order and cleanliness in the assembly area! Loosely stacked or scattered components and tools are a source of accidents.
- If components have been removed, be careful to reinstall them properly, replace all fastening elements, and comply with screw tightening torques.



DANGER!

Danger of life due to electric shock!

Live parts: Conductor rail, power feed, current collector, devices and connections at the sliding contact sensor unit and inside switch cabinets, etc.

Prior to working on the parts listed above:

- Disconnect the **conductor rail system from the power supply** in accordance with the 5 safety rules **and secure it against being switched on again**. 5 safety rules see chapter 2.6



WARNING!

Risk of sensitization, mucous membrane irritation and respiratory diseases due to dust!

Abrasion (dust) is accumulated in the conductor rails and the support profile which is harmful to health. For further information see chapter 2.7.3. Possible **consequences**:

- Mucous membrane irritation
- Respiratory diseases
- Cancer
- Do **not blow out dust with compressed air** but suck it off. The vacuum cleaner should be equipped with a fine filter class H.
- Wear personal protective equipment for all works on the conductor rail system where deposited dust is stirred up. Wear the personal protective equipment especially when cleaning:
 - Safety goggles
 - Dust mask class FFP3
 - Protective gloves
 - Disposable overall
- Before starting work, clean the conductor rail as prescribed. There is a special maintenance regulation for this, see chapter 11.1.
- Protect the surroundings during cleaning work, e. g. by covering or removing stored goods and blocking off areas where dust could fall down on people.
- Do not eat, drink or smoke during these works!



Sliding Contact Sensor Unit

Program 0811

8.2 Maintenance Schedule

The next sections describe the maintenance tasks required for optimum, trouble-free operation. The tasks carried out according to the maintenance schedule must be recorded.

If regular inspections reveal increased wear, the corresponding maintenance intervals should be shortened in accordance with the actual signs of wear.

In case of any questions regarding maintenance tasks and intervals, contact the manufacturer, see service address on the last page.

Interval	Maintenance work	To be carried out by
4 weeks after commissioning	Visual and functional inspection	Qualified electrician
All 6 months	Visual and functional inspection <ul style="list-style-type: none"> ■ Function test with good and bad pattern ■ Visual inspection for wear and damage 	Qualified electrician
	Check screwed connections <ul style="list-style-type: none"> ■ Check for tight fit of the screws ■ If necessary, tighten with torque (see chapter 6 „Assembly and commissioning“) 	Qualified electrician

Sliding Contact Sensor Unit

Program 0811

9 Fault Diagnosis



WARNING!

Danger of injury due to improper fault elimination!

Improper fault elimination can result in serious injury and property damage.

- Contact the manufacturer in case of malfunction.
- Allow troubleshooting to be carried out only by personnel from or authorized by the manufacturer.



DANGER!

Danger of life due to electric shock!

Live parts: Conductor rail, power feed, current collector, devices and connections at the sliding contact sensor unit and inside switch cabinets, etc.

Prior to working on the parts listed above:

- Disconnect the **conductor rail system from the power supply** in accordance with the 5 safety rules **and secure it against being switched on again**. 5 safety rules see chapter 2.6



WARNING!

Risk of sensitization, mucous membrane irritation and respiratory diseases due to dust!

Abrasion (dust) is accumulated in the conductor rails and the support profile which is harmful to health. For further information see chapter 2.7.3. Possible **consequences**:

- Mucous membrane irritation
 - Respiratory diseases
 - Cancer
- Do **not blow out dust with compressed air** but suck it off. The vacuum cleaner should be equipped with a fine filter class H.
 - Wear personal protective equipment for all works on the conductor rail system where deposited dust is stirred up. Wear the personal protective equipment especially when cleaning
 - Safety goggles
 - Dust mask class FFP3
 - Gloves
 - Disposable overall
 - Before starting work, clean the conductor rail as prescribed. There is a special maintenance regulation for this, see chapter 11.1.
 - Protect the surroundings during cleaning work, e. g. by covering or removing stored goods and blocking off areas where dust could fall on people.
 - Do not eat, drink or smoke during these works!



Sliding Contact Sensor Unit

Program 0811

Observation	Possible cause	Remedy
Sliding contact sensor unit contaminated with sliding contact dust	Not cleaned	Cleaning Observe maintenance instructions for cleaning of conductor rails, see chapter 11.1
Worn out sliding contacts receive good-signal	Sliding contact sensor unit worn out	Replace sliding contact sensor unit
Output of the signal not reliable	Loose contact in the sensor / the cable	Replace sensor / cable
No signal in case of bad sliding contact	Sensor defective / cable defective	Replace sensor / cable
No output / no effect of the signal	Control / evaluation faulty	Check control / evaluation

Sliding Contact Sensor Unit

Program 0811

10 Disassembly and Disposal

10.1 Safety



Danger of injury due to improper disassembly!

Stored residual energies, sharp components, points, and edges on and in the device or the required tools can cause injury.

- Before starting work, ensure sufficient space.
- Handle open, sharp-edges components carefully.
- Maintain order and cleanliness in the work area! Loosely stacked or scattered components and tools are sources of danger.
- Dismount components properly. Note the high dead weight of some components. If necessary, use lifting gear.
- Secure components so that they cannot fall or tip over.
- Involve the manufacturer in case of any unclear points.



Risk of sensitization, mucous membrane irritation and respiratory diseases due to dust!

Abrasion (dust) is accumulated in the conductor rails and the support profile which is harmful to health. For further information see chapter 2.7.3. Possible **consequences**:

- Mucous membrane irritation
 - Respiratory diseases
 - Cancer
-
- Do **not blow out dust with compressed air** but suck it off. The vacuum cleaner should be equipped with a fine filter class H.
 - Wear personal protective equipment for all works on the conductor rail system where deposited dust is stirred up. Wear the personal protective equipment especially when cleaning:
 - Safety goggles
 - Dust mask class FFP3
 - Gloves
 - Disposable overall
 - Before starting work, clean the conductor rail as prescribed. There is a special maintenance instruction for this, see chapter 11.1.
 - Protect the surroundings during cleaning work, e. g. by covering or removing stored goods and blocking off areas where dust could fall down on people.
 - Do not eat, drink or smoke during these works!



Sliding Contact Sensor Unit

Program 0811



DANGER!

Danger of life due to electric shock!

Live parts: Conductor rail, power feed, current collector, devices and connections at the sliding contact sensor unit and inside switch cabinets, etc.

Prior to working on the parts listed above:

→ Disconnect the **conductor rail system from the power supply** in accordance with the 5 safety rules **and secure it against being switched on again**. 5 safety rules see chapter 2.6.



10.2 Disassembly

After the system is no longer in use, the device must be disassembled and disposed of in an environmentally appropriate manner.

10.2.1 Dismounting the Assembly

Personnel:

- Execution by experienced electricians only

Required tool:

- See chapter 6.2
- Securing tool

10.3 Disposal

Properly disassembled components are to be recycled if no return or disposal agreement has been made.

- Scrap metals.
- Take plastic elements to recycling.
- The other components are to be disposed of according to their material composition.



CAUTION!

Environmental damage due to improper disposal!

Electrical waste, electronic components, lubricants and other auxiliary materials are subject to hazardous waste disposal regulations and may only be disposed of by authorized specialists.

Local community officials or special disposal companies can provide information about environmentally appropriate disposal.

Sliding Contact Sensor Unit

Program 0811

11 Additional Documents

11.1 Applicable Documents

Con-secu-tive No.	Document number	Name of the document
01	WV0800-0001	Cleaning of conductor rails

12 Index

Accidents	14	Material Defects	6
Assembly and Commissioning	23	Mode of Operation	17
Commissioning.....	31	Operating Conditions	16
Copyright.....	5	Operator	10
Disassembly	38	Packaging	21
Disposal.....	38	Personnel.....	8
Disturbances	14	Product Description.....	17
Explication of Symbols	6	Protective Measures	10
Fault Diagnosis.....	35	Safety.....	23, 32, 33, 37
Hazards	12	Spare Parts	6
Instruction	8	Storage.....	22
Intended use.....	10	Technical Data	15
Limitation of Liability	5	Technical Support	6
Maintenance and Servicing.....	33	Transport.....	21
Maintenance Schedule.....	34	Unauthorized Personnel.....	8

Operating instructions



Sliding contact sensor unit

Program 0811

13 Appendix Program Example (Contact Diagram)

Section 1 to 9: Evaluation of a sliding contact and the additional PE current collector

From section 10: I/O and flag listing

LADDER DIAGRAM:

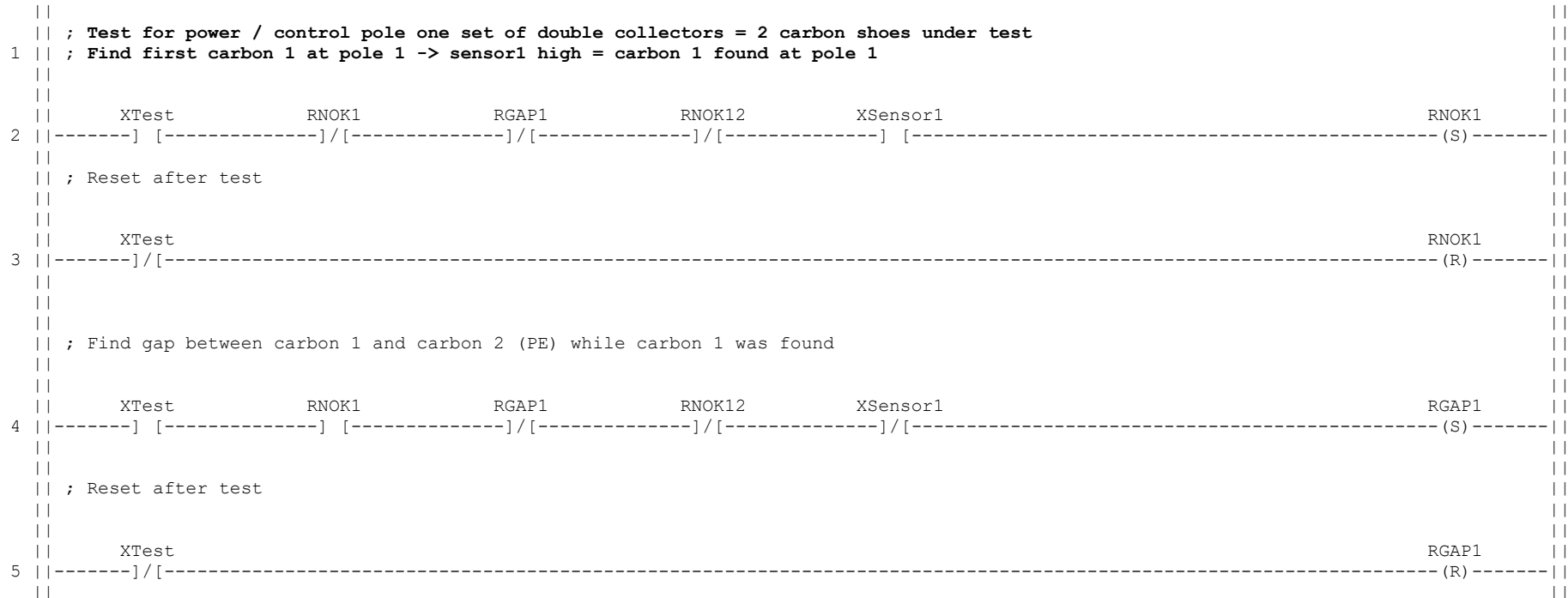

Operating instructions

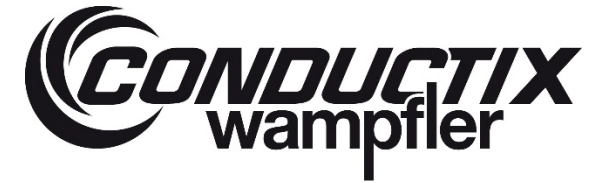

Sliding contact sensor unit

Program 0811

```
|| ; Find second carbon 2 (PE) -> sensor1 high = carbon 2 found (PE) ||
|| ; Carbon 1 and gap were found before ||
||
6 || XTest RNOk1 RGAP1 RNOk12 XSensor1 RNOk12 ||
|| -----] [-----] [-----] [-----]/[-----] [-----] (S) ----- ||
|| ; Reset after test ||
||
7 || XTest RNOk12 ||
|| -----]/[-----] (R) ----- ||
|| ; Both carbons and gap found - current collector at pole 1 ok ||
||
8 || XTest RNOk1 RGAP1 RNOk12 XSensor1 NOTREADY1 ||
|| -----[ ]-----] [-----] [-----]/[-----]/[-----] (S) ----- ||
||
9 || XTest RNOk1 RGAP1 RNOk12 XSensor1 NOTREADY12 ||
|| -----[ ]-----] [-----] [-----] [-----]/[-----] (S) ----- ||
|| ; Collector unit test passed ||
||
10 || XTest NOTREADY1 NOTREADY12 XSensor1 YTESTPASSED ||
|| -----(N)-----]/[-----]/[-----]/[-----] ( ) ----- ||
||
11 || XTest NOTREADY1 ||
|| -----]/[-----] (R) ----- ||
||
12 || XTest NOTREADY12 ||
|| -----]/[-----] (R) ----- ||
```

Operating instructions

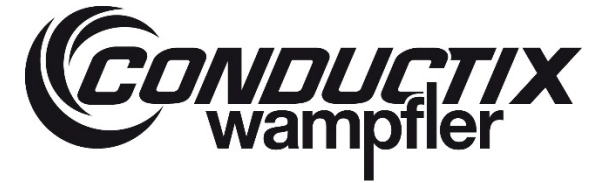

Sliding contact sensor unit

Program 0811

||
||-----[END]-----||
||

I/O ASSIGNMENT:

Name	Type	Pin
XSensor1	digital in	
XTest	digital in	
YTESTPASSED	digital out	
RGAP1	int. relay	
RNOK1	int. relay	
RNOK12	int. relay	
NOTREADY1	int. relay	
NOTREADY12	int. relay	

Operating instructions



Sliding contact sensor unit

Program 0811

Conductix-Wampfler GmbH
Rheinstraße 27 + 33
79576 Weil am Rhein - Märkt
Germany

Phone: +49 (0) 7621 662-0
Fax: +49 (0) 7621 662-144
info.de@conductix.com
www.conductix.com



Importer for the United Kingdom:
Conductix-Wampfler Ltd.
1, Michigan Avenue
Salford
M50 2GY
United Kingdom

Phone: +44 161 8480161
Fax: +44 161 8737017
info.uk@conductix.com
www.conductix.com