

# Spring Cable Reel Manual

## 1900/2400 Series PowerReel

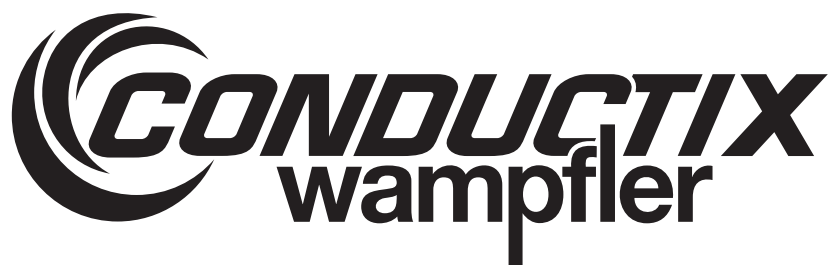
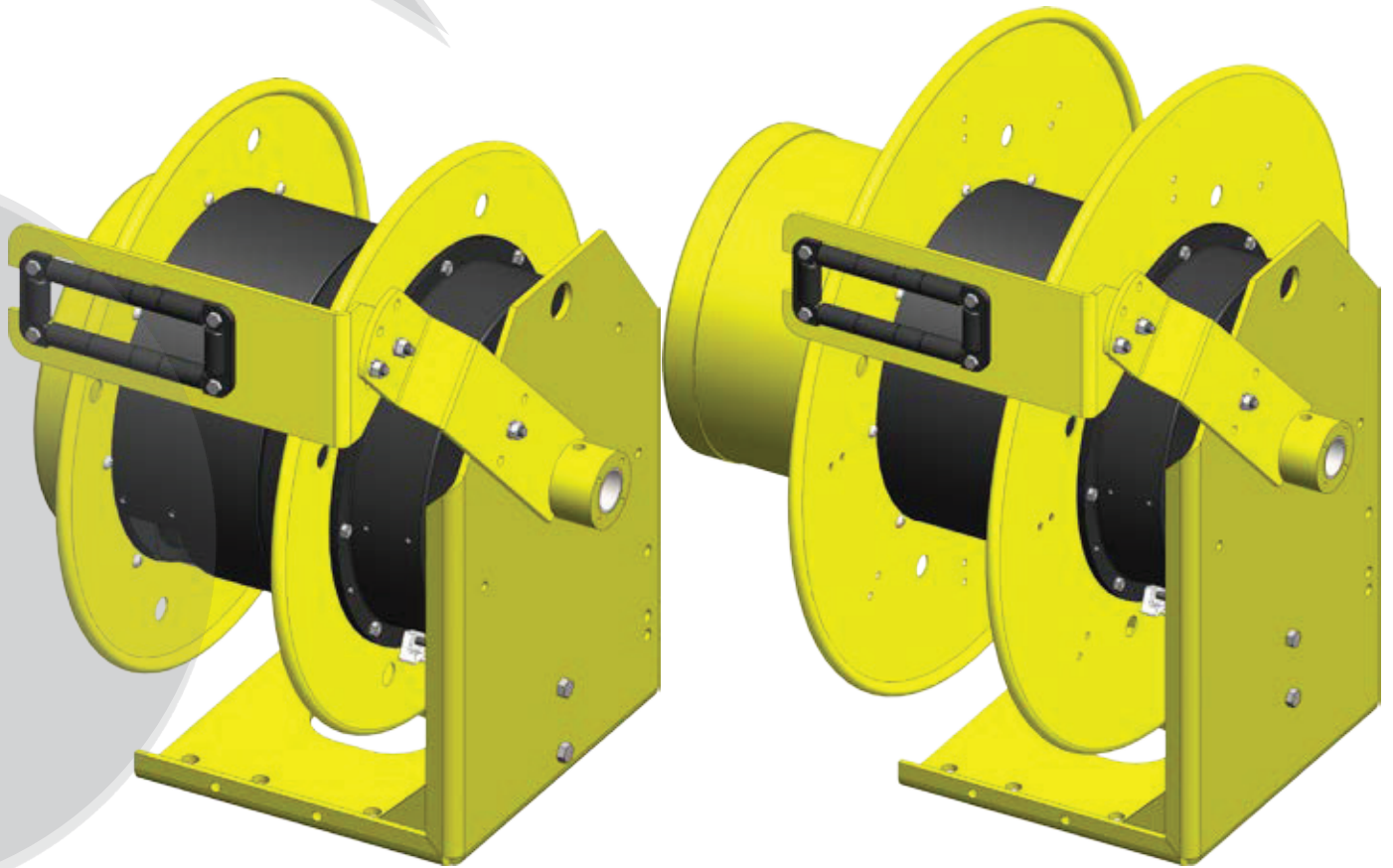

# CONDUCTIX INCORPORATED

The technical data and images which appear in this manual are for informational purposes only. NO WARRANTIES, EXPRESS OR IMPLIED, INCLUDING WARRANTIES OF MERCHANTABILITY OR FITNESS FOR A PARTICULAR PURPOSE, ARE CREATED BY THE DESCRIPTIONS AND DEPICTIONS OF THE PRODUCTS SHOWN IN THIS MANUAL. Conductix Inc. makes no warranty (and assumes no liability) as to function of equipment or operation of systems built according to customer design or of the ability of any of its products to interface, operate or function with any portions of customer systems not provided by Conductix Inc.

Seller agrees to repair or exchange the goods sold hereunder necessitated by reason of defective workmanship and material discovered and reported to Seller within one year after shipment of such goods to Buyer.

Except where the nature of the defect is such that it is appropriate, in Seller's judgment, to effect repairs on site, Seller's obligation hereunder to remedy defects shall be limited to repairing or replacing (at Seller's option) FOB point of original shipment by Seller, any part returned to Seller at the risk and cost of Buyer. Defective parts replaced by Seller shall become the property of Seller.

Seller shall only be obligated to make such repair or replacement if the goods have been used by Buyer only in service recommended by Seller and altered only as authorized by Seller. Seller is not responsible for defects which arise from improper installation, neglect, or improper use or from normal wear and tear.

Additionally, Seller's obligation shall be limited by the manufacturer's warranty (and is not further warranted by Seller) for all parts procured from others according to published data, specifications or performance information not designed by or for Seller.

Seller further agrees to replace or at Seller's option to provide a refund of the sales price of any goods that do not conform to applicable specifications or which differ from that agreed to be supplied which non-conformity is discovered and forthwith reported to Seller within thirty (30) days after shipment to the Buyer. Seller's obligation to replace or refund the purchase price for non-conforming goods shall arise once Buyer returns such goods FOB point of original shipment by Seller at the risk and cost of Buyer. Goods replaced by Seller shall become the property of Seller.

There is no guarantee or warranty as to anything made or sold by Seller, or any services performed, except as to title and freedom from encumbrances and, except as herein expressly stated and particularly, and without limiting the foregoing, there is no guarantee or warranty, express or implied, of merchantability or of fitness for any particular purpose or against claim of infringement or the like.

Seller makes no warranty (and assumes no liability) as to function of equipment or operation of systems built to Buyer's design or of the ability of any goods to interface, operate or function with any portions of Buyer's system not provided by Seller.

Seller's liability on any claim, whether in contract, tort (including negligence), or otherwise, for any loss or damage arising out of, connected with, or resulting from the manufacture, sale, delivery, resale, repair, replacement or use of any products or services shall in no case exceed the price paid for the product or services or any part thereof which give rise to the claim. In no event shall Seller be liable for consequential, special, incidental or other damages, nor shall Seller be liable in respect of personal injury or damage to property not the subject matter hereof unless attributable to gross misconduct of Seller, which shall mean an act or omission by Seller demonstrating reckless disregard of the foreseeable consequences thereof.

Seller is not responsible for incorrect choice of models or where products are used in excess of their rated and recommended capacities and design functions or under abnormal conditions. Seller assumes no liability for loss of time, damage or injuries to property or persons resulting from the use of Seller's products. Buyer shall hold Seller harmless from all liability, claims, suits and expenses in connection with loss or damage resulting from operation of products or utilization of services, respectively, of Seller and shall defend any suit or action which might arise there from in Buyer's name - provided that Seller shall have the right to elect to defend any such suit or action for the account of Buyer. The foregoing shall be the exclusive remedies of the Buyer and all persons and entities claiming through the Buyer.

### Need Field Service for our products? We Can Handle It!

Ask us for a quote on expert system installations, inspections, preventative maintenance, and repairs/retrofits.

As the world's largest single source manufacturer of mobile electrification products, Conductix-Wampfler has the unique ability to offer a degree of service not found anywhere else. Conductix-Wampfler's team of highly qualified service technicians and engineers have years of experience servicing our complete line of products.

We can provide:

- **Annual Service contracts**
- **Installation**
- **Commissioning**
- **Installation supervision** to ensure your installers avoid common mistakes.
- **Troubleshooting** to get you up and running.
- **Pre-planned inspections** to complement your preventive maintenance program.

Call 1-800-521-4888 for further details.



# TABLE OF CONTENTS

<b>SECTION 1 - SAFETY</b>	<b>6-9</b>
1.0 Safety Information Responsibility	6
1.1 Safety Messages	6
1.2 Limitation of Liability	6
1.3 Personnel Requirements-Qualifications	7
1.4 Personnel Requirements-Unauthorized Personnel	7
1.5 Personnel Requirements - Training	8
1.6 Personnel Protective Equipment	8
1.7 Electrical Warnings	8
1.8 Operational Warnings	8
1.9 Maintenance Warnings	9
<b>SECTION 2 - PRODUCT DISPOSAL</b>	<b>10</b>
2.0 Product Disposal & Recycling	10
<b>SECTION 3 - OVERVIEW</b>	<b>11-14</b>
3.0 Specifications & Listings (cULus)	11
3.1 Electrical Rating	11
3.1.1 Reels Not Equipped With Cable	11
3.1.2 Reels Equipped With Cable	11
3.2 Labels & Marking	11
3.2.1.1 Reels Equipped with Cable	11
3.2.1.2 Reels Not Equipped With Cable	11
3.3 Allowable Ampacities for Flexible Cord & Cable	12-13
3.4 Parts Breakdown	14
<b>SECTION 4 - INSTALLATION</b>	<b>15-23</b>
4.0 Application Types	15
4.0.1 Stretch Applications (Automatic)	15
4.0.2 Lift Applications (Extension or Automatic)	15
4.0.3 Drag Applications (Extension or Automatic)	15
4.0.4 Retrieve Applications (Automatic)	15
4.1 Mounting	15
4.1.1 Standard Mounting	15
4.1.2 Pivot Base Mounting	16
4.2 Guide Rails	16
4.3 Guide Rail Installation	16
4.4 Roller Guides	17
4.5 Ratchet	17
4.6 Ratchet Option Installation	18
4.6.1 Ratchet Pawl Installation	18
4.6.2 Ratchet Plate Installation	18
4.7 Spool Lock	19
4.7.1 Spool Lock Installation	19
4.8 Cable Installation & Replacement	20
4.8.1 Cable Removal	20
4.8.2 Cable Installation	20
4.8.3 Cable Connections	20
4.8.4 Cable Loading	20
4.9 Slip Ring Replacement	21

# TABLE OF CONTENTS

<b>SECTION 4 - INSTALLATION</b>	<b>15-23</b>
4.10 Electrical Connections	22
4.11 Spool Cable Connections	22
4.12 Supply Cable Connections	22
4.12.1 Reels Without Junction Boxes	22
4.12.2 Reels With Junction Boxes	22
4.13 Spring Tension Adjustment	23
4.13.1 Spring Cycling	23
4.13.2 Spring Pre-Tensioning	23
4.13.3 Adjusting Spring Tension	23
<b>SECTION 5 - OPERATION</b>	<b>24</b>
5.0 Operational Warnings	24
<b>SECTION 6 - MAINTENANCE</b>	<b>25-27</b>
6.0 Maintenance Warnings	25
6.1 Lubrication	25
6.2 Inspections	25
6.3 Spring Motor Replacement	26-27
<b>SECTION 7 - REPLACEMENT PARTS</b>	<b>28-31</b>
7.0 R Series Slip Rings for 1900 & 2400 Series	28
7.1 Reel Part Description	29
7.2 PowerReel Part Descriptions	30
7.3 GafferReel Part Descriptions (Theatre)	31
<b>SECTION 8 - TROUBLESHOOTING</b>	<b>32</b>
<b>NOTES</b>	<b>33</b>

# SECTION 1 - SAFETY

## 1.0 Safety Information Responsibility

- 1.0.1 All owner, operator, and maintenance personnel must read and understand all manuals associated with this product before installation, operation, or maintenance.
- 1.0.2 The manual provides information on the recommended installation, operation, and maintenance of this product. Failure to read and follow the information provided could cause harm to yourself or others and/or cause product damage. No one should install, operate, or attempt maintenance of this product prior to familiarizing themselves with the information in this manual.

## 1.1 Safety Messages

The following safety messages are used in this manual to alert you to specific and important safety related information.

### CAUTION

**CAUTION** indicates unsafe actions or situations that have the potential to cause injury, and/or minor equipment or property damage.

### DANGER

**DANGER** indicates hazards that have the potential to cause severe personal injury or death.

### WARNING

**WARNING** indicates unsafe actions or situations that have the potential to cause severe injury, death, and/or major equipment or property damage.

### NOTE

**NOTE** is used to alert you to installation, operation, programming, or maintenance information that is important, but not hazard related.

## 1.2 Limitation of Liability

- 1.2.1 All data and information in this mounting instructions have been compiled in compliance with the applicable standards and regulations, best practice and our many years of experience and knowledge.
- 1.2.2 The manufacturer accepts no liability for damages resulting from:
- Failure to comply with this document
  - Improper use
  - Use by untrained personnel
  - Unauthorized modifications
  - Technical changes
  - Use of unauthorized replacement parts and accessories
  - The actual scope of delivery may differ from the explanations and descriptions provided here if the model in question is a special one, if additional equipped has been ordered or due to recent technical changes.
- 1.2.3 The obligations agreed upon in the delivery agreement and our General Terms and Conditions of business apply, as do the delivery conditions of the manufacturer and the legal regulations applicable at the time the contract was concluded.
- 1.2.4 All products are subject to technical modifications in the context of improvement of function and further development.

## SECTION 1 - SAFETY

### 1.3. Personnel Requirements-Qualifications

#### **WARNING**

Inadequately trained persons are at risk of injury!

Improper use can result in serious personal injury or material damage. All activities must only be performed by qualified personnel.

1.3.1 Only persons who can be expected to perform their work reliably are acceptable personnel. People whose reactions are impaired by drugs, alcohol or medications, for example, are not authorized.

1.3.2 When selecting personnel, follow all age- and occupation-specific guidelines applicable at the location of use.

1.3.3 The following qualifications are specified in the operating instructions for certain fields of activity.

#### **1.3.4 Trained personnel and operators**

- Will have participated in a training session, given by the owner, on the tasks assigned to them and the potential hazards in case of improper conduct.
- The owner of the machine or system must document that the appropriate training has taken place.

#### **1.3.5 Specialist personnel**

- Will consist of persons capable of performing assigned tasks and independently identifying and avoiding potential hazards based on their specialist training, knowledge and experience as well as their knowledge of the applicable regulations. Persons are deemed to be technically qualified if they have successfully completed training as a master electrician, apprentice electrician, electrical engineer or electrical technician. Persons are also considered technically qualified if they have been employed in an appropriate capacity for several years, receiving theoretical and practical training in that line, and their knowledge and skills have been tested by a specialist in the appropriate field of training.
- The machine or system owner must document that the appropriate certificates or other proofs of qualification have been or are being provided.

### 1.4 Personnel Requirements-Unauthorized Personnel

#### **WARNING**

Danger due to unauthorized personnel!

Unauthorized persons who do not meet the requirements described here are not acquainted with the dangers in the working area. Keep unauthorized personnel away from the working area. In case of doubt, address the person and direct them away from the working area. Stop working, as long as unauthorized persons are in the working area.

# SECTION 1 - SAFETY

## 1.5 Personnel Requirements-Training

1.5.1 Before commissioning the equipment, personnel must be trained by the owner. Log the implementation of training for better traceability.

Example of a training log:

Date	Name	Training Type	Training Instructor	Signature
11/5/2019	John Doe	First safety training for personnel	Dave Miller	

## 1.6 Personal Protective Equipment

1.6.1 For every task, always use:

**Safety helmet:** For protection against falling or flying parts and materials.

**Protective gloves:** For the protection of hands against friction, scrapes, puncture or deeper wounds, as well as against contact with hot surfaces.

**Protective work clothing:** Primarily for protection against entrapment by moving machine parts. Work clothing must be close fitting with a low resistance to tearing; it must have close-fitting sleeves and no protruding parts.

**Protective footwear:** For protection against heavy falling parts and slipping on slippery floors.

For special tasks, specific protective equipment is required when executing particular tasks:

**Safety eye wear:** For eye protection against harmful influences such as strong light, chemicals, dust, splinters or weather effects.

**Hearing protection:** For protection against loud noises and to prevent acoustic trauma.

Breathing mask (FFP-3 - according to country-specific requirements): For protection against materials, particles, and organisms. In this case, for protection against the dust produced by the abrasion of carbon brushes and the PVC insulation of the conductor rail.

## 1.7 Electrical Warnings

1.7.1 This equipment should be properly grounded before use, in accordance with both the National Electric Code and local codes and ordinances.

1.7.2 The electrical power should be disconnected from the cable reel before any service functions are performed.

1.7.3 This cable reel must not be used for loads greater than the voltage and current rating of the cable. The ampacity rating of the cable reel shall be in accordance with the National Electric Code.1.2.1

## 1.8 Operational Warnings

1.8.1 Exercise care when handling the cable reel during normal operation. This cable reel has a rotating spool powered by springs under tension.

1.8.2 Do not use cable different from that for which the reel is intended. Changes in diameter, weight per foot, length of cable or flexibility will affect the operation of the reel.

1.8.3 Mounting hardware and fasteners should be installed to maintain tightness under vibration and checked periodically to assure tightness.

1.8.4 Overhead installation mountings should be such that the reel is not supported by bolts in tension. A safety chain or cable is strongly recommended to minimize damage and/or possible injury in the event of mounting failure.



## SECTION 1 - SAFETY

### 1.9 Maintenance Warnings

#### **WARNING**

Modification of this equipment may cause excessive wear and will void the warranty. Contact the manufacturer regarding changes or modifications of equipment which could affect reliability or safety.

#### **WARNING**

**DO NOT DISASSEMBLE THE SPRING MOTOR FOR ANY REASON.** Serious personal injury could result. This cable reel is equipped with springs under tension. Contact the factory for assistance.

In the US call: 1 800-521-4888
--------------------------------

In the Canada call: 1 800-667-2487
------------------------------------

## SECTION 2 - PRODUCT DISPOSAL

### 2.0 Product Disposal and Recycling

2.0.1 Once the product has reached its end of life it must be disassembled and disposed of in accordance with local and regional environmental requirements.

2.0.2 In the absence of a return and disposal agreement, disassembled components must be recycled as follows:

- All metallic parts must be sorted and recycled by material type
- All plastic components must be sorted and recycled by material type
- All other components are to be disposed of in accordance with their material composition. Take care with items identified as Substances of Concern.

2.0.3 Local authorities or special disposal companies can provide information about environmentally appropriate disposal.

## SECTION 3 - OVERVIEW

### 3.0 Specifications & Listings (cULus)

3.0.1 The following specifications apply to standard 1900 & 2400 Series Cable PowerReels:

- 1900 & 2400 Series Cable Reels are intended for commercial / industrial use and are provided with a permanent mounting base.
- 1900 & 2400 Series Cable Reels are built to NEMA 4 Specifications and are suitable for indoor/outdoor use.
- Spring Motors for the 1900 & 2400 Series are sealed for safety and weather-tight for long-life.
- Ampere capacity of the 1900 & 2400 Series Reels range from 6.5 to 150 Amperes and from 250 to 600 Volt maximum. Reels are available in 2 to 30 conductor configuration.
- 1900 & 2400 Series Cable Reels are available with optional features which increase safety, enhance performance, and improve serviceability. Options include: ratchet, pivot base, spool lock, junction box, and guide rails.
- Custom power and signal circuit slip rings using silver plated slip rings and silver graphite brushes are available on request.

### 3.1 Electrical Rating

#### 3.1.1 Reels Not Equipped With Cable

- Reels not equipped with flexible cable are rated in Amperes and volts. Consult the tables on the following pages for appropriate cable/conductor combinations.
- The amp and voltage rating of the cable should not be greater than the slip ring circuit. See Slip Ring Replacement Chart and consult the tables on the following pages for appropriate cable/conductor combinations.

#### 3.1.2 Reels Equipped With Cable

- Reels equipped with flexible cable should not be used at voltages and/or amperages above the rating of the reel or the cable.

### 3.2 Labels & Marking

3.2.1 Every cable reel is marked with a label on the frame which includes the Conductix name and logo, the product catalog number and the individual product serial number.

#### 3.2.1.1 Reels equipped with cable:

- The marking on reels equipped with a flexible cable shall include the current and voltage ratings.

#### 3.2.1.2 Reels not equipped with cable:

3.2.1.2.1 The rating of the reel not equipped with cable is completed upon installation and is based on the wire size and number of conductors. See Tables below. The marking shall include the following:

- The type (SOW, W, G-GC, etc.),
- The AWG cable size,
- The maximum length of cable with which the reel is intended for use.

3.2.1.2.2 The maximum amperage and voltage rating for cable reels supplied without cable is on the Conductix Identification label. Actual rating is determined by the installed cable, wire size and number of conductors, and is not to exceed the indicated maximum rating of the slip ring.

3.2.1.2.3 The cable reel is designed to handle cable with a temperature rating of up to 90° C, which is marked on the cable.

## SECTION 3 - OVERVIEW

### 3.3 Allowable Ampacities for Flexible Cord & Cable

Type W (90°C)							
Cable	Ampacity	Cable	Ampacity	Cable	Ampacity	Cable	Ampacity
W 8/2	50	W 6/2	65	W 4/2	90	W 2/2	120
W 8/3	50	W 6/3	65	W 4/3	85	W 2/3	115
W 8/4	45	W 6/4	55	W 4/4	75	W 2/4	100
						W 1/2	140

**Table 3-1**

Type G-GC (90°C)	
Cable	Ampacity
8/3 G-GC	50
6/3 G-GC	65
4/3 G-GC	85
2/3 G-GC	115

**Table 3-2**

G-GC Cable Color Code Chart		
Conductor No.	Base Color	Tracer Color
1	Green	-
2	Green	-
3	Yellow	-
4	Black	-
5	White	-
6	Red	-

**Table 3-3**

## SECTION 3 - OVERVIEW

### 3.3 Allowable Ampacities for Flexible Cord & Cable

Type SOW-A, S00W-A (90°C)							
Cable	Ampacity	Cable	Ampacity	Cable	Ampacity	Cable	Ampacity
16/2	13	14/2	15	12/2	20	10/2	25
16/3	10	14/3	15	12/3	20	10/3	25
16/4	8	14/4	12	12/4	16	10/4	20
16/5	8	14/5	12	12/5	16	10/5	20
16/6	8	14/6	12	12/6	16	10/6	20
16/7	7	14/7	10.5	12/7	14	10/7	17.5
16/8	7	14/8	10.5	12/8	14	10/8	17.5
16/10	7	14/10	10.5	12/10	14	10/10	17.5
16/12	7	14/12	10.5	12/12	14	10/12	17.5
16/14	7	14/14	10.5	12/14	14	10/14	17.5
16/16	7	14/16	10.5	12/16	14	10/16	17.5
16/20	7	14/20	10.5	12/20	14	10/20	17.5
16/24	6	14/24	10.5	12/24	14	-	-
16/30	6	14/30	9	12/30	12	-	-

**Table 3-4**

Color Code Chart								
Conductor No.	Base Color	Tracer Color	Conductor No.	Base Color	Tracer Color	Conductor No.	Base Color	Tracer Color
1	Green	-	11	Blue.Black	Black	21	Orange	Green
2	Black	-	12	Black	White	22	Black	-
3	White	-	13	Red	White	23	White	-
4	Red	-	14	Green	White	24	Red	-
5	Orange	-	15	Blue	White	25	Green	-
6	Blue	-	16	Black	Red	26	Orange	-
7	White	Black	17	White	Red	27	Blue	-
8	Red	Black	18	Orange	Red	28	White	Black
9	Green	Black	19	Blue	Red	29	Red	Black
10	Orange	Black	20	Red	Green	30	Green	Black

**Table 3-5**

# SECTION 3 - OVERVIEW

## 3.4 Parts Breakdown

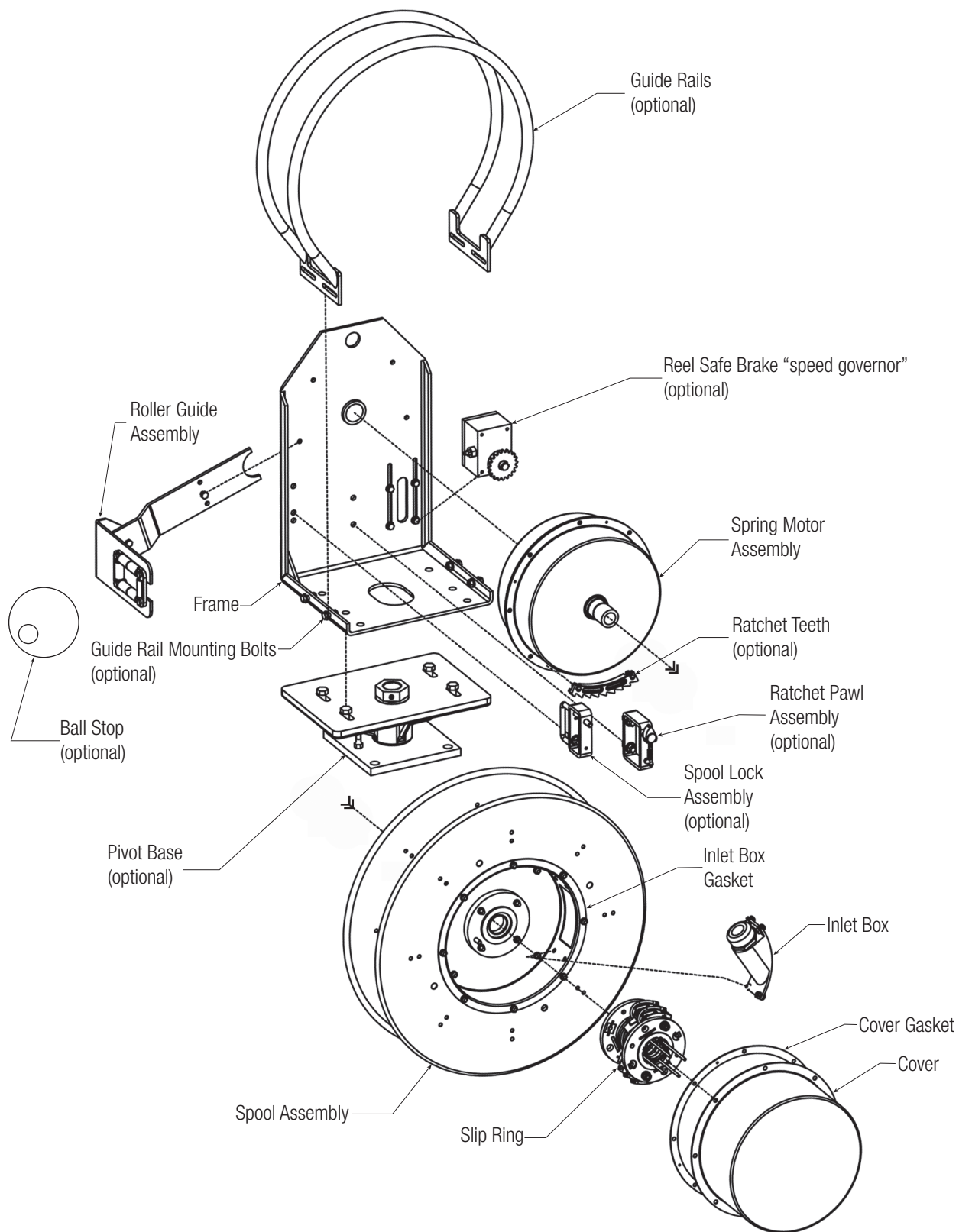

## SECTION 4 - INSTALLATION

### 4.0 Application Types

#### 4.0.1 Stretch Applications (Automatic)

4.0.1.1 The cable is suspended without any intermediate support. Stretch reels generally require a line pull equal to two times the weight of the cable, which allows approximately 10% sag at full extension. On long applications where sag cannot be tolerated, it is sometimes desirable to put supports at intervals of 5 to 10 feet. See Figure 4-1.



Figure 4-1

#### 4.0.2 Lift Applications (Extension or Automatic)

The cable is lifted vertically in lift applications. The reel is normally designed to handle only the total weight of the cable. Some lift applications may require a ball stop and ratchet to control the length of cable to be retracted. All standard 1900/2400 Series lift reels sold with cable have a ball stop and ratchet installed on the reel. See Figure 4-2.

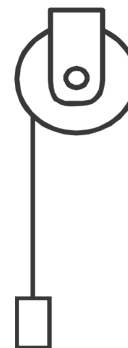

Figure 4-2

#### 4.0.3 Drag Applications (Extension or Automatic)

The reel is mounted on a stationary object and is required to drag the cable over the surface to the reel. The cable is supported by the ground or some type of cable tray. A ball stop is required. All standard 1900/2400 Series drag reels sold with cable have a ball stop and ratchet installed on the reel. See Figure 4-3.

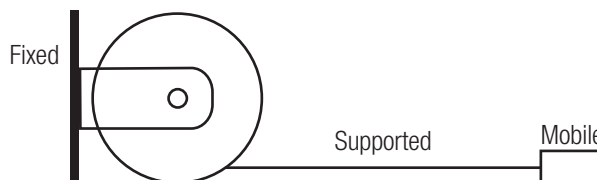

Figure 4-3

#### 4.0.4 Retrieve Applications (Automatic)

The reel is mounted on the moving object and winds up or pays out the cable as the machine approaches or moves away from the fixed end. Retrieve applications can be elevated up to 4 feet from the cable support surface. See Figure 4-4.

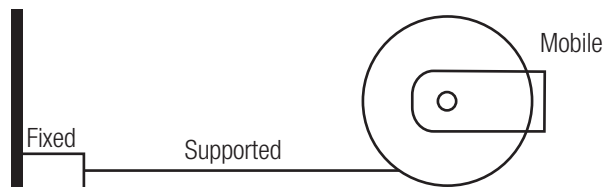

Figure 4-4

### 4.1 Mounting

#### 4.1.1 Standard Mounting

4.1.1.1 Mount the base of the reel to any flat surface. The surface must be strong enough to support the reel and the forces of winding and unwinding the cable.

1. The spool drum must be mounted horizontally.
2. The cable should extend perpendicular to the rotation of the spool. The total cable deflection should not exceed  $15^\circ$  to either side of the center line of the spool. See Figure 4-5.
3. If deflection is constant to either side of the reel and operation is impaired, re-mount the reel.
4. If the angle of deflection exceeds  $30^\circ$ , a Pivot Base or two way payout guide should be used, otherwise excessive cable wear and unreliable operation will result.
5. A safety chain is recommended for all overhead installations. Attach the safety chain using the 0.39" hole provided in the base.

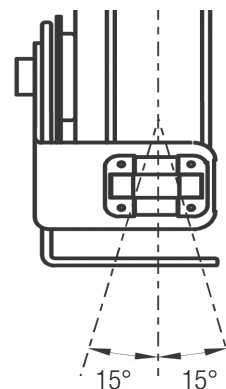

Figure 4-5

## SECTION 4 - INSTALLATION

### 4.1.2 Pivot Base Mounting

4.1.2.1 All 1900 & 2400 Series Cable Reels can be furnished with a pivot base to allow the reel to rotate and keep the extended cable perpendicular to the application. **See Figure 4-6.**

4.1.2.2 Pivot Bases rotate up to 345°. If 360° rotation is required contact the factory.

4.1.2.3 A pivot base is required in carousel or loop-track applications.

4.1.2.4 When a pivot base is used the reel must be mounted horizontally (“ceiling” or “floor” mounted).

4.1.2.5 The Roller Guide should be mounted so that the cable will travel perpendicular to the axis of pivot base rotation. This will guard against cable twisting and ensure effective swivel action from the pivot base.

4.1.2.6 Mount Pivot Base in the position that best centers the spool over the pivot axis.

### 4.2 Guide Rails

4.2.1 All 1900 & 2400 Series Cable Reels can be furnished with a pivot base to allow the reel to rotate and keep the extended cable perpendicular to the application. **See Figure 4-7.**

4.2.2 Pivot Bases rotate up to 345°. If 360° rotation is required contact the factory.

4.2.3 A pivot base is required in carousel or loop-track applications.

4.2.4 When a pivot base is used the reel must be mounted horizontally (“ceiling” or “floor” mounted).

4.2.5 The Roller Guide should be mounted so that the cable will travel perpendicular to the axis of pivot base rotation. This will guard against cable twisting and ensure effective swivel action from the pivot base.

4.2.6 Mount Pivot Base in the position that best centers the spool over the pivot axis.

### 4.3 Guide Rail Installation

1. Guide Rails are mounted to the base using the same bolts that mount the reel.

**NOTE:** Later versions may have guide rails mounted on sides of the base.

2. Mount Rails as shown in **Figure 4-7.**

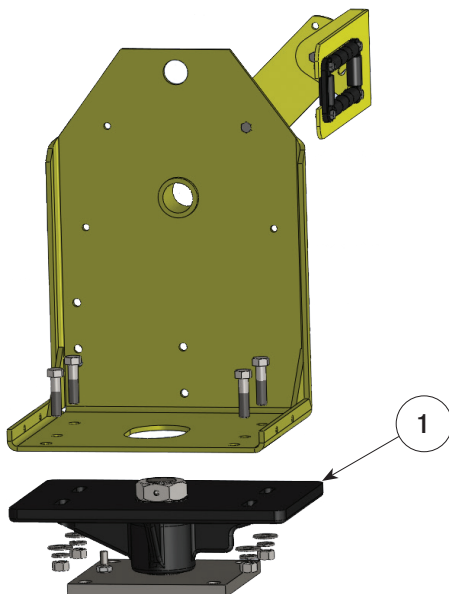

Figure 4-6

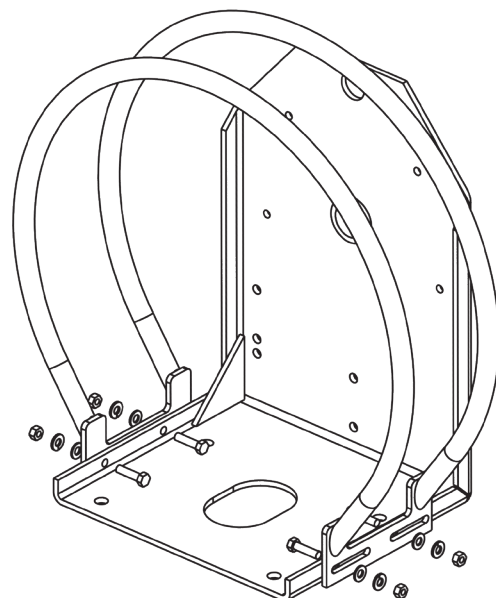

Figure 4-7



## SECTION 4 - INSTALLATION

### 4.4 Roller Guides

4.4.1 All 1900 & 2400 Series Cable Reels are equipped with an adjustable roller guide. The guide's function is to center the cable on the spool and to help the reel wrap cable more evenly.

4.4.2 Level winding is inhibited by the cable bearing against either of the spool flanges during operation. The Roller Guide helps to alleviate this condition.

4.4.3 The guide consists of two elements: the guide arm and the guide head. The guide must be adjusted and secured prior to terminating any electrical connections. **See Figure 4-8.**

1. The guide should be secured at the position that causes the least change of cable direction to occur at the guide; otherwise, cable life will be reduced.
2. Mount the guide arm to the base by positioning the open end of the arm against the groove between the shaft coupling and the frame. Secure the guide arm using the provided 5/16-18 hex head cap screw, spring-type lock washer, and 5/16-18 hex nut. There are four holes in the frame and three holes in the arm to provide a total of 12 possible mounting positions.
3. The guide head may be adjusted freely through 60° degrees for applications that require precise alignment.
4. Attach the guide head to the end of the guide arm using the provided hardware.
5. Cable can be released for maintenance by removing the rollers on the Guide Head without disconnecting the cable.

### 4.5 Ratchet

4.5.1 The ratchet option allows the extended cable to be pulled out and held from retraction by spring tension; generally appropriate for operator attended applications. **See Figure 4-9.**

4.5.2 The ratchet for the 1900 & 2400 Series Cable Reels is spring loaded. It is designed to function in all acceptable mounting configurations.

4.5.3 The ratchet option can be installed at the time of purchase or later added to reels that have already been introduced to service.

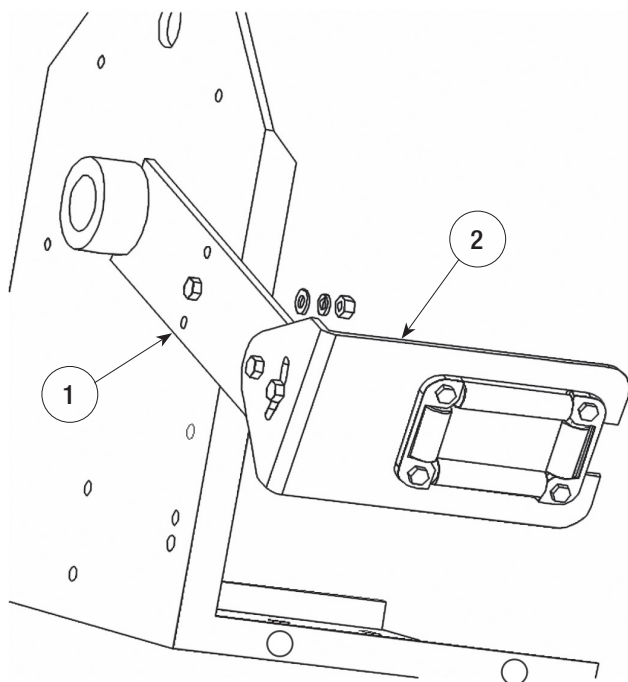

**Figure 4-8**

1. Guide Arm
2. Guide Head

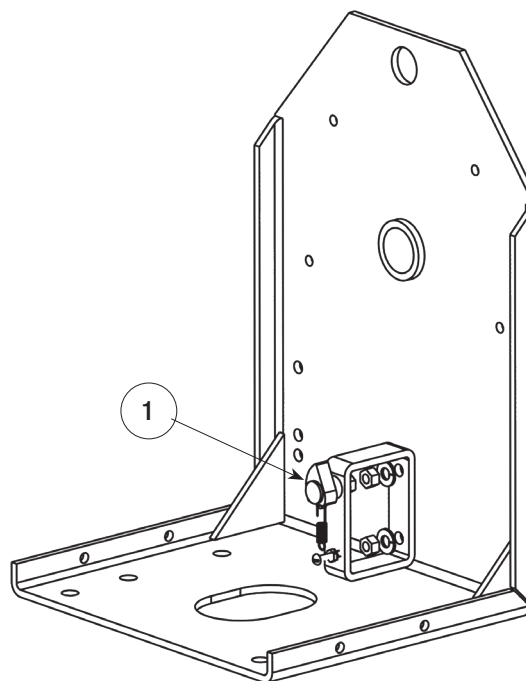

**Figure 4-9**

1. Ratchet

## SECTION 4 - INSTALLATION

### 4.6 Ratchet Option Installation

#### **WARNING**

Power should be disconnected from the reel before beginning any service or maintenance functions. Follow lock-out/tag-out procedures appropriate to the installation.

#### 4.6.1 Ratchet Pawl Installation

The ratchet pawl assembly is attached to the reel frame as a unit. The holes provided for the attachment of The ratchet pawl assembly are located in the lower middle area of the frame.

1. Insert the two provided 3/8-16x1" bolts in the frame. **See Figure 4-10.**
2. Position the ratchet pawl assembly over the protruding bolt shafts.
3. Secure using the two provided sets of 3/8-16 hex nuts & lock washers.

#### 4.6.2 Ratchet Plate Installation

The cable must be extended far enough to allow the removal of the two spring-side flange bolts that are aligned with the cable entrance (see item 1 in the **figure 4-10** below).

1. Substitute the provided longer flange bolts and nuts for the removed bolts and nuts.
2. Position the ratchet plate over the bolts on the outside of the spring-side flange. When viewed from the frame, the square tooth of the ratchet plate should be to the left-hand side.
3. Secure the ratchet plate to the spool by tightening the nuts to approximately 7 ft-lbs.
4. Additional ratchet plates may be installed but will increase the likelihood of spool lock-up at full cable extension.

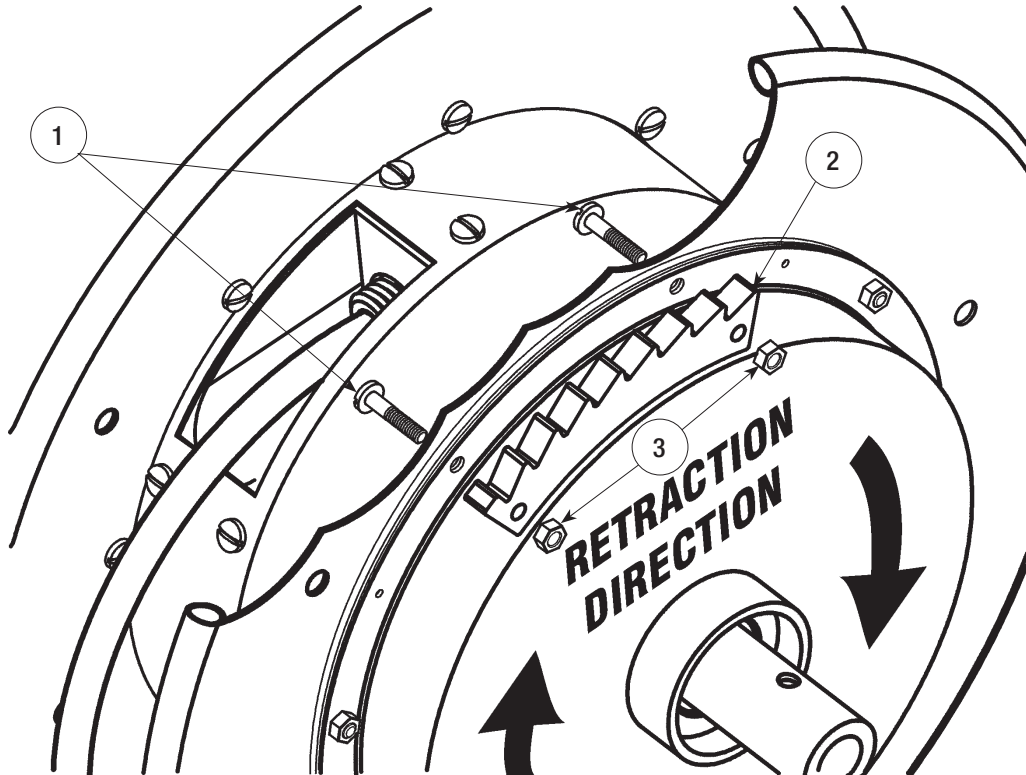

**Figure 4-10**

1. 3/8"-16x1" Bolts
2. Ratchet Paw Assembly
3. 3/8-16 Hex Nuts

## SECTION 4 - INSTALLATION

### 4.7 Spool Lock

4.7.1 All 1900 & 2400 Series Cable Reels can be equipped with an optional Spool Lock. See Figure 19-1.

4.7.2 The Spool Lock allows the power spring tension to be locked out from the cable spool. Applications that often require cable replacement would benefit from the addition of the Spool Lock.

4.7.3 The spring-loaded design of the Spool Lock maintains engagement under conditions of shock and vibration. This is good for applications which require the cable to remain extended and are subject to severe service conditions.

#### 4.7.1 Spool Lock Installation

1. Attach the spool lock riser with 3/8-16 x 3/4 bolt finger tight.
2. Insert the lock into the hole in the frame and the first riser hole. Place the spring on the lock shaft before it goes through the second riser hole. See Figure 19-1.
3. Hold the spring back and insert a roll pin to keep the spring in position. Use the provided insert tool to center the roll pin through the shaft.
4. Tighten the mounting bolt.

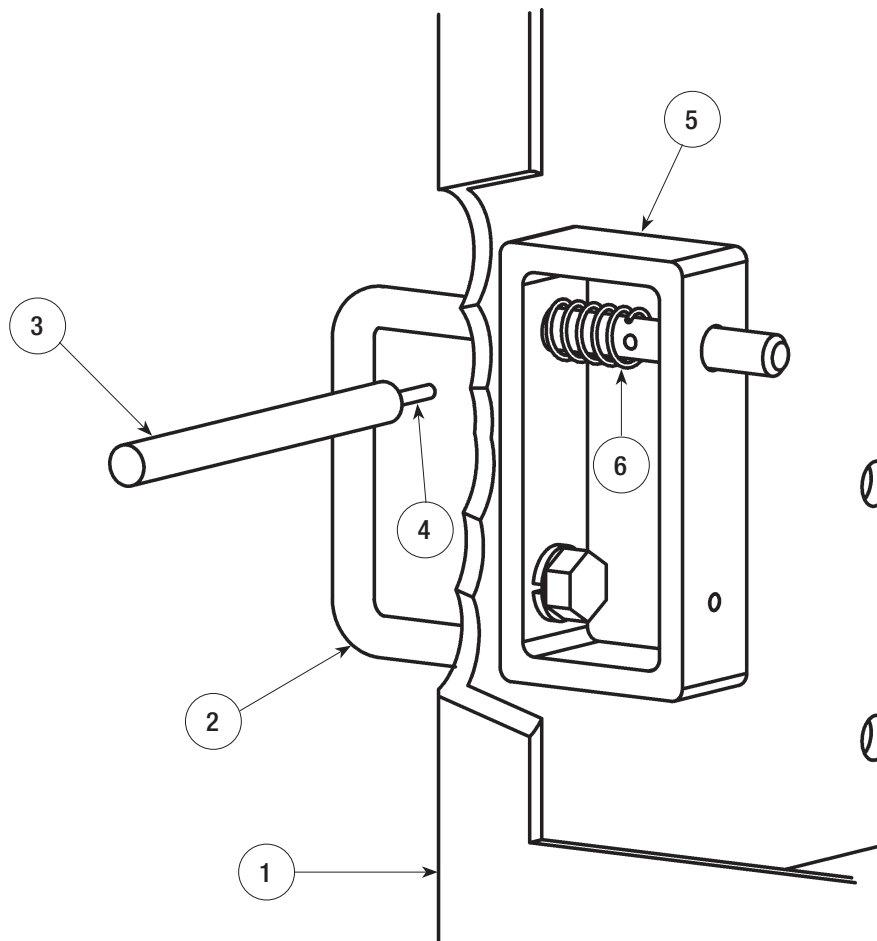

**Figure 4-11**

- |                         |             |
|-------------------------|-------------|
| 1. Base                 | 4. Roll Pin |
| 2. Spool Lock Shaft     | 5. Riser    |
| 3. Roll Pin Insert Tool | 6. Spring   |

## SECTION 4 - INSTALLATION

### 4.8 Cable Installation & Replacement

#### 4.8.1 Cable Removal

4.8.1.1 If an existing cable is being replaced you must first remove the old cable.

1. Disconnect all power as per Lock-Out/Tag-Out procedures as outlined in OSHA Section 1910.147.
2. Remove the Slip Ring Cover.
3. Mark existing cable connections.
4. Disconnect wires at the Slip Ring Brush Terminals.
5. Loosen the cable clamp and release the cable.
6. Loosen strain relief/watertight in the recessed Inlet Box on the spool.
7. Pull out and discard the old cable.

#### 4.8.2 Cable Installation

1. Prepare the cable to be loaded onto the reel. Support the cable as shown, or lay the full length of cable out in the direction of travel. Make sure the cable will lay flat by removing any twist from the cable. All weld cable lead ends should be tinned for optimal performance. **See Figure 4-12.**
2. Insert the end of the cable to be connected to the slip ring through the guide arm and through the recessed inlet box on the spool. Pull enough cable through the inlet box and cable clamp to allow unstrained connections to the slip ring.
3. Unscrew the two parts of the strain relief/watertight and slide both sections and the neoprene grommet over the end of the cable as shown. Be sure to keep the fastening end last.

#### 4.8.3 Cable Connections

1. Connect the cable to the Slip Ring terminals. Verify that the cable leads do not interfere with the free running of the slip ring brushes. For additional information on wiring see Slip Ring Installation & Replacement.
2. Secure the watertight connector. Jacketed cable should intrude 4-5 inches into the drum. Smaller watertights are secured using a Bridgeport sealing nut. **See Figure 4.13.**

#### 4.8.4 Cable Loading

1. Wind the cable onto the spool by rotating the spool counterclockwise, as viewed from the slip ring cover.
2. Follow Spring Tensioning Procedure to adjust the spring tension as required by the application.
3. Verify all connections before initiating or restoring electrical power to the cable reel.
4. Visually inspect both reel and cable after initial electrification.

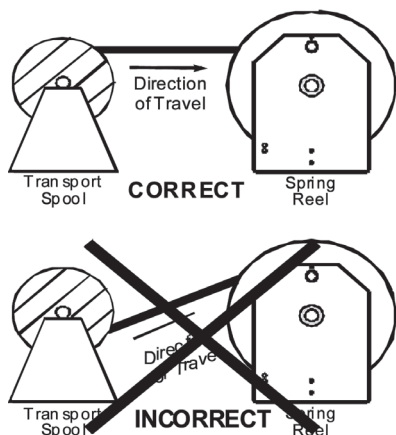

Figure 4-12

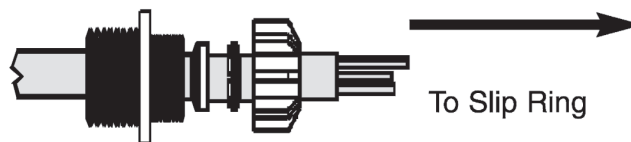

Figure 4-13

## SECTION 4 - INSTALLATION

### 4.9 Slip Ring Replacement

1. Disconnect and secure the electrical power as per Lock-Out/Tag-Out procedure outlined in OSHA 1910.147.
2. Remove the Slip Ring cover.
3. Disconnect the Spool Cable Connections from the Slip Ring Brush Terminals. Mark/Note the existing cable connections. **See Figure 4-14.**
4. Disconnect the Slip Ring Core Leads from the Junction Box terminals or, if there is no Junction Box, cut the wire as close as possible to the crimp connector. **See Figure 4-15.**
5. Loosen the two 1/4-20 Set Screws in the drive collar using a 1/8" Hex (Allen) Wrench.
6. Remove the Slip Ring from the end of the spool shaft.
7. After removing the Slip Ring use sand paper to remove the set screw burrs from the spool shaft. If the burrs are not removed the Slip Ring may not slide on the shaft.
8. Install the new Slip Ring on the shaft.
9. Be sure the hole in the Slip Ring Outboard Bearing closest to Brush #2 fits over the DrivePin. The Drive Pin must extend through the hole.
10. Secure Set Screws to 7 ft-lbs.
11. Connect the new Slip Ring to both the Spool Cable and Feeder Wire Connections.

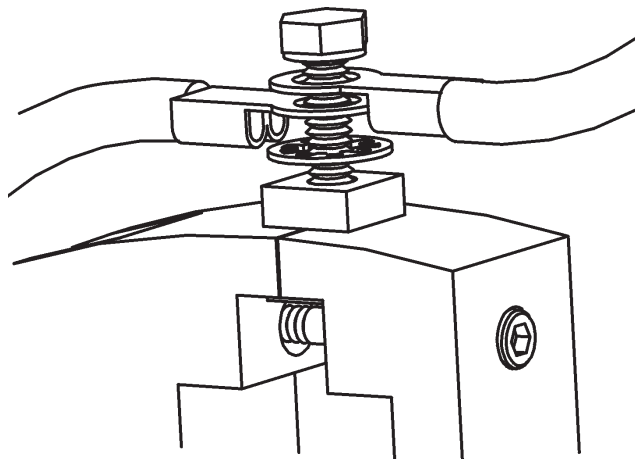
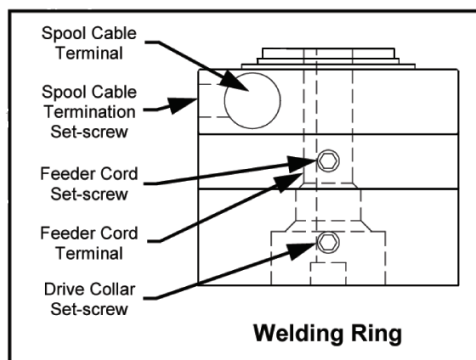

Figure 4-14

### ⚠ CAUTION

Incorrect Connection of Lead Terminals Will Result in Unit Failure

**NOTE:** Keep Spool Cable Connections Clear of Slip Ring Brushes



Feeder Cable Connections  
(may be at the ring or at the shaft/junction box)

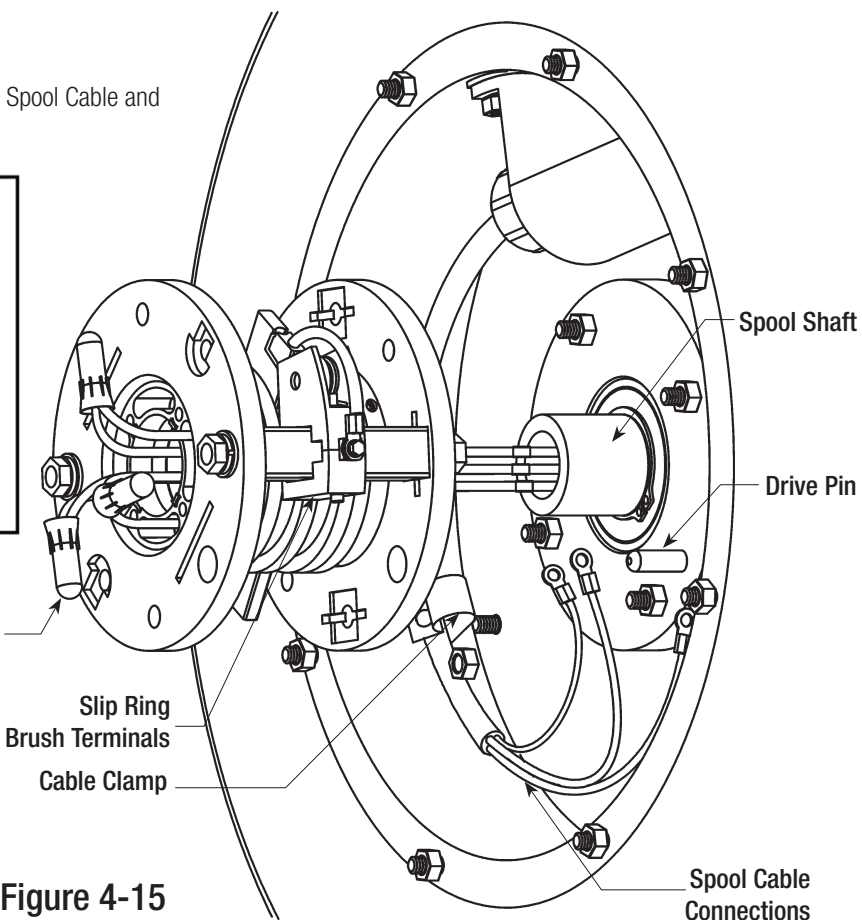

Figure 4-15

## SECTION 4 - INSTALLATION

### 4.10 Electrical Connections

#### WARNING

- 4.10.1 Electrical connections are determined by the requirements of the application and the configuration of the reel.
- 4.10.2 All electrical work should be performed by a qualified electrician.
- 4.10.3 Factory installed cable is wired with ring one (the ring closest to the drive collar) designated as ground, wired with the green cable conductor. **See Figure 4-16.**
- 4.10.4 A continuity check should be performed prior to energizing the reel to verify electrical connections.

### 4.11 Spool Cable Connections

- 4.11.1 See Cable Installation & Replacement Section for information on connecting the cable from the spool to the slip ring.

### 4.12 Supply Cable Connections

#### 4.12.1 Reels without Junction Boxes

- Standard 1900 & 2400 Cable Reels do not have junction boxes for electrical connections.
- Reels without junction boxes are intended to have the supply cable attached by either conduit or water tight fitting installed into the 1" NPT internal threads at the end of the shaft.
- The nylon bushing in the end of the shaft is there to protect the wire leads from the threads in the shaft during shipping. THE NYLON BUSHING MUST BE REMOVED DURING INSTALLATION OF THE REEL.
- Supply cable connections are made either at the top of the slip ring or at the shaft entrance using crimp connections.
- Connections made at the slip ring require adequate clearance. After making all connections, wire leads should be bent to clear both the brush post screw thread and the inside of the slip ring cover. **See Figure 4-17.**

#### 4.12.2 Reels with Junction Boxes

- NEMA 4 rated junction boxes are available for the 1900 & 2400 Series Cable Reels. Overall dimensions vary depending on AWG wire size and number of conductors and rating classification. **See Table 4-1.**
- Junction Box Terminals are numbered from the top down, left to right.
- Terminal 1 is designated as Ground.
- Slip Ring conductors are wired to the inside of the terminals.
- Torque terminal screws to 25-30 in-lbs.

Junction Box Terminal Location
A = 1-12 Conductors
B = 13-24 Conductors
C = 25-36 Conductors

Table 4-1

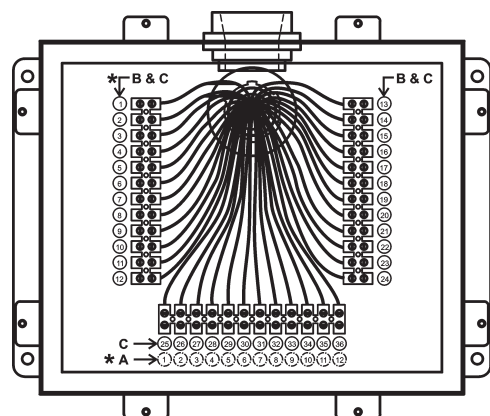

Figure 4-16

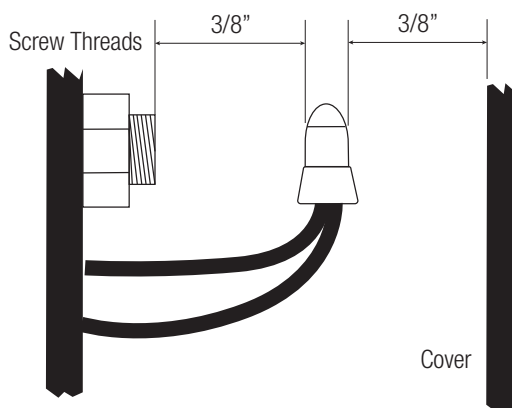

Figure 4-17

## SECTION 4 - INSTALLATION

### 4.13 Spring Tension Adjustment

#### NOTE:

- More demanding applications may require spring tension adjustments for proper cable retraction.

#### WARNING

Do not allow cable to retract without restraining the retraction speed. Walk the cable back to the reel. The retraction speed should not exceed 150 ft/min.

#### 4.13.1 Spring Cycling

- 4.13.1.1 The spring should be cycled after mounting but before terminating the free end to assure that the cable will retract properly and operate under the correct tension.
- 4.13.1.2 This is accomplished by pulling the cable out the required distance and allowing it to rewind. This procedure should be performed five to ten times. **See Figure 4-18.**

#### 4.13.2 Spring Pre-Tensioning

- 4.13.2.1 The proper pre-tensioning required for effective operation varies by cable diameter and cable weight. Trial and error are the most effective means of setting the proper spring pre-tension. Pre-tensioning is achieved by pre-loading the spring with setup turns (reel revolutions). **See Figure 4-19.**

1. Relieve the spring of all tension before putting on setup turns. Grasp the end of the cable and the spool and rotate both spool and cable together in the payout direction until the spring engages.
2. Single Spring Motors (L, E, F) and Parallel Spring Motors (LP, EP, FP) require two setup turns. Series Spring Motors (LS, ES, FS) require four setup turns.
3. Next, feed the end of the cable through the roller guide (if present) and test the Spring Tension. Pull the cable out the required distance and allow it to rewind.

#### 4.13.3 Adjusting Spring Tension

- 4.13.3.1 One additional setup turn may be added to provide increased tension if the total number of spool revolutions required to fully retract the cable plus the setup turns is less than the maximum number listed in the table below. One setup turn can be removed if the torque is too high. **See Figure 4.-20.**
- 4.13.3.2 Do not add or remove setup turns on the reel after the cable has been terminated. The resulting twist may kink the cable and shorten cable life.
- 4.13.3.3 Secure the end of the cable using the appropriate terminals.

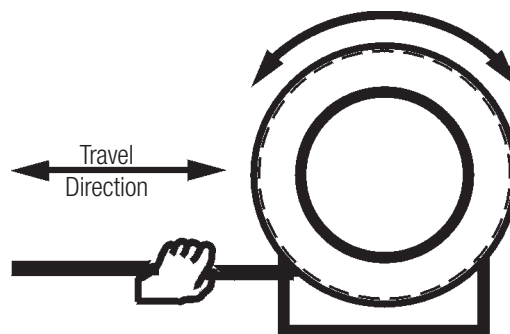

Figure 4-18 View from Outer Flange

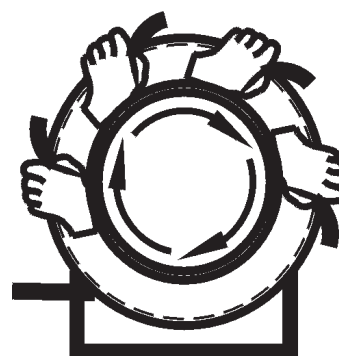

Figure 4-19 View from Outer Flange

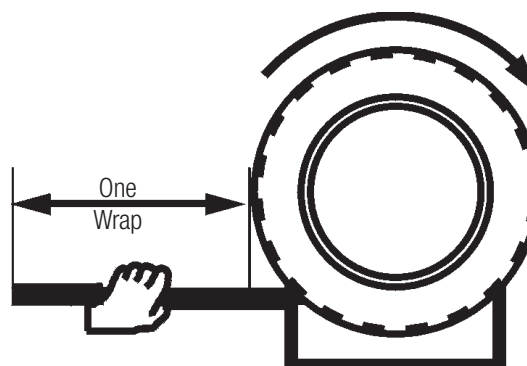

Figure 4-20 View from Outer Flange

MAXIMUM USABLE SPRING TURNS	
Spring Motor	Turns
E, EP, F, FP	15
L,LP	22
ES, FS	30
LS	44

Table 4-2

## SECTION 5 - OPERATION

### 5.0 Operational Warnings

#### **WARNING**

- Do not exceed the voltage or ampere rating of the reel. Overheating, fire, damage to equipment or personal injury could result. Do not allow cable to retract without restraining the retraction speed.
- Operate the reel within the cable size and length and spring tensioning limits for which it was intended.
- Two wraps of cable should remain on the reel at maximum extension to avoid excessive tension on the cable entrance watertight and slip ring terminations.
- The spring should not be wound to the last two turns at maximum payout. This prevents over-stressing the spring(s), thus reducing its life or damaging the reel.
- Keep the reel and cable clean to avoid excessive wear and damage.
- Arrange for maintenance service if damage is found on the cable or reel.
- To maximize spring life, cable should be fully retracted when not in use.



## SECTION 6 - MAINTENANCE

### 6.0 Maintenance Warnings

#### WARNING

- Be sure the power is off for maintenance.
- Follow lock-out/tag-out procedures as outlined in OSHA Section 1910.147.

### 6.1 Lubrication

6.1.1 All springs and bearings are lubricated for life at the factory. Additional lubrication should not be required.

6.1.2 Do not apply any lubricants or solvent cleaning agents to the slip ring, brush, or insulator surfaces.

### 6.2 Inspections

6.2.1 Check the reel every 200-400 operating hours for any loose or missing fasteners. Tighten or replace as necessary.

6.2.2 The slip ring assembly should be checked periodically as follows:

1. Clean to remove any accumulated dust or dirt from the slip ring housing area.
2. Check all brush and ring surfaces in the slip ring assembly and remove any accumulated dust.
3. Brushes should be centered on the slip rings and brush springs should be seated in the slot on top of the brush. Terminal screw connections should be tight.
4. Replace Brushes when the brush spring is within 0.093" of the ring insulator. **See Figure 6-1.**
5. Inspect cable for damage or wear which would make it unsafe to use.

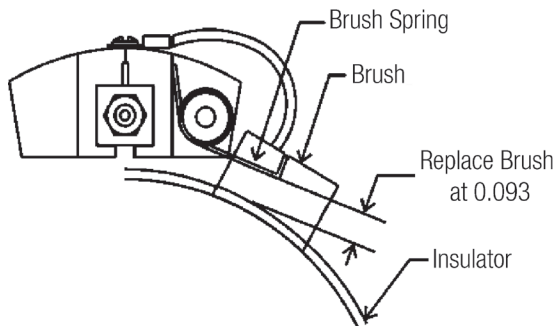

Figure 6-1

## SECTION 6 - MAINTENANCE

### 6.3 Spring Motor Replacement

1. Disconnect Power (as per Lock-Out/ Tag-Out Procedures).
2. Some procedures may require mechanical assistance. The combined weight of the Cable, Spool, and Spring Motor may exceed 200 lbs.
3. Disconnect the terminated end of the cable. Wrap the cable onto the Reel Spool. Secure the cable on the spool using a zip-tie or similar fastener.
4. Make sure all spring tension is released and that the ratchet plate is free of the ratchet pawl.
5. Remove the Slip Ring Cover, Gasket, and Slip Ring as per Slip Ring Replacement Section. **See Figure 6-2.**
6. Remove any junction box, conduit connection or collar attached to the threaded end of the shaft.
7. Remove the service/feeder cable.
8. Remove the 1-1/2" Snap ring securing the Spool on the shaft. See Figure 6-3.
9. Loosen the 1/2-13 set screw in the Frame Hub using a 1/4 Hex (Allen) Wrench. See Figure 6-5.
10. The Spool and Spring Motor Assembly are removed by sliding the shaft out of the frame assembly.
11. Lay the Spool down with the Spring Motor Shaft pointing up.
12. Remove the eight 1/4-20 Keps Nuts that fasten the Spring Motor to the Spool. Remove the Ratchet Teeth, making note of their position(s) if present, and set aside. See Figure 6-4.
13. Mount the new Spring Motor to the Spool. See Figure 6-4.
14. Remount, making sure the hole in the shaft is aligned to the set screw hole in the frame hub. Torque the Spring Motor Nuts to 4 ft-lbs. Secure the 1/2-13 set screw in the Frame Hub to 28-35 ft-lbs using a 1/4 Hex (Allen) wrench. See Figure 6-4.
15. Reassemble.
16. Perform the Spring Tension Adjustment procedures.
17. Return the Reel to service.

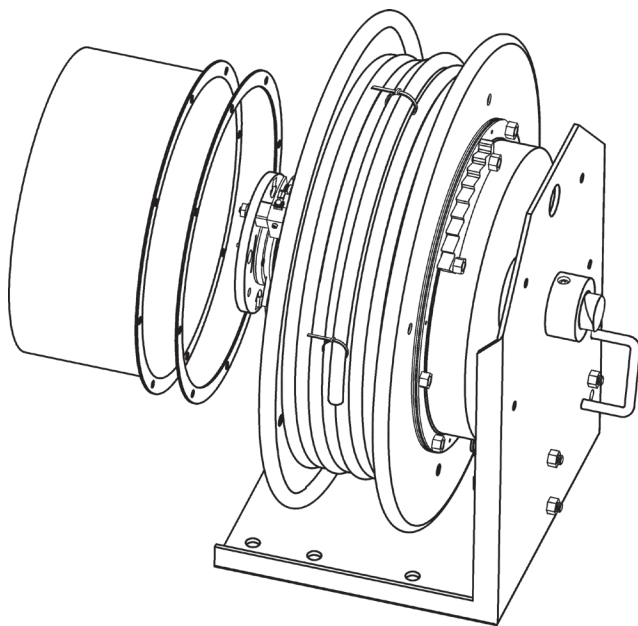

Figure 6-2

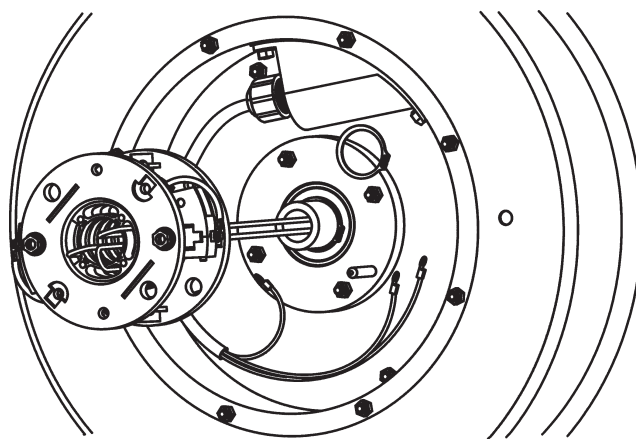
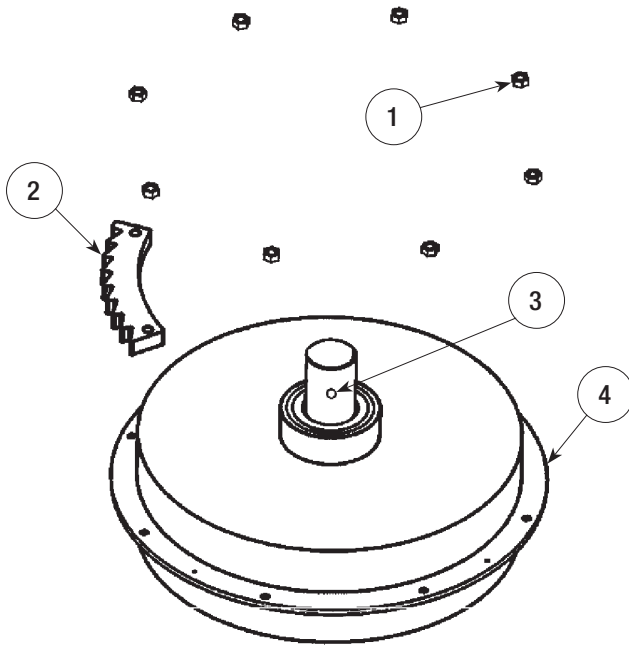

Figure 6-3

## SECTION 6 - MAINTENANCE



**Figure 6-4**

1. 1/4-20 Keps Nut
2. Ratchet Teeth (optional)
3. Set Screw Alignment Holder
4. Spring Motor

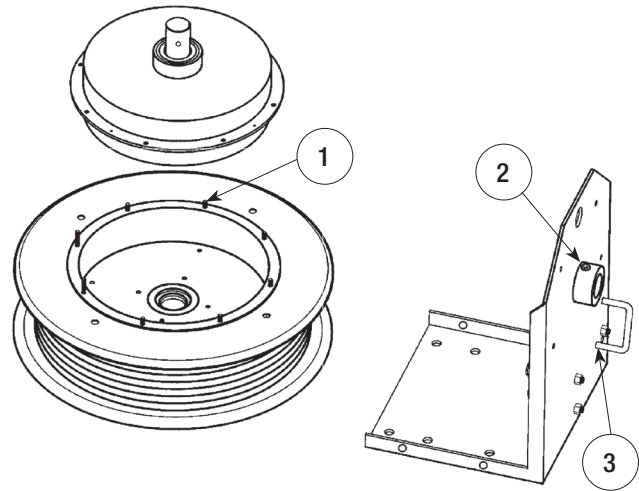

**Figure 6-5**

1. Ratchet Plate Studs (longer than others)
2. Frame Hub Set Screw
3. Spool Lock (optional)

# SECTION 7 - REPLACEMENT PARTS

## 7.0 R Series Slip Rings for 1900 & 2400 Series

7.1.1 To identify the slip ring in 1900 & 2400 Series reels for Replacement parts, it is necessary to precede the amperage profile section with the product code "RA-". This code specifies that the Slip Ring is a member of the R Series Slip Ring family and designates the bore size as 1.50".

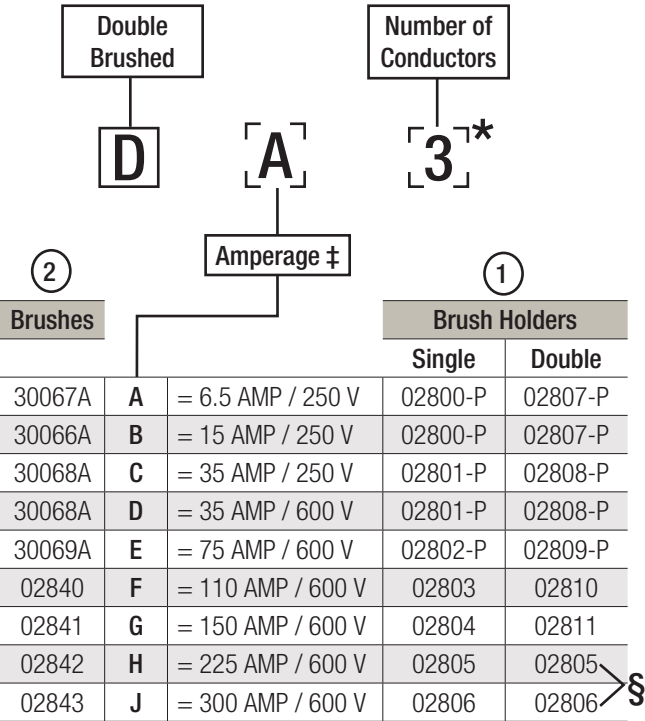

‡ Multiple Amperage Sections are possible.  
 \* Consult the factory for Custom Application Part Numbers  
 § Available for Special Applications

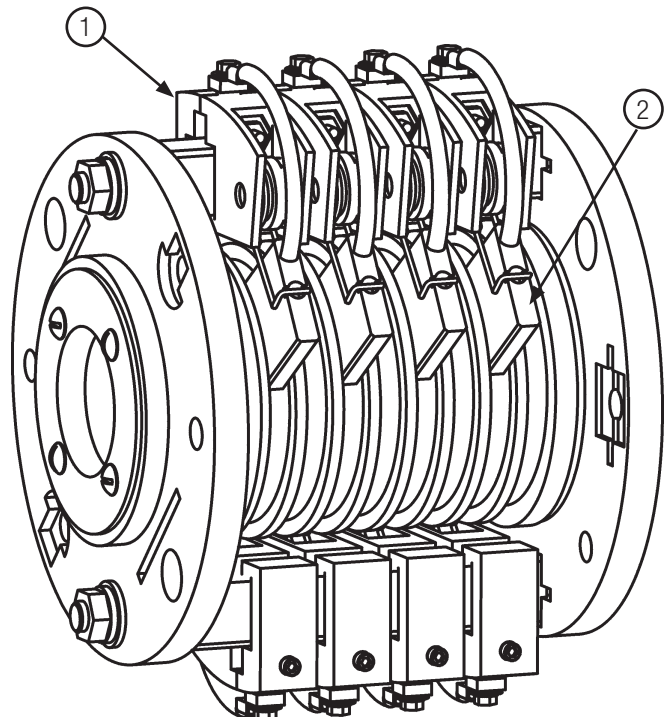
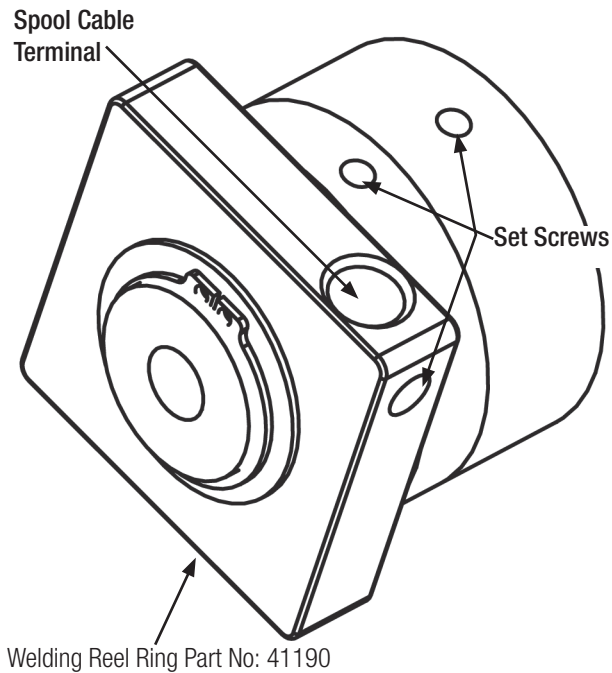

Typical R Series Slip Ring (in this example RA-C08)

# SECTION 7 - REPLACEMENT PARTS

## 7.1 Reel Part Description

### 1900 & 2400 Series Cable Reel

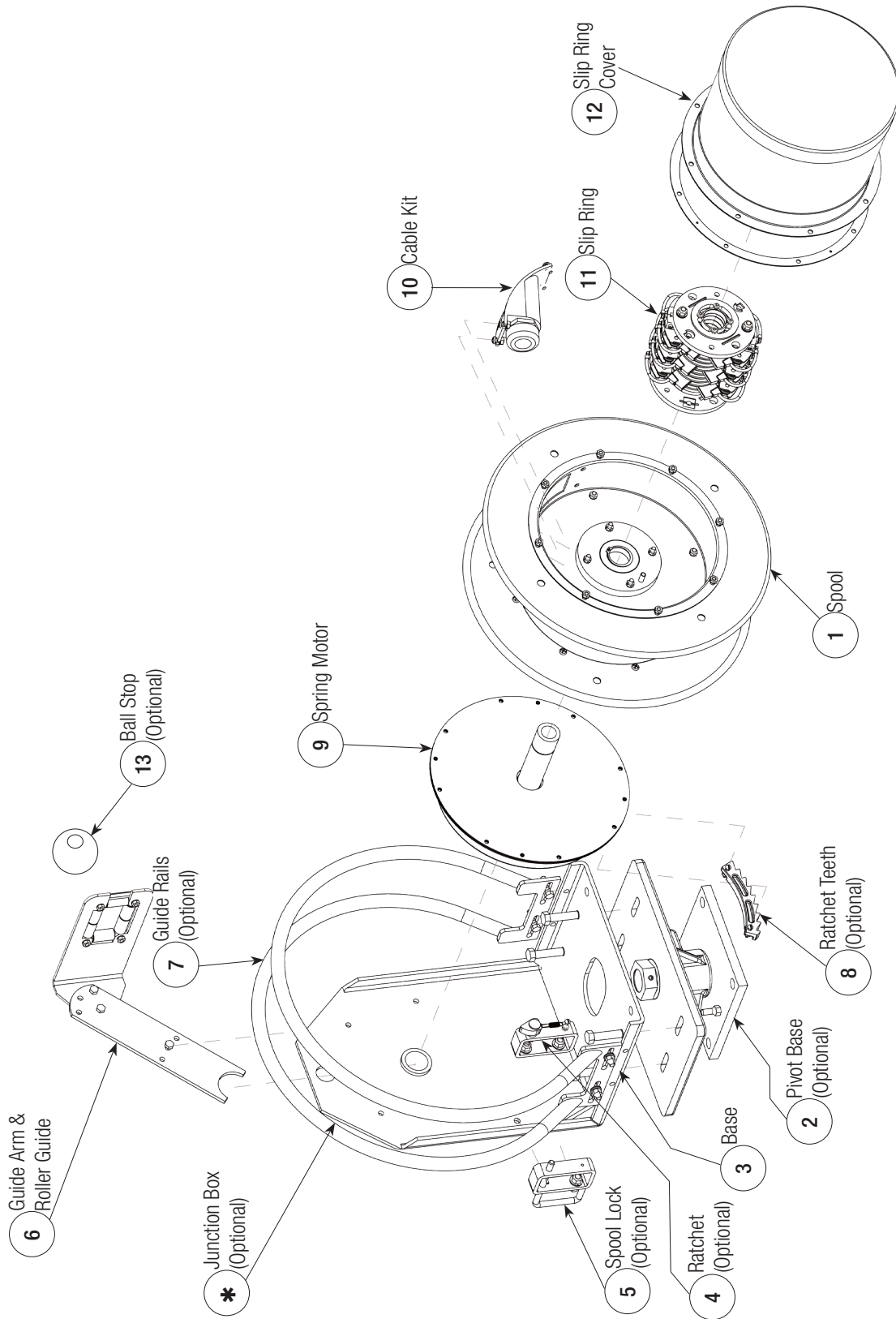

\* Junction Box Not Shown

# SECTION 7 - REPLACEMENT PARTS

## 7.2 Power Reel Part Descriptions

### 7.2.1 PowerReel Standard Parts - ie. 192121005011

1	<b>Spool Assembly</b>								2	
	Guide Rails	40212A	40212AA	40212B			40212BB		<b>Pivot Base</b> 40274	
7	Base Assembly	40200			40203					
	Range Diameter	19.00			24.00					
3	Drum Diameter	12.00	12.00	17.00	18.50*	12.00	17.00	18.50	12N	
	Drum Widths	5.10	7.70	5.10	5.10	5.10	7.70	7.70		
	Spool Assy P/N	40252-K	40253-K	40254-K	40254A-K	40254B-K	40255-K	40255A-K		40255B-K
	<b>Letter Code</b>	<b>E</b>	<b>F</b>	<b>G</b>	<b>H</b>	<b>J</b>	<b>K</b>	<b>L</b>		<b>M</b>

**Series Designation** PR [P] [E] [ES] [A] [D] [C] 08

<b>Roller Guides</b>	Spool Assy	+	Spring Motor	=	Roller Guide #
	E		E, ES, EP L, LS, LP		40258-K
	G, H, J		E, ES, EP L, LS, LP		40258A-K
	E		F, FS, FP		40258B-K
	G, H, J		F, FS, FP		40258C-K
	F		E, ES, EP L, LS, LP		40257-K
	K, L, M		E, ES, EP L, LS, LP		40257A-K
	F		F, FS, FP		40257B-K
	K, L, M		F, FS, FP		40257C-K

<b>Cable Kits</b>	A	101054-K	0.31 - 0.56	1.00" NPT
	B	101055-K	0.50 - 0.75	1.00" NPT
	C	101056-K	0.70 - 0.95	1.00" NPT
	D	101057-K	0.875 - 1.00	1.25" NPT
	E	101058-K	1.065 - 1.20	1.25" NPT
	F	101059-K	1.156 - 1.31	1.50" NPT
	G	101060-K	1.281 - 1.53	1.50" NPT

<b>Double Brushed (if present)</b>	<b>AMP/ VOLT Rating</b>	<b>No. of COND.</b>
------------------------------------	-------------------------	---------------------

<b>Slip Rings</b>	<b>R Series Slip Ring Components</b>					
	P/N	Description			Volts	
	RA-D03-PR	35	Amp	3	Conductor	600
	RA-D04-PR	35	Amp	4	Conductor	600
	RA-C06-PR	35	Amp	6	Conductor	250
	RA-C08-PR	35	Amp	8	Conductor	250
	RA-C10-PR	35	Amp	10	Conductor	250
	RA-C12-PR	35	Amp	12	Conductor	250
	RA-C14-PR	35	Amp	14	Conductor	250
	RA-C16-PR	35	Amp	16	Conductor	250
	RA-C20-PR	35	Amp	20	Conductor	250
	RA-C24-PR	35	Amp	24	Conductor	250
	RA-C30-PR	35	Amp	30	Conductor	250
	RA-E02-PR	75	Amp	2	Conductor	600
RA-E04-PR	75	Amp	4	Conductor	600	
RA-F02-PR	110	Amp	2	Conductor	600	
RA-F04-PR	110	Amp	4	Conductor	600	
RA-G02-PR	150	Amp	2	Conductor	600	
RA-G04-PR	150	Amp	4	Conductor	600	

<b>Ratchets &amp; Locks</b>	<b>Spring Assembly</b>		<b>Ratchet Assembly</b>	<b>Spool Lock Assembly</b>	<b>Ratchet Teeth</b>
	L = 1 Spring	= 40250-3K	40251A	40260A	40251C
	LS = 2 / Series	= 40249-3K			
	LP = 2 / Parallel	= 40248-3K			
	E = 1 Spring	= 40250-1K			
	ES = 2 / Series	= 40249-1K			
	EP = 2 / Parallel	= 40248-1K			
	F = 1 Spring	= 40277-K	40251B	40260B	
FS = 2 / Series	= 40276-K				
FP = 2 / Parallel	= 40275-K				

9 4 5 8

13 **Ball Stop**  
533328-K

* <b>Junction Box (Black)</b>		1.00" NPT (0.31" - 0.95") O.D.	1.25" NPT (0.875" - 1.2") O.D.	1.5" NPT (1.156" - 1.5") O.D.
	NEMA 4 with 4 Cond. 16-8 AWG	40923	-	-
	NEMA 4 with 4 Cond. 6-2 AWG	-	40924	-
	NEMA 4 with 12 Cond.	40925A	40925B	-
	NEMA 4 with 24 Cond.	40926A	40926B	40926C
	NEMA 4 with 30 Cond.	-	40927B	40927C

<b>Covers</b>	<b>5.1 Drum (E, G, H, &amp; J)</b>	<b>7.7 Drum (F, K, L, &amp; M)</b>	<b>Cover #</b>
		D03, D04, C06, E02	2.63" P/N 40231-K
	D03, D04, C06, C08, E02, E03, E04	C08, C10, C12, E03, E04, F02, G02	5.25" P/N 40232-K
	C10, C12, C14, DA20, F02, G02	C14, C16, DA20, F03, G03	8.25" P/N 40267-K
	C16, C20, DA30, F03, F04, G04	C20, C24, DA30, F04, G04	10.50" P/N 40268-K
	C24	C30	12.50" P/N 40269-K

# SECTION 7 - REPLACEMENT PARTS

## 7.3 GafferReel Part Descriptions (Theatre)

### 7.3.1 GafferReel Standard Parts - ie. 192121005011B

**1** **Spool Assembly**

Guide Rails	40212A-BLK	40212AA-BLK	40212B-BLK			40212BB-BLK		
Base Assembly	40200PB			40203PB				
Range Diameter	19.00			24.00				
Drum Diameter	12.00		12.00	17.00	18.50"	12.00	17.00	18.50
Drum Widths	5.10	7.70	5.10	5.10	5.10	7.70	7.70	7.70
Spool Assy P/N	40252-BLK	40253-BLK	40254-BLK	40254A-BLK	40254B-BLK	40255-BLK	40255A-BLK	40255B-BLK
<b>Letter Code</b>	<b>E</b>	<b>F</b>	<b>G</b>	<b>H</b>	<b>J</b>	<b>K</b>	<b>L</b>	<b>M</b>

**2** **Pivot Base**

40274
-------

**7**

**3**

**Series Designation**

**GR** [ P ] [ E ] [ ES ] [ A ] [ D ] [ D ] [ 08 ]

**12N**

**6**

Spool Assy	+	Spring Motor	=	Roller Guide #
E		E, ES, EP L, LS, LP		40258-PB
G, H, J		E, ES, EP L, LS, LP		40258A-PB
E, G, H, J		F, FS, FP		40258C-PB
F		E, ES, EP L, LS, LP		40257-PB
K, L, M		E, ES, EP L, LS, LP		40257A-PB
F, K, L, M		F, FS, FP		40257C-PB

**10**

Cable Kits	P/N	Length	Thread
<b>A</b>	101054-K	0.31 - 0.56	1.00" NPT
<b>B</b>	101055-K	0.50 - 0.75	1.00" NPT
<b>C</b>	101056-K	0.70 - 0.95	1.00" NPT
<b>D</b>	101057-K	0.875 - 1.00	1.25" NPT
<b>E</b>	101058-K	1.065 - 1.20	1.25" NPT
<b>F</b>	101059-K	1.156 - 1.31	1.50" NPT
<b>G</b>	101060-K	1.281 - 1.53	1.50" NPT

Double Brushed (if present)	AMP/VOLT Rating	No. of COND.
-----------------------------	-----------------	--------------

**9**

Spring Assembly	=	P/N
L = 1 Spring	=	40250-3-BLK
LS = 2 / Series	=	40249-3-BLK
LP = 2 / Parallel	=	40248-3-BLK
E = 1 Spring	=	40250-1-BLK
ES = 2 / Series	=	40249-1-BLK
EP = 2 / Parallel	=	40248-1-BLK
F = 1 Spring	=	40277-K
FS = 2 / Series	=	40276-K
FP = 2 / Parallel	=	40275-K

**4**

Ratchet Assembly	P/N
40251A-K	40260A-K
40251B-K	40260B-K

**5**

Spool Lock Assembly	P/N
40260A-K	40260B-K
40260A-K	40251C-K

**8**

Ratchet Teeth	P/N
40251C-K	40260B-K

**11**

R Series Slip Ring Components		
P/N	Description	Volts
RA-D03-PR	35 Amp 3 Conductor	600
RA-D04-PR	35 Amp 4 Conductor	600
RA-D06-PR	35 Amp 6 Conductor	600
RA-D08-PR	35 Amp 8 Conductor	600
RA-D10-PR	35 Amp 10 Conductor	600
RA-D12-PR	35 Amp 12 Conductor	600
RA-D14-PR	35 Amp 14 Conductor	600
RA-D16-PR	35 Amp 16 Conductor	600
RA-D20-PR	35 Amp 20 Conductor	600
RA-D24-PR	35 Amp 24 Conductor	600
RA-D30-PR	35 Amp 30 Conductor	600
RA-E02-PR	75 Amp 2 Conductor	600
RA-E04-PR	75 Amp 4 Conductor	600
RA-F02-PR	110 Amp 2 Conductor	600
RA-F04-PR	110 Amp 4 Conductor	600
RA-G02-PR	150 Amp 2 Conductor	600
RA-G04-PR	150 Amp 4 Conductor	600

**12N**

**12**

	5.1 Drum (E, G, H, & J)	7.7 Drum (F, K, L, & M)	Cover #
		D03, D04, E02	2.63" P/N 40231-PB
D03, D04, D05, E02, E03, E04		D05, D06, D07, D08, E03, E04, E05, F02, G02	5.25" P/N 40232-PB
D06, D07, D08, E05, F02, G02		D09, D10, F04, G04	8.25" P/N 40267-PB
D09, D10, D12, D14, F03, F04, G03, G04		D14, D16, F04, G04	10.50" P/N 40268-PB
	D16	D20	12.50" P/N 40269-PB
		D24	16" P/N 42233-PB
	D20	D30	18" P/N 45652-PB

**\***

Junction Box (Black)	1.00" NPT (0.31" - 0.95") O.D.	1.25" NPT (0.875" - 1.2") O.D.	1.5" NPT (1.156" - 1.5") O.D.
NEMA 4 with 4 Cond. 16-8 AWG	40923	-	-
NEMA 4 with 4 Cond. 6-2 AWG	-	40924	-
NEMA 4 with 12 Cond.	40925A	40925B	-
NEMA 4 with 24 Cond.	40926A	40926B	40926C
NEMA 4 with 30 Cond.	-	40927B	40927C

## SECTION 8 - TROUBLESHOOTING

PROBLEM	POSSIBLE CAUSE	SOLUTION
Reel will not retract cable but has some tension.	<ol style="list-style-type: none"> <li>1) Improper pretension</li> <li>2) Incorrect reel for application (lift vs. stretch).</li> <li>3) Improper cable or cable length installed.</li> </ol>	<ol style="list-style-type: none"> <li>1) See Tension Adjustment section.</li> <li>2) Quantify application vs. reel selection.</li> <li>3) Install correct cable type and length.</li> </ol>
Reel does not have spring tension.	<ol style="list-style-type: none"> <li>1) Broken spring. *Quantify application to prevent reoccurrence.</li> </ol>	<ol style="list-style-type: none"> <li>1) Replace spring motor.</li> </ol>
Ratchet will not engage.	<ol style="list-style-type: none"> <li>1) Broken ratchet pawl spring.</li> </ol>	<ol style="list-style-type: none"> <li>1) Replace ratchet pawl spring.</li> </ol>
Ratchet will not disengage.	<ol style="list-style-type: none"> <li>1) Over-extension of reel.</li> </ol>	<ol style="list-style-type: none"> <li>1) Manually rotate reel spool to disengage ratchet. To prevent lockup, two wraps of cable should remain on spool at all times.</li> </ol>
Cable wraps improperly (uneven wrapping, wraps above or jumps flange).	<ol style="list-style-type: none"> <li>1) Reel mounting not level.</li> <li>2) Cable retraction rate too high.</li> <li>3) Cable guide out of adjustment.</li> </ol>	<ol style="list-style-type: none"> <li>1) Mount reel on level surface.</li> <li>2) Maintain steady retraction rate.</li> <li>3) Properly adjust cable guide.</li> </ol>
Cable twisting or knotting.	<ol style="list-style-type: none"> <li>1) Improperly installed cable.</li> <li>2) Cable rubbing on or bending around fixed object.</li> <li>3) Excessive spring tension.</li> <li>4) Inadequate anchoring of cable.</li> </ol>	<ol style="list-style-type: none"> <li>1) See Cable Install section on IOM.</li> <li>2) Check roller guide for function and cable pay out path.</li> <li>3) Quantify application vs. reel selection. Also check pretension.</li> <li>4) Adjust anchoring method. ie. add strain relief.</li> </ol>
Open or intermittent circuit.	<ol style="list-style-type: none"> <li>1) Inadequate connection.</li> <li>2) Brush loses contact with slip ring.</li> <li>3) Cable defective.</li> </ol>	<ol style="list-style-type: none"> <li>1) Check all termination points.</li> <li>2) Check brush wear, spring tension &amp; alignment.</li> <li>3) Perform continuity check on cable.</li> </ol>
Circuit trips and/or Pitted burned rings or brushes.	<ol style="list-style-type: none"> <li>1) Inadequate amp rating of reel.</li> </ol>	<ol style="list-style-type: none"> <li>1) Quantify application requirements vs. reel &amp; cable rating.</li> </ol>
Circuit arcing	<ol style="list-style-type: none"> <li>1) Amp or voltage above rating of reel.</li> <li>2) Excessive carbon dust accumulation.</li> <li>3) Water or moisture in slip ring.</li> </ol>	<ol style="list-style-type: none"> <li>1) Quantify application requirements vs. reel &amp; cable rating.</li> <li>2) Clean dust from inside slip ring.</li> <li>3) Check gasket seal.</li> <li>4) Replace brush spring.</li> </ol>



## NOTES

# www.conductix.us

## USA / LATIN AMERICA

10102 F Street  
Omaha, NE 68127

Customer Support  
Phone +1-800-521-4888

Phone +1-402-339-9300  
Fax +1-402-339-9627

info.us@conductix.com  
latinamerica@conductix.com

## CANADA

1435 Norjohn Court  
Unit 5  
Burlington, ON L7L 0E6

Customer Support  
Phone +1-800-667-2487

Phone +1-450-565-9900  
Fax +1-450-951-8591

info.ca@conductix.com

## MÉXICO

Calle Treviño 983-C  
Zona Centro  
Apodaca, NL México 66600

Customer Support  
Phone (+52 81) 1090 9519  
(+52 81) 1090 9025  
(+52 81) 1090 9013

Fax (+52 81) 1090 9014

info.mx@conductix.com

## BRAZIL

Rua Dois, 493  
Itu, São Paulo, Brasil  
CEP: 13312-820

Customer Support  
Phone (+55 11) 4813 7330

Fax (+55 11) 4813 7330

info.br@conductix.com

Contact us for our Global Sales Offices

