

Hevi-Bar I Manual for Port Applications 1000A, 1500A, 2000A 5kV System

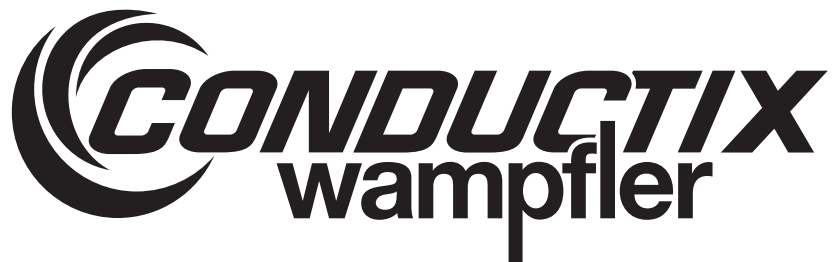
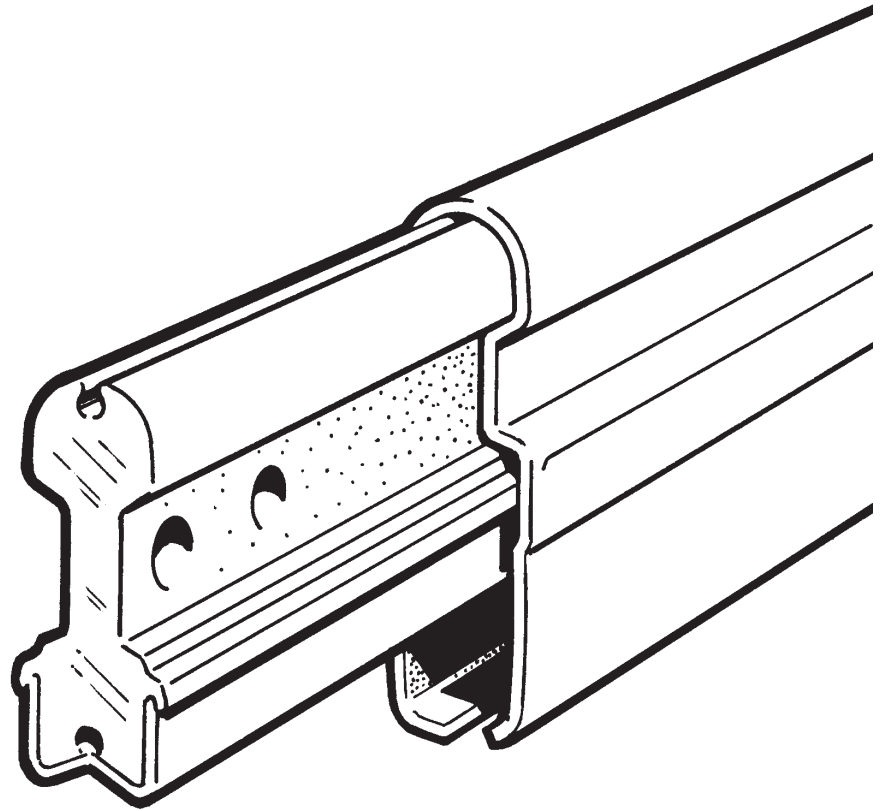

The technical data and images which appear in this manual are for informational purposes only. **NO WARRANTIES, EXPRESS OR IMPLIED, INCLUDING WARRANTIES OF MERCHANTABILITY OR FITNESS FOR A PARTICULAR PURPOSE, ARE CREATED BY THE DESCRIPTIONS AND DEPICTIONS OF THE PRODUCTS SHOWN IN THIS MANUAL.** Conductix makes no warranty (and assumes no liability) as to function of equipment or operation of systems built according to customer design or of the ability of any of its products to interface, operate or function with any portions of customer systems not provided by Conductix.

Seller agrees to repair or exchange the goods sold hereunder necessitated by reason of defective workmanship and material discovered and reported to Seller within one year after shipment of such goods to Buyer.

Except where the nature of the defect is such that it is appropriate, in Seller's judgment, to effect repairs on site, Seller's obligation hereunder to remedy defects shall be limited to repairing or replacing (at Seller's option) FOB point of original shipment by Seller, any part returned to Seller at the risk and cost of Buyer. Defective parts replaced by Seller shall become the property of Seller.

Seller shall only be obligated to make such repair or replacement if the goods have been used by Buyer only in service recommended by Seller and altered only as authorized by Seller. Seller is not responsible for defects which arise from improper installation, neglect, or improper use or from normal wear and tear.

Additionally, Seller's obligation shall be limited by the manufacturer's warranty (and is not further warranted by Seller) for all parts procured from others according to published data, specifications or performance information not designed by or for Seller.

Seller further agrees to replace or at Seller's option to provide a refund of the sales price of any goods that do not conform to applicable specifications or which differ from that agreed to be supplied which non-conformity is discovered and forthwith reported to Seller within thirty (30) days after shipment to the Buyer. Seller's obligation to replace or refund the purchase price for non-conforming goods shall arise once Buyer returns such goods FOB point of original shipment by Seller at the risk and cost of Buyer. Goods replaced by Seller shall become the property of Seller.

There is no guarantee or warranty as to anything made or sold by Seller, or any services performed, except as to title and freedom from encumbrances and, except as herein expressly stated and particularly, and without limiting the foregoing, **there is no guarantee or warranty, express or implied, of merchantability or of fitness for any particular purpose or against claim of infringement or the like.**

Seller makes no warranty (and assumes no liability) as to function of equipment or operation of systems built to Buyer's design or of the ability of any goods to interface, operate or function with any portions of Buyer's system not provided by Seller.

Seller's liability on any claim, whether in contract, tort (including negligence), or otherwise, for any loss or damage arising out of, connected with, or resulting from the manufacture, sale, delivery, resale, repair, replacement or use of any products or services shall in no case exceed the price paid for the product or services or any part thereof which give rise to the claim. In no event shall Seller be liable for consequential, special, incidental or other damages, nor shall Seller be liable in respect of personal injury or damage to property not the subject matter hereof unless attributable to gross misconduct of Seller, which shall mean an act or omission by Seller demonstrating reckless disregard of the foreseeable consequences thereof.

Seller is not responsible for incorrect choice of models or where products are used in excess of their rated and recommended capacities and design functions or under abnormal conditions. Seller assumes no liability for loss of time, damage or injuries to property or persons resulting from the use of Seller's products. Buyer shall hold Seller harmless from all liability, claims, suits and expenses in connection with loss or damage resulting from operation of products or utilization of services, respectively, of Seller and shall defend any suit or action which might arise there from in Buyer's name - provided that Seller shall have the right to elect to defend any such suit or action for the account of Buyer. The foregoing shall be the exclusive remedies of the Buyer and all persons and entitles claiming through the Buyer.

- 1.0 Application Scope
- 2.0 Safety Procedures
- 3.0 Project Familiarization
- 4.0 Suggested Tools and Equipment
- 5.0 Unloading of Material at the Job Site
- 6.0 Installation Considerations
- 7.0 Conductor Bas Bar
- 8.0 Conductor Bus Bar Installation
- 9.0 Cutting of Bus Bar
- 10.0 Bolted Splice Installation and Assembly
- 11.0 End Cover Installation
- 12.0 Hanger Clamp Assembly
- 13.0 Hanger Bracket Installation
- 14.0 Powerfeed Bus Bar Installation to Power Rail
- 15.0 Expansion Section
- 16.0 Power Interrupting Isolation/Transition
- 17.0 Power Interrupting Section-Interphase Barrier
- 18.0 Collector Setup and Installation
- 19.0 Grounding of System
- 20.0 Minimum Clearance-Component to Hanger Bracket
- 21.0 Preventative Maintenance

1.0 Application Scope

- 1.0.1 Port projects are typically medium voltage systems in an underground concrete trench. The trench is covered with plate steel.
- 1.0.2 Power is supplied to the cranes through a three conductor power rail system. The three conductor rails use Conductix's Hevi-bar I conductor bus bar for a 1000, 1500, or 2000 Amperes at 5kV. System may include straight bar, powerfeeds, bar splices, expansion sections, and power interrupting sections consisting of an isolation and interphase barrier section for each conductor rail.
- 1.0.3 Each rail utilizes aluminum as the conductor and a stainless steel running surface for the contact shoe. The conductor rails are covered on three sides with a PVC cover to withstand the voltage of the system.
- 1.0.4 The rails are mounted to steel hanger brackets using insulated hangers. The steel hanger brackets, spaced at 5 to 10-foot intervals (dependant on fault force requirements for the system), are attached to a trench wall. The rails are designed to slide in the hangers to allow for thermal expansion.

2.0 Safety Procedures

- 2.0.1 As in any work site, strict compliance of safety procedures and regulations shall be observed. Before working on power or control rail, **POWER MUST BE OFF!** System **MUST be locked out and tagged out!** Use an appropriate tester to check for voltage **BEFORE any work is started!**

3.0 Project Familiarization

- 3.0.1 All personnel working on the power rail installation should be familiar with the components and layout details.
- 3.0.2 The Installation crews must follow Conductix's layout drawings as approved by Conductix and other designated parties.
- 3.0.3 The main component drawings are identified on page 4 of this document in the drawing list and are referenced throughout this installation manual. A complete set of installation reference drawings is attached to this manual in Appendix A.

4.0 Suggested Tools and Equipment

- 4.0.1 The installation process requires thorough familiarity with the product and guide way system requirements and the use of proper tools and equipment.

4.0 Suggested Tools and Equipment

4.1 Recommended Tools

	Description	Purpose
1	1/2" Variable speed electric drill	Drilling necessary holes
2	1/2" and 3/8" Calibrated torque wrenches	Proper tightening of hardware
3	3/8" Sockets, 1/4" to 1"	Tightening component hardware
4	Electric heat gun	Heating of heat shrink tubing
5	3M Scotch-Brite pads	Removing oxidation from bus bar
6	Rubber or dead-blow mallet	Move bus bar in hangers
7	30 ft and 100 ft measuring tapes	Mark correct position of accessories
8	8 inch flat files, fine and medium	Smooth ends of cut bus bar
9	6 inch rat tail files	Smooth ends of cut bus bar
10	Combination wrenches 1/4" to 1"	Tightening component hardware
11	Sockets 1/2" drive, 1/4" to 1"	Tightening component hardware
12	Megger, 1000/5000 VDC	Check isolation effectiveness
13	Multi-Tester	Check continuity at splice joints
14	Screw drivers	Component assembly
15	Thermometer	Measure bus bar temperature
16	Portable electric bandsaw (Port-A-Band)	Cutting bus bar
17	Hacksaw or cutoff saw	Cutting bus bar
18	Dremel tool with ball end mill	Smooth ends of cut bus bar
19	C-Clamps 10" (6)	For expansion setting
20	General electrician tools	
21	Crane to unload trucks and move material	
22	20 ft. spreader bar	Unloading material
23	Anti-seize lubricant	For all stainless steel hardware
24	Tri-square	Checking ends of cut bar

5.0 Unloading of Material at the Job Site

- 5.0.1 All conductor bars and associated major components are shipped in wooden crates up to approximately 31' in length. Each may weigh over 1,000 lbs. per box and possibly more when the crates are stacked. These crates must be handled carefully and off-loaded from the trailer with a forklift or crane using an appropriate spreader bar. When handling crated or single pieces of 30 feet or longer, a 12-foot spreader with two slings at each end must be used. If slings only are to be used, the sling length must be positioned so the enclosed angle is less than or equal to 60 degrees.
- 5.0.2 The contents marked on the side of each wooden crate shall be checked against the accompanying packing list. Any discrepancy or damaged items shall be recorded and photographed. The appropriate site manager must then be notified.
- 5.0.3 Safety in handling all components must be strictly observed and all personnel in the vicinity must wear hard hats at all times.
- 5.0.4 DO NOT REMOVE SHIPPING SUPPORT FROM THE EXPANSION SECTIONS UNTIL THE UNITS HAVE BEEN INSTALLED ON THE GUIDEWAY.

6.0 Installation Considerations

- 6.0.1 To avoid problems during installation, the installer's personnel must become familiar with the notes on the Assembly Drawings. The Assembly Drawings serve to identify the components and will also specify the method of field assembly (if required) and all torque values for all fasteners. In the event of a conflict or question over torque values between this document and the assembly drawings, the assembly drawings will take precedence.
- 6.0.2 A system layout provided by Conductix provides a reference to the location and spacing of the components on the system. Field verification of components by the installer is required.

7.0 Conductor Bus Bar

- 7.0.1 The system consists of the standard 30' lengths conductor bar used throughout the system. Shorter bar sections may also be used throughout the system (as shown on the system layout).
- 7.0.2 The middle conductor bar cover in the system is noted with a "Danger 5kV-Do Not Touch" or "Danger High Voltage-Do Not Touch" marking spaced evenly at 4 feet, it should be noted that it is used as the middle bar only.
- 7.0.3 At either end of the system, installer will need to field cut to suit, as indicated on the layout, from a 30' section of conductor bar. Length of cut piece must be field verified.

8.0 Conductor Bus Bar Installation

- 8.0.1 Refer to the Conductix layout drawings before installing any components on the trench wall. The hanger brackets must be mounted on the trench wall before installation of the bar and aligned accordingly.
- 8.0.2 Note to the Installer: Determine if the minimum clearance distances between the components and hanger brackets can be achieved without cutting the rail (Refer to Section 18 on minimum clearances).
- 8.0.3 Start the rail installation at either end from the field cut bar location as indicated on the layout drawing and work towards the expansion. Use 30' bar lengths until the expansion section is to be installed. Continue with the 30' standard bar length sections until the next expansion. Set first expansion section (see section 15) and torque hangers at anchor locations, refer to layout drawing.
- 8.0.4 Be sure the two adjoining rails are butted together before connecting the splice connection to the two rails. If necessary, carefully tap the far end of the rail with a rubber mallet to butt it against the other rail. Do not tap too hard. It is possible to inadvertently close and expansion of the end of a bar is struck with a lot of force.
- 8.0.5 Follow the Bolted Splice Installation Instructions as detailed in Section 10.0. After installing the splice connection and torque properly. Tighten the nuts on the hanger clamp until .02-.05 inch clearance remains between the hanger clamp and the conductor bar. At anchor locations, torque nuts on the hanger clamp to 60 in.-lbs.
- 8.0.6 Repeat the above procedures for subsequent conductor bar installation per the layout drawings. Ensure that the minimum clearances between components and brackets are maintained throughout the installation (Section 18).

9.0 Cutting of Bus Bar

9.1 Cutting Rules

- 9.1.1 Slide the PVC cover out of the way of cutting operation or remove it. Cut rail to the desired length using a band saw. Ensure the rail end is square (90° cut) and fully deburred using the round and flat files. The adjoining rail ends must butt together at the splice joints.
- 9.1.2 **NOTE:** A 45° chamfer must be put on the end of the stainless steel cap on the bus bar running surface (at end of bus bar and any cut bus bar) for a smooth transition of the collector shoe.
- 9.1.3 For bus bar cuts, the cover should be cut appropriately depending upon its location, refer to drawings showing cover cutback of 6 inches at splices and isolation sections.
- 9.1.4 After cutting of the PVC cover, remove the plastic burrs with a pocket or utility knife. Also, at ends of the cover clip the corners at a 45° angle as shown on the bar drawing, refer to Appendix A.

10.0 Bolted Splice Installation and Assembly

- 10.0.1 The bolted splice assembly consists of splice plates, hardware and overlap covers as a kit.
- 10.0.2 Clean the area to be joined on the conductor and splice plate. This can be done with a clean 3M Scotch Brite Pad (the purpose is to expose non-oxidized aluminum for a good electrical contact).
- 10.0.3 Immediately spread a liberal quantity of EJC-2 compound evenly over the cleaned surfaces (1-8 oz. tube is good for approximately 30-50 joints).
- 10.0.4 Repeat steps 10.0.1 to 10.0.3 on other side of conductor and the contact side of both splice plates.
- 10.0.5 Place the splice plate in position and add a small amount of anti-seize to bolts before tightening (Refer to Ref. Drawing for Splice Bar Assembly in Appendix A for further reference). Torque bolts to the values indicated on the splice drawing.
- 10.0.6 Install overlap cover over splice assembly making sure the slots in the cover lines up with the splice hardware, this will prevent the cover from sliding. Bolt the two halves together once in place. Verify that the overlap cover is secured to the hardware and will not move along the conductor bar.
- 10.0.7 **NOTE:** It is recommended that after butting the two adjoining bars together and splicing them, to snap on the splice cutout cover for ease of installation.

11.0 End Cover Installation

- 11.0.1 End cover installation is at both ends of the runway.
- 11.0.2 Install bar cover, with the overlap end cover, at the end of bar. The overlap cover will extend past the bar cover to accommodate any possible gap between the adjoining conductor bar covers due to thermal expansion; refer to the end cover drawing.
- 11.0.3 Install hanger clamp as shown on the drawing and torque bolts to 60 in.-lbs.

12.0 Hanger Clamp Assembly

- 12.0.1 The hanger clamp assembly consists of a 5kV insulator attached to the hanger clamp that holds the conductor bar. The insulator prevents electrical creepage from the conductor bar to the hanger bracket.
- 12.0.2 Install and torque the hanger clamp to the bottom of the hanger bracket as shown on the insulated hanger drawing. The cross-bolts should be loose or not installed yet in order to run the conductor bar through the hangers.
- 12.0.3 All hangers are to be sliding tight (tighten until .02-.05 inch clearance remains between hanger clamp and the conductor bar), except at anchor locations. At anchor locations, nuts on the hanger are to be torqued to 60 in.-lbs. Refer to the layout drawing, if provided, for anchor locations..
- 12.0.4 There must be three hanger clamps for every hanger bracket.

13.0 Hanger Bracket Installation

- 13.0.1 There are several different types of hanger brackets used by our systems.
- 13.0.2 Installation of the brackets should match the layout drawing as close as possible. It is understood that some field adjustments will be required. Please keep in mind, if the position of one bracket is adjusted, don't shift the position of the next bracket.
- 13.0.3 In order to mount the hanger brackets, a welding fixture should be used.
- 13.0.4 Install hanger bracket onto the welding fixture and secure with wing nuts in the trench.
- 13.0.5 Adjust fixture and bracket to make flush with the trench wall, level, and aligned with adjacent brackets.
- 13.0.6 Once hanger bracket is positioned, weld the top part of the hanger bracket to the existing imbedded angle iron in the trench wall. Make sure the fillet weld is on all sides of the top part of the hanger bracket.
- 13.0.7 Once secure, loosen the wing nuts from the welding fixture and remove the fixture. The welding fixture can then be used on the next hanger bracket.
- 13.0.8 Make sure hanger brackets are installed correctly as shown on the layout drawing. The hanger brackets base has one side open for debris and water run out. This should be faced away from the trench wall.

14.0 Powerfeed Installation to Power Rail

- 14.0.1 Powerfeed installation requires conductor bar sections with a powerfeed lug plate or 2-piece clamp. Powerfeed cables should be non-shielded, extra-flexible no larger than 535 MCM. Feed cable weight must be supported by means other than Conductix bus.
- 14.0.2 All necessary hardware and overlap covers are supplied with powerfeed bars.
- 14.0.3 Use cleaning pads to remove all debris, oil and dirt from the parts.
- 14.0.4 Install powerfeed cables: Clean all mating surfaces with 3M Scotch Brite Pads, apply a small amount of EJC to cleaned surfaces, assemble cables to lugs on bus, and add hardware. Add a small amount of anti-seize to hardware and torque to specification that is being used on this connection.
- 14.0.5 **NOTE:** Before landing cables on the powerfeed bus bar, megger or high pot power cables (done by others) to ensure acceptable cables.

15.0 Expansion Section

- 15.0.1 A 20' long expansion assembly is designed to accommodate the thermal expansion and contraction of the power rails. The expansion section consists of a slider mechanism that ensures continuous travel of the collector shoe as it passes through the section.
- 15.0.2 The expansion section is spliced to the conducting bar using the same bolted splice assembly used to splice the bar sections to one another. The layout drawing will indicate the correct location of the expansion sections.
- 15.0.3 The expansion sections are to be installed as the rails are installed. From an anchor point, install the conductor rail to the next expansion location, install the expansion section and resume installation of rail to the next anchor point. At the expansion location, determine whether the rail already installed up to that point should be cut, or if the rail on the expansion section must be cut, or both. From the layout drawing it can be seen that cutting should not occur for the system. Any cutting will require holes to be re-drilled in the bar at the same location as what it would be to splice two bars together.
- 15.0.4 Before installing the expansion section, the expansion gap must now be set according to the ambient temperature. Ensure the rails have reached ambient temperature. Measure the temperature of the installed rail with the contact thermometer at least 2 places on one bar to verify accurate reading then set the gap of the expansion joint according to the chart on the expansion drawing.
- 15.0.5 It is important to install the expansion section and set the anchor before there is a significant temperature change in the installed bar sections.
Note: Recheck the expansion gap once again before torquing the second anchor clamp.

16.0 Power Interrupting Isolation Section/Transition

- 16.0.1 This section entails the isolation section and the interphase barrier section.
- 16.0.2 The isolation section is a 1.0' to 2.0' section of non-conductive material spaced per NEC Code between two live parts.
- 16.0.3 The isolation section can be spliced similar to splicing two conductor bars together. Note the cover installation is also similar to the bolted splice section for two bars.
- 16.0.4 After splice plate is torque and installed and the splice cutout cover and overlap cover installed, install a strong back for supporting the isolation section. The hanger clamps should be installed similar as indicated before in the hanger clamp assembly section.

17.0 Power Interrupting Section-Interphase Barrier

- 17.0.1 An interphase barrier may be required between the conductor bars for electrical considerations, spark arcing from bar to bar. This is used only for the power interrupting section to prevent arcing across the bar.
- 17.0.2 Start location of interphase barrier as shown on the layout drawings. The interphase barrier is bolted to the hanger brackets. The installer is to drill and bolt to the plastic angle at the locations of the hanger brackets specified in the layout
- 17.0.3 For additional lengths of the interphase barrier, splice the lengths with the interphase barrier splice kit.
- 17.0.4 Torque interphase barrier connections per the drawing.

18.0 Collector Setup and Installation

- 18.0.1 The collector assembly is a tandem set mounted to a plow provided by customer. The purpose of the collector is collecting the current from the bar in order to power the crane.
- 18.0.2 These collectors are parallelogram devices, which both articulate and swivel. Positive contact with the conductor bar is maintained by spring-loaded arms through 10 inches of vertical travel. Spring pressure (contact force) for the collector is 25 to 30 lbs. through the working range. Exposed metal parts are stainless steel and anodized aluminum.
- 18.0.3 The replaceable contact shoes are mounted in non-conducting cases. Metal parts are grounded to the collector mounting brackets. Flexible leads are furnished to assure free movement and tracking of the collector shoe.
- 18.0.4 Refer to collector drawing as a reference and for setup.

19.0 Grounding of System

- 19.0.1 The purpose of this is to ground the system during maintenance operation.
- 19.0.2 Refer to drawing in Appendix A for grounding setup and layout.
- 19.0.3 Attach clamp halves to grounding rail and run cable to splice connection.
- 19.0.4 Remove a bolt from the splice assembly and tighten both ends of cable as indicated on the drawing.
- 19.0.5 When finished, reinstall components like they were before grounding the system for maintenance purposes.

20.0 Minimum Clearance-Component to Hanger Bracket

- 20.0.1 It must be noted that due to thermal expansion of the bar that the installation of the expansion (35460) be installed correctly. The expansion ends to the nearest hanger assembly allows only 6-7" from either end of the expansion assembly (in its fully open position) due to the temperature change of the bar and the spacing of the hanger brackets.
- 20.0.2 It is essential that no rail components (components attached to the rails that will move as the rails expand and contract) be mounted within 18" (from center of hanger bracket to center of component) from any bracket locations (unless other wise specified in on layout drawing).
- 20.0.3 If any component falls within the guidelines indicated in this section, cutting is not required. Cut rail only when necessary, such as when interference is encountered.
- 20.0.4 Components to be included in this clearance are the following:

21.0 Preventative Maintenance

21.1 Bolted Splice Assemblies - Once a year

- 21.1.1 Check the torque of the bolts for the splice assemblies (do approximately 10%, if wrong continue to check all of them).
- 21.1.2 Check the overlap covers for proper torque on the bolts and overall operation (evaluate covers for any burn marks or other defects).

21.2 Expansion Sections – Once a year

- 21.2.1 Check fingers on expansion for wear.
- 21.2.2 Clean debris out of the fingers with compressed air.

21.3 Isolation Sections – Annually

- 21.3.1 Check for wear.
- 21.3.2 Check for alignment (use a collector shoe and by running it across the joints on the surface – should be a smooth transition).

21.4 Power feeds - Annually

- 21.4.1 Check wear on the feeder cables.
- 21.4.2 Check torque on bolts of cable and bus bar lugs.

21.5 Anchor Points – Check 10%, check all if bad

- 21.5.1 Check torque on anchor tight locations (Torque of 60 in-lbs.).

21.6 Hanger Clamp Assembly – 10% inspection

- 21.6.1 Inspect porcelain insulators for possible cracks.
- 21.6.2 Check torque on support bracket bolts.
- 21.6.3 Check cross-bolts of hanger clamp for sliding tight (.02-.05 inch clearance between the hanger clamp and the conductor bar).

21.7 Collector Assembly – Inspect monthly

- 21.7.1 Verify contact force of collector to conductor bus bar.
- 21.7.2 Check shoes for wear.
- 21.7.3 Check cables for wear, cracks or other defects.
- 21.7.4 Every 6 months do a complete analysis on the collector assembly to be inspected thoroughly (use print as a reference).

Grounding Setup Reference

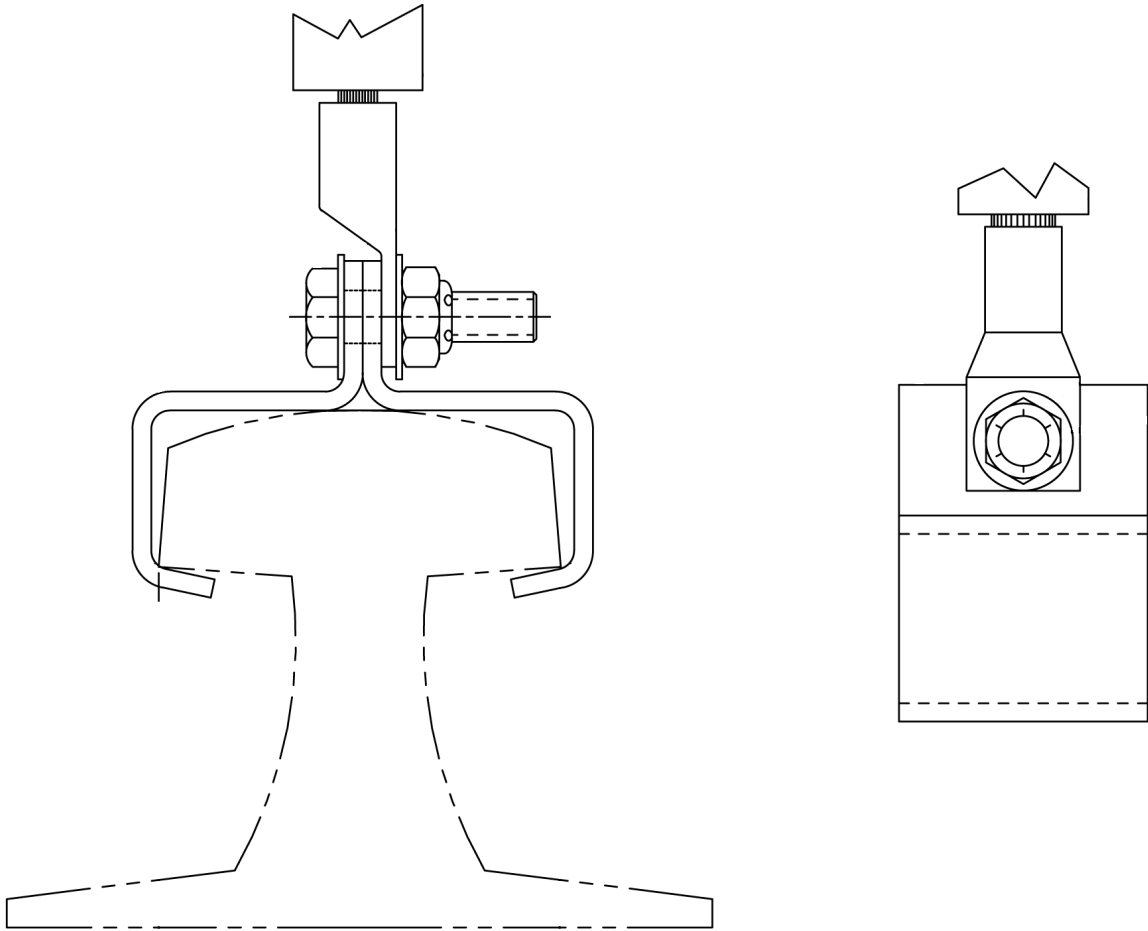
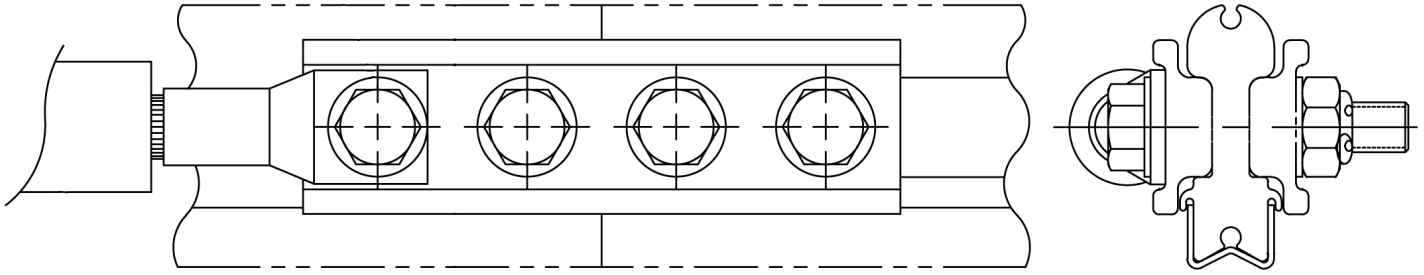

www.conductix.us

USA / LATIN AMERICA

10102 F Street
Omaha, NE 68127

Customer Support

Phone +1-800-521-4888

Phone +1-402-339-9300

Fax +1-402-339-9627

info.us@conductix.com

latinamerica@conductix.com

CANADA

1435 Norjohn Court
Unit 5
Burlington, ON L7L 0E6

Customer Support

Phone +1-800-667-2487

Phone +1-450-565-9900

Fax +1-450-851-8591

info.ca@conductix.com

MÉXICO

Calle Treviño 983-C
Zona Centro
Apodaca, NL México 66600

Customer Support

Phone (+52 81) 1090 9519

(+52 81) 1090 9025

(+52 81) 1090 9013

Fax (+52 81) 1090 9014

info.mx@conductix.com

BRAZIL

Rua Luiz Pionti, 110
Vila Progresso
Itu, São Paulo, Brasil
CEP: 13313-534

Customer Support

Phone (+55 11) 4813 7330

Fax (+55 11) 4813 7357

info.br@conductix.com

Contact us for our Global Sales Offices

