

Saf-T-Bar Conductor Bar

T Series

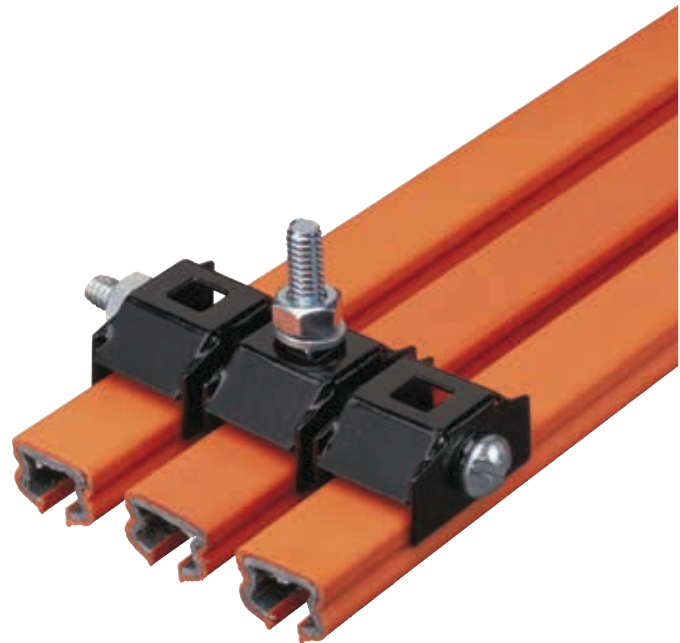

The technical data and images which appear in this manual are for informational purposes only. **NO WARRANTIES, EXPRESS OR IMPLIED, INCLUDING WARRANTIES OF MERCHANTABILITY OR FITNESS FOR A PARTICULAR PURPOSE, ARE CREATED BY THE DESCRIPTIONS AND DEPICTIONS OF THE PRODUCTS SHOWN IN THIS MANUAL.** Conductix makes no warranty (and assumes no liability) as to function of equipment or operation of systems built according to customer design or of the ability of any of its products to interface, operate or function with any portions of customer systems not provided by Conductix.

Seller agrees to repair or exchange the goods sold hereunder necessitated by reason of defective workmanship and material discovered and reported to Seller within one year after shipment of such goods to Buyer.

Except where the nature of the defect is such that it is appropriate, in Seller's judgment, to effect repairs on site, Seller's obligation hereunder to remedy defects shall be limited to repairing or replacing (at Seller's option) FOB point of original shipment by Seller, any part returned to Seller at the risk and cost of Buyer. Defective parts replaced by Seller shall become the property of Seller.

Seller shall only be obligated to make such repair or replacement if the goods have been used by Buyer only in service recommended by Seller and altered only as authorized by Seller. Seller is not responsible for defects which arise from improper installation, neglect, or improper use or from normal wear and tear.

Additionally, Seller's obligation shall be limited by the manufacturer's warranty (and is not further warranted by Seller) for all parts procured from others according to published data, specifications or performance information not designed by or for Seller.

Seller further agrees to replace or at Seller's option to provide a refund of the sales price of any goods that do not conform to applicable specifications or which differ from that agreed to be supplied which non-conformity is discovered and forthwith reported to Seller within thirty (30) days after shipment to the Buyer. Seller's obligation to replace or refund the purchase price for non-conforming goods shall arise once Buyer returns such goods FOB point of original shipment by Seller at the risk and cost of Buyer. Goods replaced by Seller shall become the property of Seller.

There is no guarantee or warranty as to anything made or sold by Seller, or any services performed, except as to title and freedom from encumbrances and, except as herein expressly stated and particularly, and without limiting the foregoing, **there is no guarantee or warranty, express or implied, of merchantability or of fitness for any particular purpose or against claim of infringement or the like.**

Seller makes no warranty (and assumes no liability) as to function of equipment or operation of systems built to Buyer's design or of the ability of any goods to interface, operate or function with any portions of Buyer's system not provided by Seller.

Seller's liability on any claim, whether in contract, tort (including negligence), or otherwise, for any loss or damage arising out of, connected with, or resulting from the manufacture, sale, delivery, resale, repair, replacement or use of any products or services shall in no case exceed the price paid for the product or services or any part thereof which give rise to the claim. In no event shall Seller be liable for consequential, special, incidental or other damages, nor shall Seller be liable in respect of personal injury or damage to property not the subject matter hereof unless attributable to gross misconduct of Seller, which shall mean an act or omission by Seller demonstrating reckless disregard of the foreseeable consequences thereof.

Seller is not responsible for incorrect choice of models or where products are used in excess of their rated and recommended capacities and design functions or under abnormal conditions. Seller assumes no liability for loss of time, damage or injuries to property or persons resulting from the use of Seller's products. Buyer shall hold Seller harmless from all liability, claims, suits and expenses in connection with loss or damage resulting from operation of products or utilization of services, respectively, of Seller and shall defend any suit or action which might arise there from in Buyer's name - provided that Seller shall have the right to elect to defend any such suit or action for the account of Buyer. The foregoing shall be the exclusive remedies of the Buyer and all persons and entitles claiming through the Buyer.

Conductors -4

Hanger Clamps - 4

Joining Conductor Sections - 5

Expansion Gaps - 5

Isolation Joints - 6

Bending and Cutting - 6

Powerfeed - 6

End Cover - 6

Saf-T-Bar Collectors - 7

Conductors

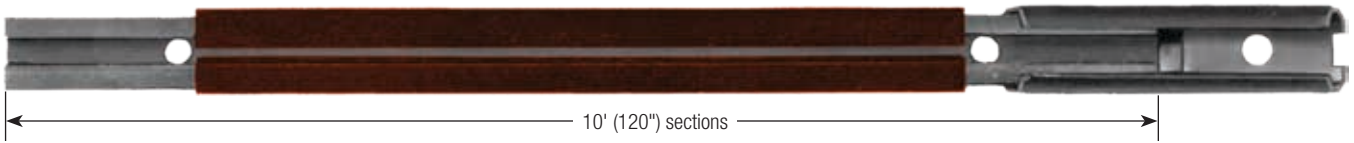

Hanger Clamps

Hanger Clamps are stamped cold rolled steel, nylon coated. May be furnished in multiples on 1" centers. Can be mounted using cross bolt or back bolt. Bolts are 1/4" and require a 5/16" mounting hole. Hangers are required every 5' of conductor. Joints should not be located more than 3" from hangers to avoid flexing.

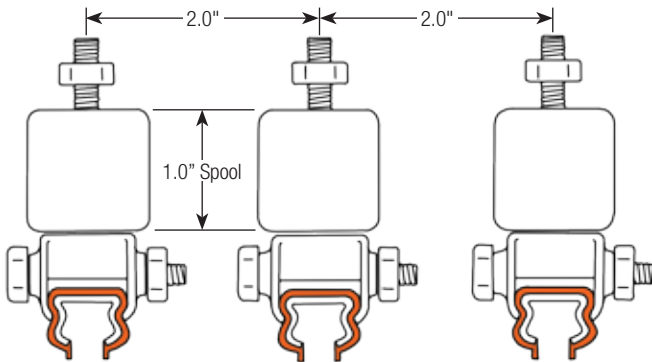
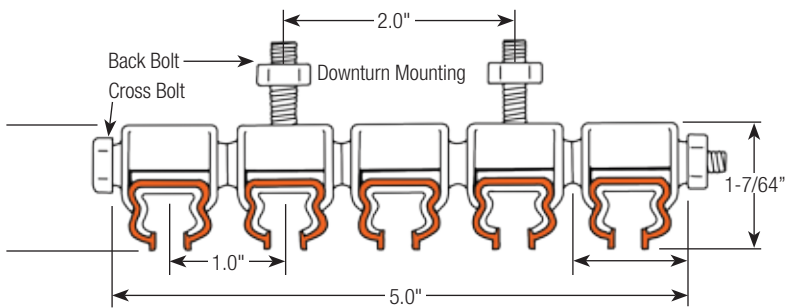

Spool Hanger Mounting
TH101K

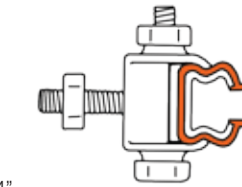
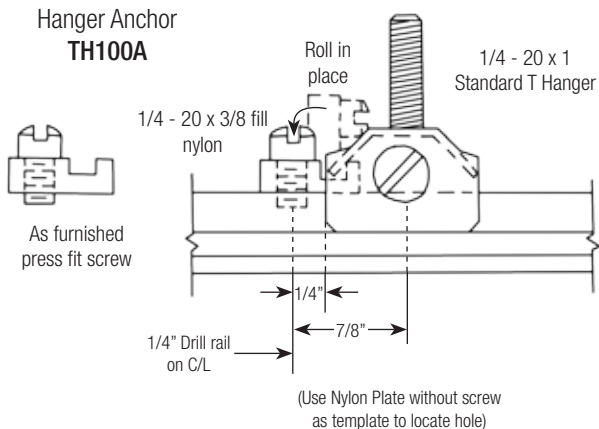

TH101

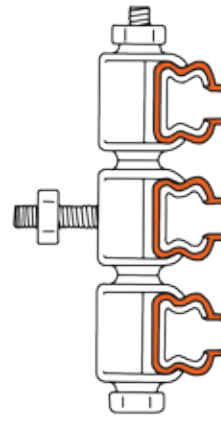

TH301

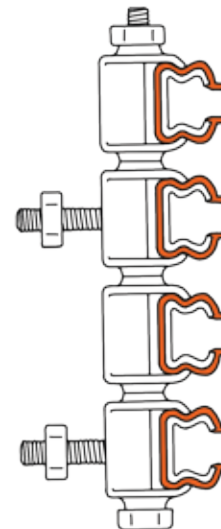

TH402

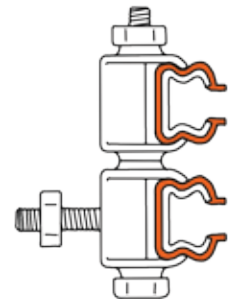

TH201

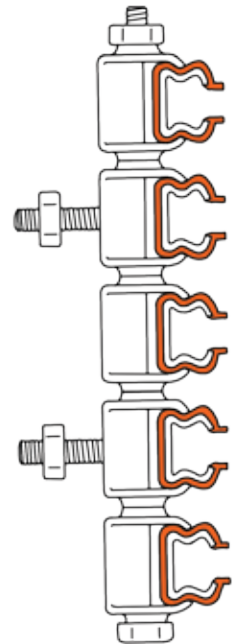

TH502

WARNING: Power Service Disconnect must be locked in the OFF position before attempting any conductor service.

Joining Conductor Sections

The joint splice assembly connects and aligns standard 10' conductor lengths. The joint clip is furnished in place on one end of the conductor. End of adjacent conductor slides into joint clip and is pulled up tight with joint tool.

A 4" joint cover slides over the exposed joint area to complete the insulation. The joint cover locks into place by means of indents and is formed of the same material as the insulating conductor cover.



Joint Kit TJ65 Steel - Standard

Joining Sections is Quick as ABC...

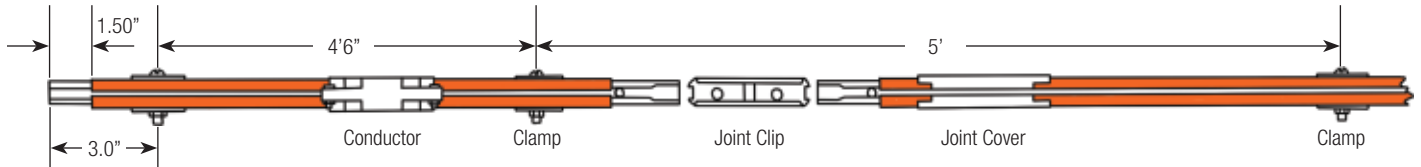

A Slide hanger clamps on bar. Secure clamps in mounting holes on brackets. Be sure bar slides smoothly inside each clamp (until joining operation is completed). Maintain 3" spacing at ends of bars.

B Slide joint cover over bar.

C Insert Joint Tool (TY65 recommended) into holes at ends of Bars. Draw Bars together until they butt. Slide cover over joint. Tighten clamps on bar.

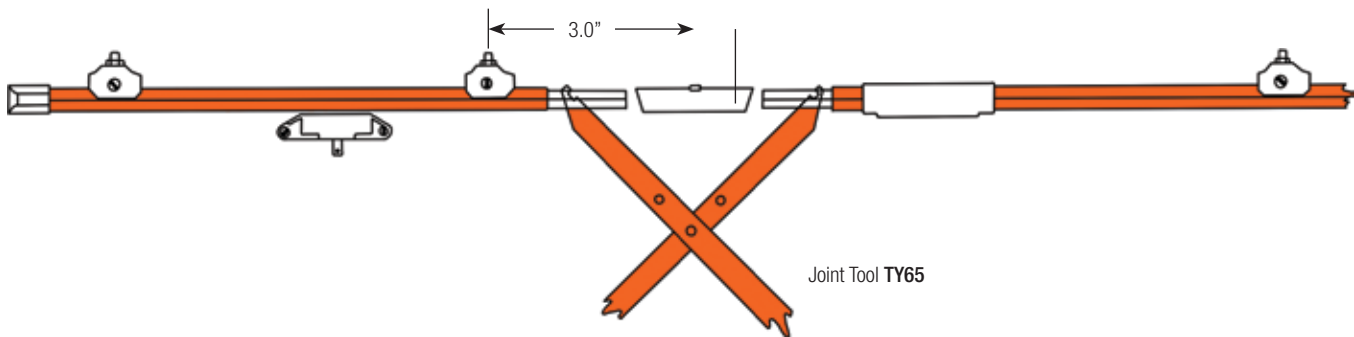

Note: Single conductor is shown here for purpose of simple illustration. Multiple conductor installations follow same step-by-step procedure concurrently. Joints may be secured from either front or back of bars.

Expansion Gaps



Expansion Kits
TA65XF Per Phase

Expansion gaps may be required every 150 feet for steel conductors, and every 100 feet for copper conductors, this length expanding 1" in 100°F temperature change. Set up gap with jumper as shown, e.g.: 0°F 1" gap, 50°F .50" gap, 100°F 0" gap. Two extra power feeds and a jumper bridge the gap electrically. Hanger clamps held in the grooved **Gap Guide Bracket** align the two conductors. Extended joint cover and insulating cover complete the installation. The support bolt on the guide frame must go to a conductor mounting bracket. **(For low amperage applications, if there are no runway expansion gaps may be omitted. If in doubt, consult the factory.)**

Isolation Points

A rigid plastic sleeve, providing 0.50" over surface gap electrically, for electrical segmentation of conductor bars. A self supporting sleeve. **TA65IS**

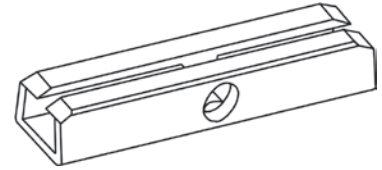

Bending and Cutting

Saf-T-Bar may be bent against the back, or the open face, of the conductor (the easy way). Minimum radius 18.0". Bending against the side of the conductor (the hard way) **requires factory bending to order**. Minimum radius 24.0". Conductor may be cut with a hacksaw and filed smooth. Drill a 0.25" hole, 1.50" from end to receive the joint tool. 12.0" radii may be formed if 30-amp collectors are used. **Factory bends are recommended.**

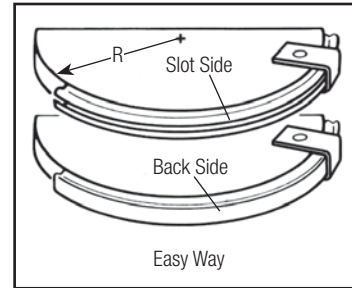

Power Feed

A terminal lug with insulating cover, **TF100** is provided as a feed which clamps onto 3/4" length of bare conductor and which will accept wires up to #6 flex. Rated at 100 amperes it is used in pairs for higher ampere requirements. The conductor may also be fed by securing a standard terminal lug to the 1/4" hole in the end of the conductor and taping over it for insulation.

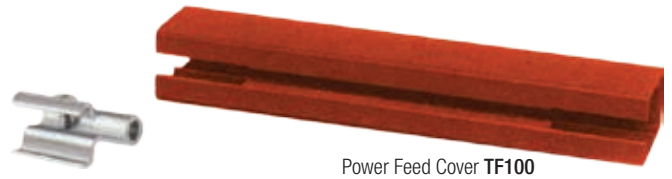

Power Feed Cover **TF100**

End Cover

The end cover, **TN100C**, required to complete the insulation of the conductor, is a sleeve extending 1/2" over the end of the bar. As an alternative, the conductor may be cut back so that the regular insulating cover extends 1/2" beyond the end of the conductor. This end cover may also be used as a transfer end cap having a 1/8" tolerance with a 1" gap setting on interlocks.

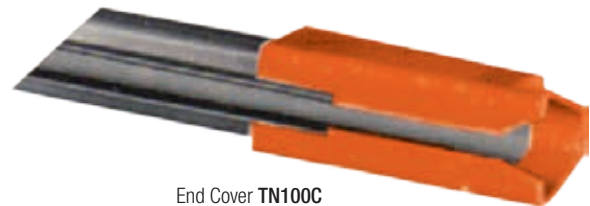

End Cover **TN100C**

Saf-T-Bar Collectors

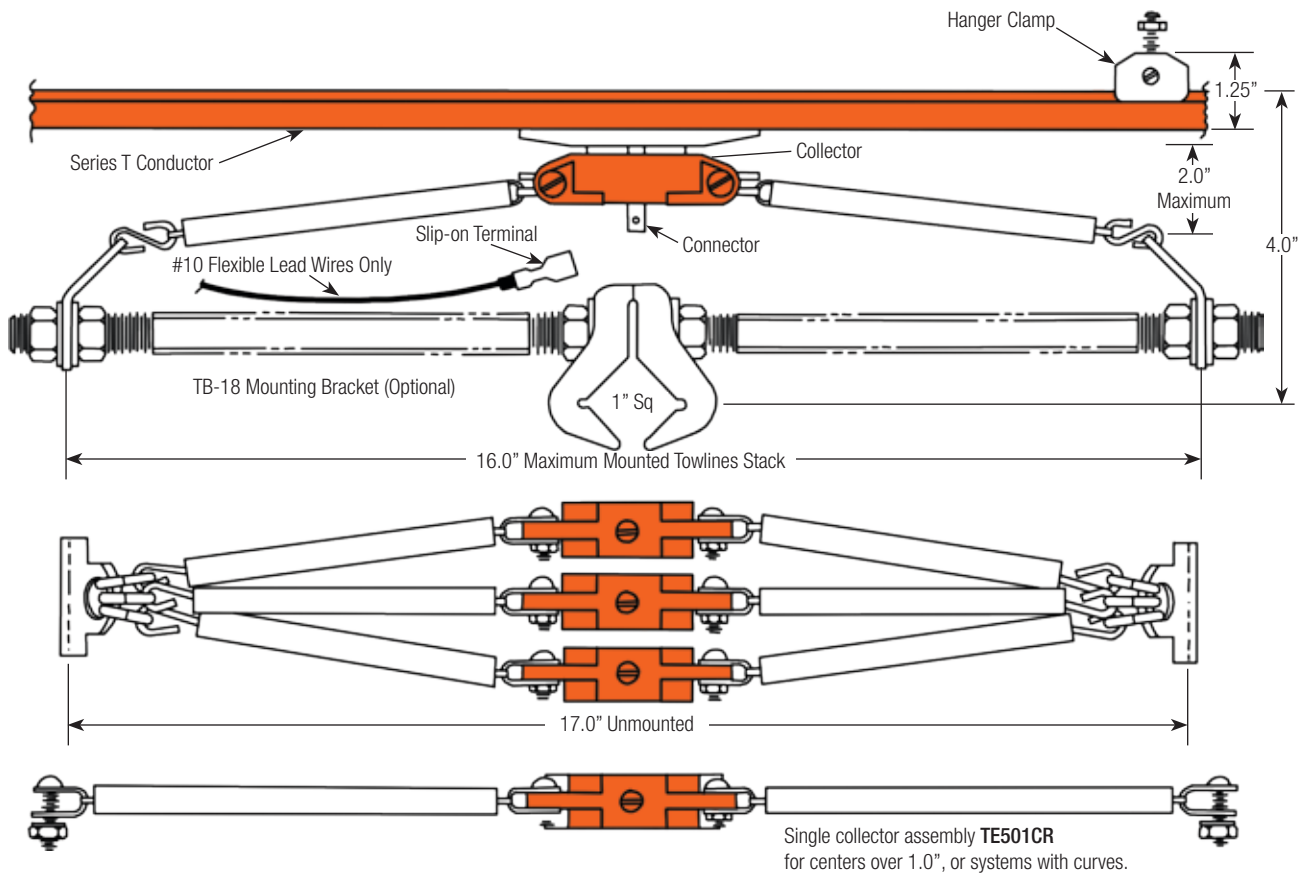

Standard Collection Shoe for straight runs.
Suitable for transfers at switches and interlocks



Short Shoe Collector for small radius-12.0"

Series T Collectors in the 50 amps configuration are available as **TE501CR/2CR/3CR** using copper graphite contact material. This is a self lubricating contact for quiet long life operation.

The **TE30-1/2/3** collector uses Chromium Copper contact material and the short length of the shoe allows use on curves down to 12" radius. The collectors are supplied as single phase units complete with tow lines and a 3-phase unit i.e. **TE503CR** would be supplied as 3 pcs. **TE501CR**.

www.conductix.us

Conductix-Wampfler

10102 F Street
Omaha, NE 68127
USA

Customer Support
Phone: 800 521 4888
Fax: 800 780 8329

Phone: 402 339 9300
Fax: 402 339 9627

info.us@conductix.com
www.conductix.com

