

Festoon Manual

Heavy Duty Square Bar

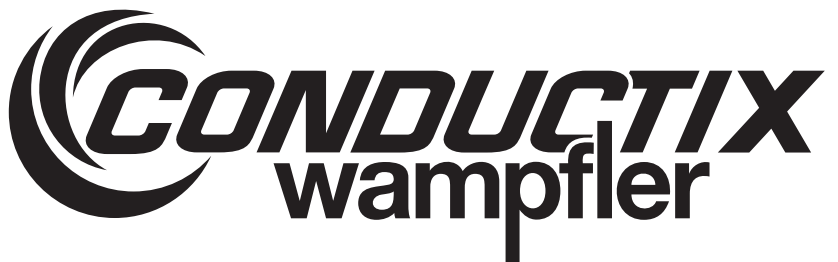
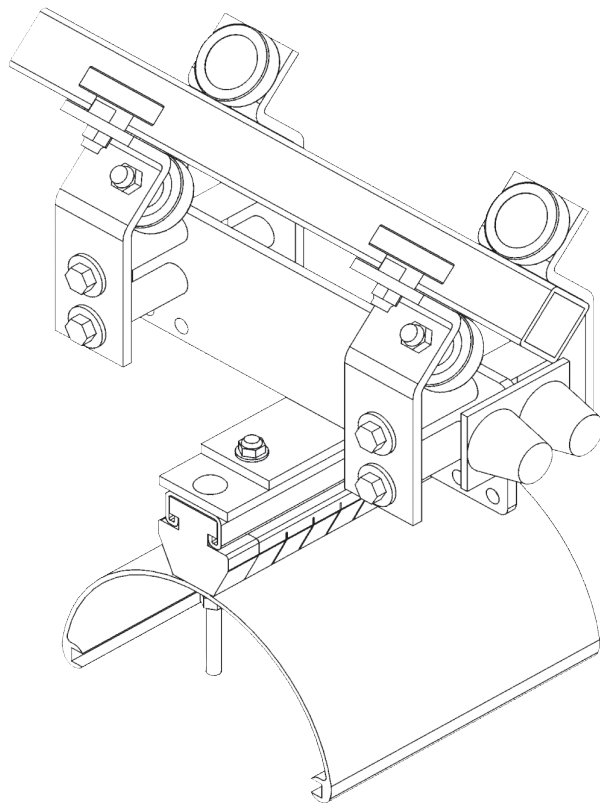

Conductix Incorporated

The technical data and images which appear in this manual are for informational purposes only. **NO WARRANTIES, EXPRESS OR IMPLIED, INCLUDING WARRANTIES OF MERCHANTABILITY OR FITNESS FOR A PARTICULAR PURPOSE, ARE CREATED BY THE DESCRIPTIONS AND DEPICTIONS OF THE PRODUCTS SHOWN IN THIS MANUAL.** Conductix makes no warranty (and assumes no liability) as to function of equipment or operation of systems built according to customer design or of the ability of any of its products to interface, operate or function with any portions of customer systems not provided by Conductix.

Seller agrees to repair or exchange the goods sold hereunder necessitated by reason of defective workmanship and material discovered and reported to Seller within one year after shipment of such goods to Buyer.

Except where the nature of the defect is such that it is appropriate, in Seller's judgment, to effect repairs on site, Seller's obligation hereunder to remedy defects shall be limited to repairing or replacing (at Seller's option) FOB point of original shipment by Seller, any part returned to Seller at the risk and cost of Buyer. Defective parts replaced by Seller shall become the property of Seller.

Seller shall only be obligated to make such repair or replacement if the goods have been used by Buyer only in service recommended by Seller and altered only as authorized by Seller. Seller is not responsible for defects which arise from improper installation, neglect, or improper use or from normal wear and tear.

Additionally, Seller's obligation shall be limited by the manufacturer's warranty (and is not further warranted by Seller) for all parts procured from others according to published data, specifications or performance information not designed by or for Seller.

Seller further agrees to replace or at Seller's option to provide a refund of the sales price of any goods that do not conform to applicable specifications or which differ from that agreed to be supplied which non-conformity is discovered and forthwith reported to Seller within thirty (30) days after shipment to the Buyer. Seller's obligation to replace or refund the purchase price for non-conforming goods shall arise once Buyer returns such goods FOB point of original shipment by Seller at the risk and cost of Buyer. Goods replaced by Seller shall become the property of Seller.

There is no guarantee or warranty as to anything made or sold by Seller, or any services performed, except as to title and freedom from encumbrances and, except as herein expressly stated and particularly, and without limiting the foregoing, **there is no guarantee or warranty, express or implied, of merchantability or of fitness for any particular purpose or against claim of infringement or the like.**

Seller makes no warranty (and assumes no liability) as to function of equipment or operation of systems built to Buyer's design or of the ability of any goods to interface, operate or function with any portions of Buyer's system not provided by Seller.

Seller's liability on any claim, whether in contract, tort (including negligence), or otherwise, for any loss or damage arising out of, connected with, or resulting from the manufacture, sale, delivery, resale, repair, replacement or use of any products or services shall in no case exceed the price paid for the product or services or any part thereof which give rise to the claim. In no event shall Seller be liable for consequential, special, incidental or other damages, nor shall Seller be liable in respect of personal injury or damage to property not the subject matter hereof unless attributable to gross misconduct of Seller, which shall mean an act or omission by Seller demonstrating reckless disregard of the foreseeable consequences thereof.

Seller is not responsible for incorrect choice of models or where products are used in excess of their rated and recommended capacities and design functions or under abnormal conditions. Seller assumes no liability for loss of time, damage or injuries to property or persons resulting from the use of Seller's products. Buyer shall hold Seller harmless from all liability, claims, suits and expenses in connection with loss or damage resulting from operation of products or utilization of services, respectively, of Seller and shall defend any suit or action which might arise there from in Buyer's name - provided that Seller shall have the right to elect to defend any such suit or action for the account of Buyer. The foregoing shall be the exclusive remedies of the Buyer and all persons and entitles claiming through the Buyer.

1.0 Safety

- 1.1 Electrical Warnings
- 1.2 Operational Warnings
- 1.3 Maintenance Warnings

2.0 Installation

3.0 Operation

- 3.1 Pre-Operation Inspection
- 3.2 Operation Instructions

4.0 Maintenance

1.0 Safety

1.1 Electrical Warnings

- 1.1.1 Properly ground all electrical connections in accordance with the National Electric Code and local codes and ordinances.
- 1.1.2 Disconnect the electrical power from the system before any service is performed.
- 1.1.3 Do not use cable for loads greater than the voltage and current rating. The ampacity rating of the cable should be in accordance with the National Electric Code.

1.2 Operational Warnings

- 1.2.1 Exercise care when handling the festoon system during normal operations.
- 1.2.2 **IMPORTANT:** Do not use cable different from that for which the system is intended. **Changes in diameter, weight per foot, length of cable or flexibility will affect the operation of the system.**
- 1.2.3 Mounting hardware and fasteners should be installed to maintain tightness under vibration and check periodically to insure tightness.

1.3 Maintenance Warnings

- 1.3.1 **WARNING: Modification of this equipment may cause excessive wear and will void the warranty.** Contact Insul-8 Corporation regarding changes or modifications of equipment which could affect reliability or safety.

2.0 Installation

2.1 Square Bar

- 2.1.1 Cut straight length square bar(s) to proper length(s). Drill hanger support structure locations.
Note: Review hanger position and splice locations before drilling.
- 2.1.2 Attach hangers to support structure (See General Arrangement Drawing for Correct Hanger Spacing)
- 2.1.3 Mark hanger and end clamp position on square bar. Position drill fixture and drill as required.
Note: Heavy Duty Square Bar uses 5/16" drill bit.
- 2.1.4 Mount square bar onto hangers.
- 2.1.5 Adjacent square bar lengths:
 - a) mark and drill hanger locations
 - b) attach splice couplers
 - c) mount square bar hangers and splice to existing bar
- 2.1.6 Determine loop depth of cable. Mark cable where it will be positioned on the saddle, install cable onto trolley saddles, placing the cable mark between the clamp bolts. Allow extra length of cable for hook-up area **BEFORE** tow trolley and **AFTER** end clamp. Attach tow cables between each trolley.
- 2.1.7 Install carriers onto square bar.
- 2.1.8 Mount end clamp onto square bar.
- 2.1.9 Install tow device. Towing device shall move the trolley parallel to the track and not strain against the trolley travel direction.
- 2.1.10 Verify electrical power is off. Cycle the system manually to ensure proper travel.
- 2.1.11 Terminate all electrical connections and test mobile electrical system. Cycle the system under supervision.

2.0 Installation

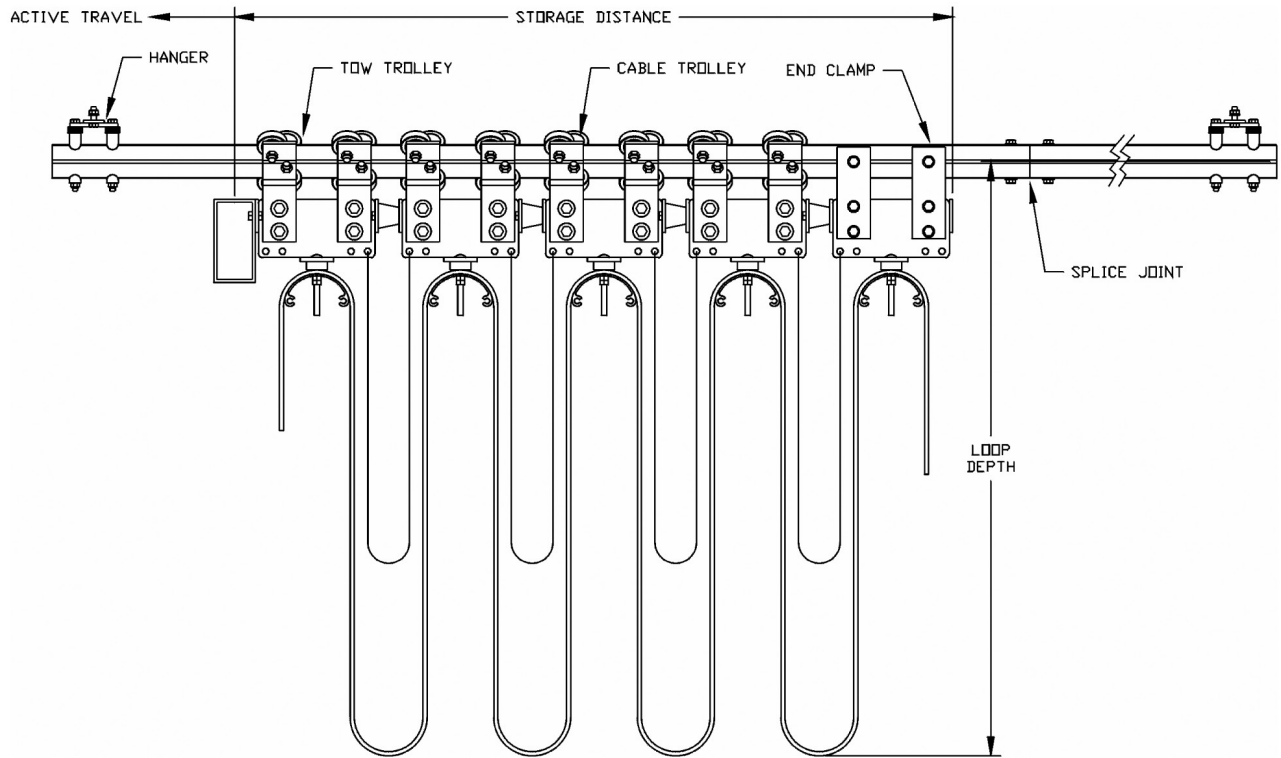

3.0 Operation

3.1 Pre-Operation Inspection

- 3.1.1 Check for proper mounting of end clamp.
- 3.1.2 Check for obstructions on square bar joints.

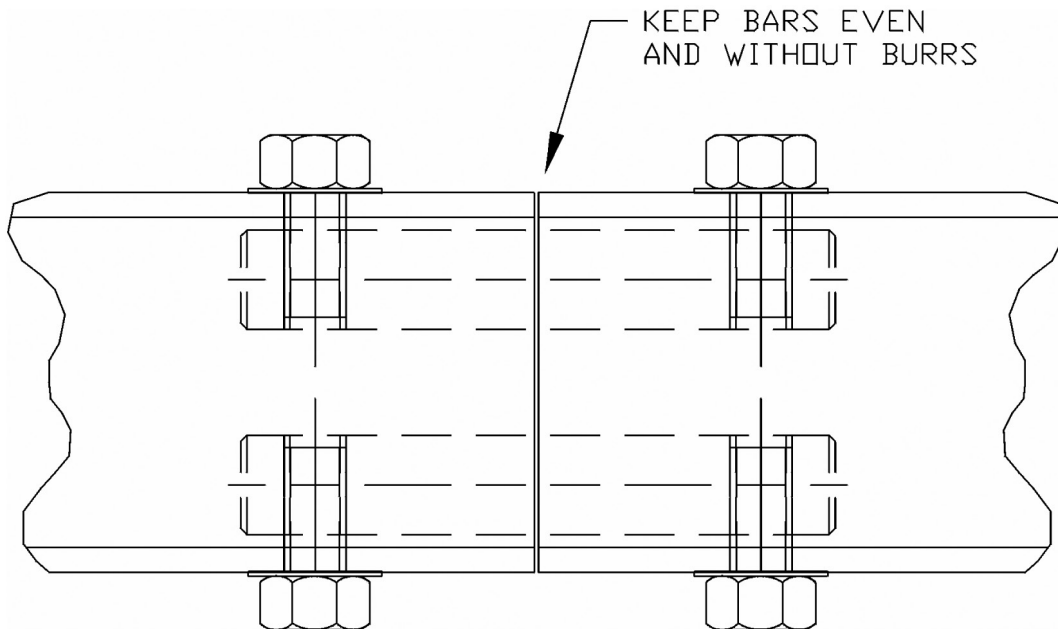

3.0 Operation

- 3.1.3 Check cable clearances and that cables are hanging properly and are not tangled.
- 3.1.4 Check that tow arm is not disengaged from tow trolley during test operation and remains within the confines of the tow box. (Tow arm must move freely in the tow box)
- 3.1.5 If new system is a replacement system, double check the storage distance requirement to ensure there is enough room for the festoon in the stored position.

3.2 Operation Instructions

- 3.2.1 Do not exceed the voltage or ampere rating of the cable. Overheating, fire, damage to equipment or personal injury could result.
- 3.2.2 Operate the festoon system within the electrical and mechanical limits for which it was intended.

4.0 Maintenance

4.1 Maintenance Instructions

4.1.1 In general, since all trolley rollers are lubricated and sealed, no re-greasing is required. However, customer should conduct periodic inspections of the square bar system. Determine the inspection intervals based on severity of duty cycle (level of usage) and environment. A reference schedule of inspections is listed below:

Service	Inspection Rates
Severe	3 months
Normal	6 months
Light	12 months

4.1.2 Insul-8 recommends the following checks during inspections:

- a) Check all rollers for wear.
- b) Check tightness of all hardware
- c) Check cable clamp of all trolleys, making sure cable remains secure
- d) Inspect cable insulation for any cuts or cracks
- e) Check bumper condition
- f) Check condition of all accessories, tow ropes, shock cords and cable organizers
- g) Inspect square bar for wear, clean running surface of any debris or build up.

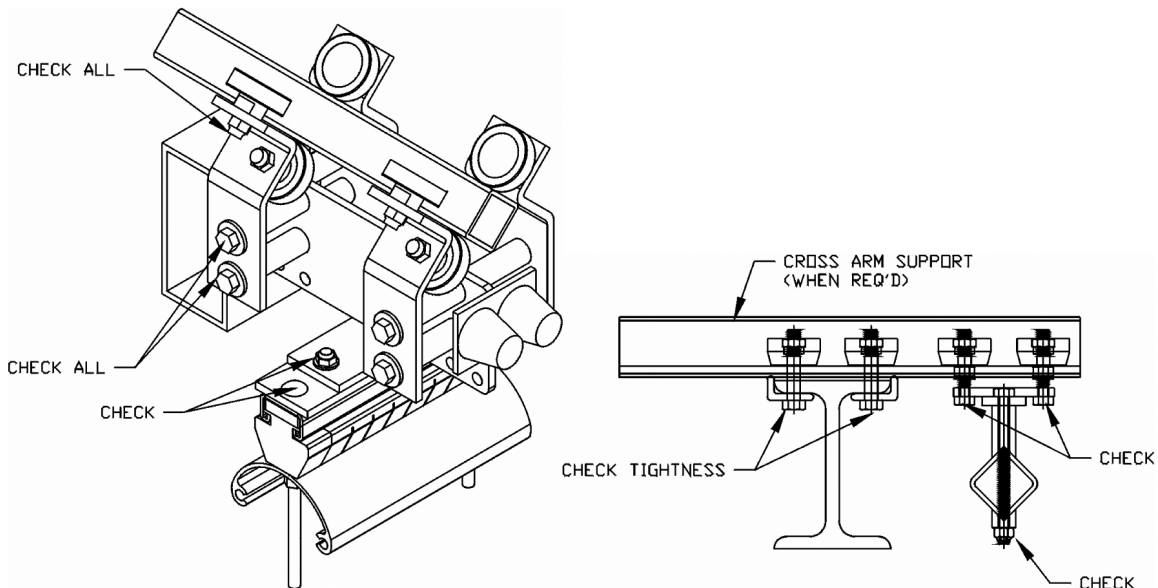

Notes

www.conductix.us

USA / LATIN AMERICA

10102 F Street
Omaha, NE 68127

Customer Support

Phone +1-800-521-4888

Phone +1-402-339-9300

Fax +1-402-339-9627

info.us@conductix.com

latinamerica@conductix.com

CANADA

1435 Norjohn Court
Unit 5
Burlington, ON L7L 0E6

Customer Support

Phone +1-800-667-2487

Phone +1-450-565-9900

Fax +1-450-851-8591

info.ca@conductix.com

MÉXICO

Calle Treviño 983-C
Zona Centro
Apodaca, NL México 66600

Customer Support

Phone (+52 81) 1090 9519

(+52 81) 1090 9025

(+52 81) 1090 9013

Fax (+52 81) 1090 9014

info.mx@conductix.com

BRAZIL

Rua Luiz Pionti, 110
Vila Progresso
Itu, São Paulo, Brasil
CEP: 13313-534

Customer Support

Phone (+55 11) 4813 7330

Fax (+55 11) 4813 7357

info.br@conductix.com

Contact us for our Global Sales Offices

