

Pendant Manual Series 20

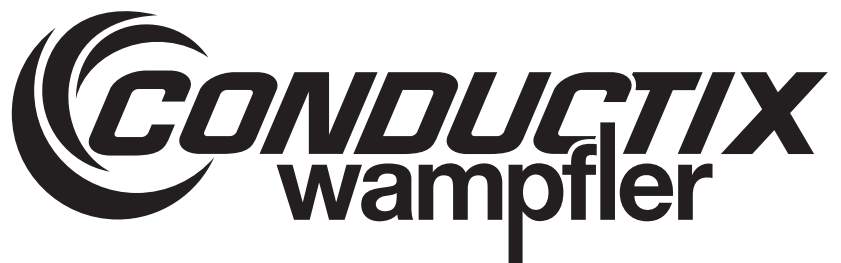

Conductix Incorporated

The technical data and images which appear in this manual are for informational purposes only. **NO WARRANTIES, EXPRESS OR IMPLIED, INCLUDING WARRANTIES OF MERCHANTABILITY OR FITNESS FOR A PARTICULAR PURPOSE, ARE CREATED BY THE DESCRIPTIONS AND DEPICTIONS OF THE PRODUCTS SHOWN IN THIS MANUAL.** Conductix makes no warranty (and assumes no liability) as to function of equipment or operation of systems built according to customer design or of the ability of any of its products to interface, operate or function with any portions of customer systems not provided by Conductix.

Seller agrees to repair or exchange the goods sold hereunder necessitated by reason of defective workmanship and material discovered and reported to Seller within one year after shipment of such goods to Buyer.

Except where the nature of the defect is such that it is appropriate, in Seller's judgment, to effect repairs on site, Seller's obligation hereunder to remedy defects shall be limited to repairing or replacing (at Seller's option) FOB point of original shipment by Seller, any part returned to Seller at the risk and cost of Buyer. Defective parts replaced by Seller shall become the property of Seller.

Seller shall only be obligated to make such repair or replacement if the goods have been used by Buyer only in service recommended by Seller and altered only as authorized by Seller. Seller is not responsible for defects which arise from improper installation, neglect, or improper use or from normal wear and tear.

Additionally, Seller's obligation shall be limited by the manufacturer's warranty (and is not further warranted by Seller) for all parts procured from others according to published data, specifications or performance information not designed by or for Seller.

Seller further agrees to replace or at Seller's option to provide a refund of the sales price of any goods that do not conform to applicable specifications or which differ from that agreed to be supplied which non-conformity is discovered and forthwith reported to Seller within thirty (30) days after shipment to the Buyer. Seller's obligation to replace or refund the purchase price for non-conforming goods shall arise once Buyer returns such goods FOB point of original shipment by Seller at the risk and cost of Buyer. Goods replaced by Seller shall become the property of Seller.

There is no guarantee or warranty as to anything made or sold by Seller, or any services performed, except as to title and freedom from encumbrances and, except as herein expressly stated and particularly, and without limiting the foregoing, **there is no guarantee or warranty, express or implied, of merchantability or of fitness for any particular purpose or against claim of infringement or the like.**

Seller makes no warranty (and assumes no liability) as to function of equipment or operation of systems built to Buyer's design or of the ability of any goods to interface, operate or function with any portions of Buyer's system not provided by Seller.

Seller's liability on any claim, whether in contract, tort (including negligence), or otherwise, for any loss or damage arising out of, connected with, or resulting from the manufacture, sale, delivery, resale, repair, replacement or use of any products or services shall in no case exceed the price paid for the product or services or any part thereof which give rise to the claim. In no event shall Seller be liable for consequential, special, incidental or other damages, nor shall Seller be liable in respect of personal injury or damage to property not the subject matter hereof unless attributable to gross misconduct of Seller, which shall mean an act or omission by Seller demonstrating reckless disregard of the foreseeable consequences thereof.

Seller is not responsible for incorrect choice of models or where products are used in excess of their rated and recommended capacities and design functions or under abnormal conditions. Seller assumes no liability for loss of time, damage or injuries to property or persons resulting from the use of Seller's products. Buyer shall hold Seller harmless from all liability, claims, suits and expenses in connection with loss or damage resulting from operation of products or utilization of services, respectively, of Seller and shall defend any suit or action which might arise there from in Buyer's name - provided that Seller shall have the right to elect to defend any such suit or action for the account of Buyer. The foregoing shall be the exclusive remedies of the Buyer and all persons and entitles claiming through the Buyer.

INDEX

1.0 Features and Specifications

- 1.1 Features
- 1.2 Mechanical Specifications
- 1.3 Electrical Specifications

2.0 Installation

- 2.1 Legend Insert Replacement

1.0 Features and Specifications

NEMA 4X and 12, General Purpose Direction Operation Hoist Pendant Station

1.1 Features

- 1.0.1 Designed for use with single phase motors up to 1HP, 120VAC (2HP, 230VAC).
- 1.0.2 The enclosure is a high-visibility orange color and is constructed of high-impact, high-strength flame retardant plastic, for operator safety.
- 1.0.3 Pendant is ergonomically designed for single hand operation.
- 1.0.4 The unit is dust-tight, drip-tight, and completely insulated to prevent electrical shock.
- 1.0.5 An external strain-relief tie point and an internal cable-clamp are provided for added support.
- 1.0.6 A flexible cable entry bushing provides superior protection against the entry of foreign matter, and is easily selected to fit cable diameter.
- 1.0.7 Various standard pushbutton legends are available for marking each pushbutton.

1.2 Mechanical Specifications

- 1.1.1 **RECOMMENDED CABLE:** Type SO or equivalent, copper conductors, 75°C, size 10 AWG, 6 conductor maximum.
- 1.1.2 **CABLE DIAMETERS FOR BUSHINGS SUPPLIED:** Min. 8mm through 14mm Max.
- 1.1.3 **EXTERNAL STRAIN RELIEF:** An external strain-relief tie point on the bushing collar has been supplied for the connection of an external-relief wire attached to the upper junction box of the cable.
- 1.1.4 **INTERNAL STRAIN RELIEF:** An internal strain-relief screw has been supplied for optional use of an internal strain relief wire used in some cables, torque screw - 14 in. - lbs.
- 1.1.5 **TORQUE VALUES:**
 - Enclosure screws: 15 in.-lbs.
 - Internal cable-clamp: 10 in.-lbs.
 - Electrical terminal screws: 10 in.-lbs.
 - External cable-bushing clamp: 10 in.-lbs.
 - Switch mounting screws: 20 in.-lbs.
 - Cable-bushing clamp: 25 in.-lbs.

1.3 Electrical Specifications

- 1.2.1 120VAC, 1HP 230VAC, 2HP
- 1.2.2 120VAC, 25A resistive general purpose (intended for intermittent duty using a 10 AWG conductors that is not in excess of 6 feet).
- 1.2.3 Recommended short circuit protection...25A time delay fuse (for 230VAC/2HP rating) AC3 rating: 250VAC, 16A for 250,000 operations.

Warning! Turn off all power supply sources and lockout while working on pendant.

2.0 Installation

- 2.0.1 Loosen four (4) rear cover screws and remove back cover from pendant.
- 2.0.2 Remove two (2) screws on top of pendant and remove top bushing collar. Slide the external cable-bushing housing up the cable before putting the cable through the bushing.
- 2.0.3 Slide the bushing over the cable with clamp making sure the bushing top entry fits snugly over the cable. If the bushing is loose, an adequate seal will not be achieved and moisture may leak inside the pendant. Contact Conductix-Wampfler or your dealer should the cable fit too loosely. Trim bushing to correct cable size if required. Use a lubricant if necessary to feed the cable through the bushing.
- 2.0.4 Slide the cable into the top of the pendant and underneath the internal cable-clamp. Slide the bushing collar down the cable and over the bushing, and screw down into place making sure that the bottom of the bushing is seated properly in the top of the pendant. Tighten the internal cable clamp to recommended torque values.
- 2.0.5 Terminate wires to be connected to the unit with UL listing ring terminals. Connect wiring connections to the push-button terminals using the typical wiring schematic in Fig.1. and also using the recommended torque values above. Keep wire lengths as short as possible.
- 2.0.6 Once wires have been terminated inspect for correct visual operation of contacts. Depress each pushbutton and verify that each button returns freely to open position. Also check operation of mechanical interlock. Tighten switch-mounting screws if switch block appears loose. Observe torque values above when installing or replacing any components.
- 2.0.7 Re-install the rear cover observing torque values above.
- 2.0.8 Check operation of pendant before returning to service. Do not use any piece of equipment that demonstrates irregular operation.

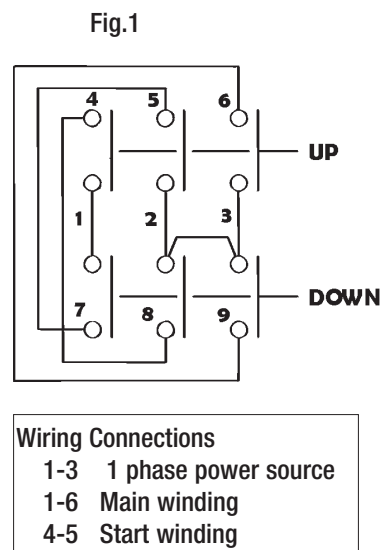

2.1 Legend Insert Replacement

- 2.2.1 Remove existing legend insert by using a small screwdriver to pry off the plastic button cover.
- 2.2.2 Place the new insert in the recessed area, and replace the plastic cover by lining up the guide notches and depressing it into place.
- 2.2.3 All Conductix-Wampfler Series 20 pushbutton switches come equipped with an ANSI warning label. Should this label become illegible contact Conductix-Wampfler for a replacement.

Notes

Notes

www.conductix.us

USA / LATIN AMERICA

10102 F Street
Omaha, NE 68127

Customer Support
Phone +1-800-521-4888

Phone +1-402-339-9300
Fax +1-402-339-9627

info.us@conductix.com
latinamerica@conductix.com

CANADA

1435 Norjohn Court
Unit 5
Burlington, ON L7L 0E6

Customer Support
Phone +1-800-667-2487

info.ca@conductix.com

MÉXICO

Calle Treviño 983-C
Zona Centro
Apodaca, NL México 66600

Customer Support
Phone (+52 81) 1090 9519
(+52 81) 1090 9025
(+52 81) 1090 9013

Fax (+52 81) 1090 9014

info.mx@conductix.com

BRAZIL

Rua Dois, 493
Itu, São Paulo, Brasil
CEP: 13312-820

Customer Support
Phone (+55 11) 4813 7330

Fax (+55 11) 4813 7330

info.br@conductix.com

Contact us for our Global Sales Offices

