

# QuickBridge™

Modern Overhead Crane Bridge Electrification



**CONDUCTIX**  
wampfler

# Features and Benefits

**QuickBridge™** is a new concept in bridge electrification to give your overhead cranes a clean, contemporary look. QuickBridge eliminates traditional cable festoon and does it better than cable chain systems. QuickBridge features conductor bar for bridge power and wireless radio remote controls for hoist control. This combination supplies crane bridge electrification that is efficient, safe, rugged, and reliable. The QuickBridge design increases available bridge travel, maximizes below-the-hook working space, and reduces downtime to ensure peak equipment availability.

How does QuickBridge compare to traditional festoon and cable chain solutions?

- ✔ Increases bridge travel by eliminating the festoon cable storage area or cable chain loop.
- ✔ Increases overhead clearance by eliminating vertical festoon cable loops.
- ✔ Reduces installation time by eliminating the need to strip flat cables and load them into carriers.
- ✔ Reduces time and material costs associated with replacing cable chain or trolleys. Conductor bar shoes are easy to replace.
- ✔ Eliminates the need to monitor cable wear and replace cables.
- ✔ Replaces pendant control with radio control which allows the operator to run the crane away from the load.
- ✔ Provides freedom of movement for the operator.

Try the QuickBridge method of crane bridge electrification and experience increased reliability, reduced installation time, and maximized workspace.

## Standard Conductor Bar Configurations (Alternate Conductor Bar styles are available by request)

### Safe-Lec 2



#### Single Pole Conductor System

- 100 amp maximum capacity, actual capacity is dependent on system length (higher capacities available).
- Our most popular bar features a “V-Contact” to ensure positive shoe tracking and continuous conductivity.
- Bolted bar splices provide positive connections that cannot pull apart.
- IP2 rated “finger-safe” conductor bar insulation provides electrically safe operation.
- Open rail for quick shoe inspection.
- Convenient 14.7 foot (4.5 meter) sections.

### 842 Series BoxLine





#### Compact Enclosed Conductor System

- Up to 60 amp capacity depending on system length.
- Compact design reduces the area required for installation; perfect for space constrained applications.
- Enclosed profile with captured collector for an ultra-clean look.
- Quick installation - all four poles are housed within a single extrusion and suspended with a snap-in hanger.
- Easy to handle 13.5 foot (4 meter) sections.
- IP2 rated “finger-safe” conductor bar insulation provides electrically safe operation.

# Selection Guide

## Configuring QuickBridge in Four Easy Steps

Configuring your QuickBridge system is easy. Follow the four step process below to guide you through the selection process and assemble the perfect modern electrification solution.

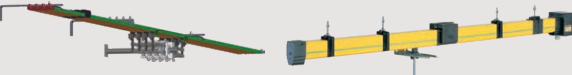
Step 1	<b>Identify Control Type</b> (see pages 4-7) <ul style="list-style-type: none"> <li>• Single speed or two-speed</li> <li>• One hoist or two hoists</li> </ul>	
Step 2	<b>Identify Rail Type</b> (see pages 8-9) <ul style="list-style-type: none"> <li>• Single pole 100 amp Safe-Lec 2</li> <li>• Or enclosed 60 amp 842 Series</li> </ul>	
Step 3	<b>Identify Mounting Type</b> (see page 10)	 <p style="text-align: center;">Web Bracket   Flange Bracket   842 Bracket   Lateral Mount</p>
Step 4	<b>Identify System Length</b> (see page 11)	

Each QuickBridge System is preconfigured to include standard components:

- NEMA-4 rated (IP56) Radio transmitters and receivers for control.
- Conductor bar for three phase power, and end power feeds.
- Tandem Collectors for each hoist.
- All necessary installation hardware – hangers, anchors, joint covers, and end caps.

**System Numbering Scheme** (Using codes described on the following pages)

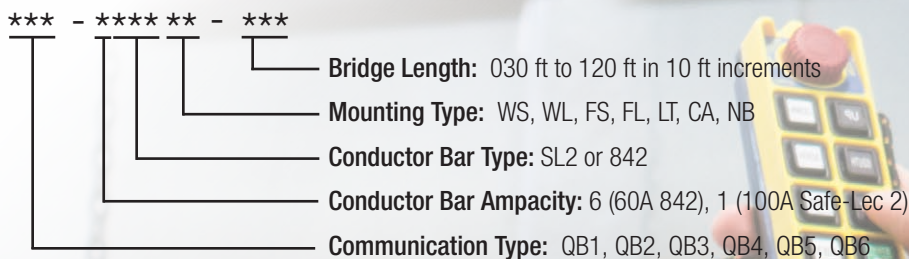

**Example System Number**

**QB3 - 1SL2WL - 060** = Saga K3 Single Speed Radios to control bridge travel and two hoists + 100 A Safe-Lec 2 bar with long web brackets, for a 60 foot long bridge

# STEP 1 Control Types - Single Speed Radios

## Two Hoists

Control Type	Radio Model	Speed	# of Hoists	# of Receivers Per Kit	# of Transmitters Per Kit	Max Operating Range (ft) *	Channels	Buttons
QB3	K3	Single	Two	3	2	1000	70	12

\* Depending on the environment

### QB3



### K3

Digital Radio

Start button

Split commons

Integrated horn/alarm

Jammed button detection

Toggle switch for A/B Both control

Visual indication of A/B Both control

Advanced two hoist button mapping available\*

Single post mounting

Numbered wiring

# STEP 1 Control Types - Dual Speed Radios

## One Hoist

Control Type	Radio Model	Speed	# of Hoists	# of Receivers Per Kit	# of Transmitters Per Kit	Max Operating Range (ft) *	Channels	Buttons
QB4	Airmark	Two	One	1	2	1000	92	8

\* Depending on the environment

### QB4



### Airmark

Digital radio

Start Switch

Split commons

Integrated horn/alarm

Four Screw Mounting

Numbered wiring



# STEP 1 Control Types - Dual Speed Radios

## Two Hoists

Control Type	Radio Model	Speeds	# of Hoists	# of Receivers Per Kit	# of Transmitters Per Kit	Max Operating Range (ft) *	Channels	Buttons
QB5	K2	Two	Two	3	2	1000	70	8

\* Depending on the environment

### QB5



### K2

Digital radio

Start button

Split commons

Integrated horn/alarm

Jammed button detection

Button switch for A/B Both

One button set for controlling two hoist

Single post mounting

Numbered wiring

## Two Hoists

Control Type	Radio Model	Speeds	# of Hoists	# of Receivers Per Kit	# of Transmitters Per Kit	Max Operating Range (ft) *	Channels	Buttons
QB6	K3	Two	Two	3	2	1000	70	12

\* Depending on the environment

### QB6



### K3

Digital Radio

Start button

Split commons

Integrated horn/alarm

Jammed button detection

Toggle switch for A/B Both control

Visual indication of A/B Both control

Advanced two hoist button mapping available\*

Single post mounting







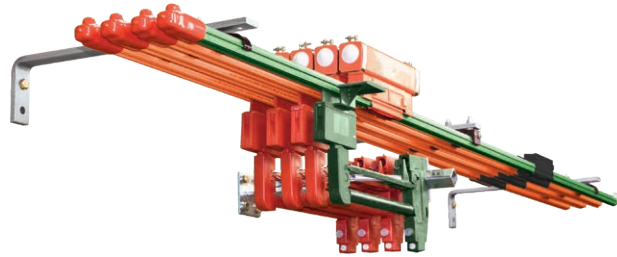

Numbered wiring

\* Contact factory for details

# STEP 2 Bar or Rail Type

## Safe-Lec 2 Conductor Bar



	Description	Notes
	Phase Bar	Each system includes 14.7 foot (4.5 meter) long phase and ground bars for three-phase power. Quantity based on system length. Splice joints are mounted to one end of the bar.
	Ground Bar	
	Joint Cover	One per splice joint. Quantity based on system length.
	Anchor Assembly	Each system includes four anchors, with plated hardware.
	End Cover	Each system includes four insulated end caps; to be installed at the ends of the conductor rail.
	End Powerfeed	Each system includes four end power feeds. Maximum cable connection size is 6 AWG (16 mm).
	Phase Collector	Each system includes three tandem phase and one tandem ground collectors, for a four pole system. Quantity based on the number of hoists per system.
	Ground Collector	
	Tow Bar	Each system includes a double-post, plated steel, tow bar. Quantity based on number of hoists per system.



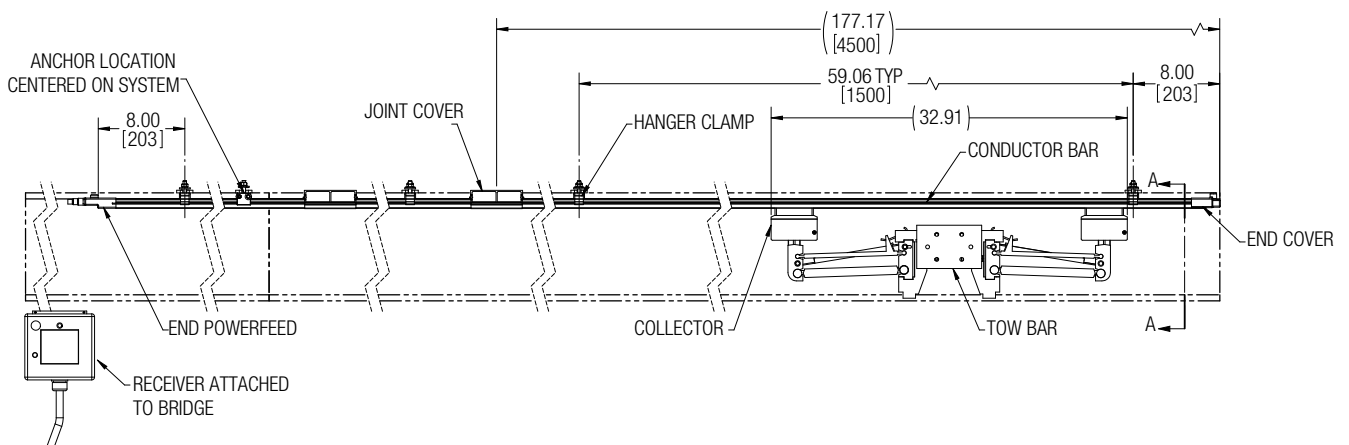



### Side View





## 842 Series BoxLine







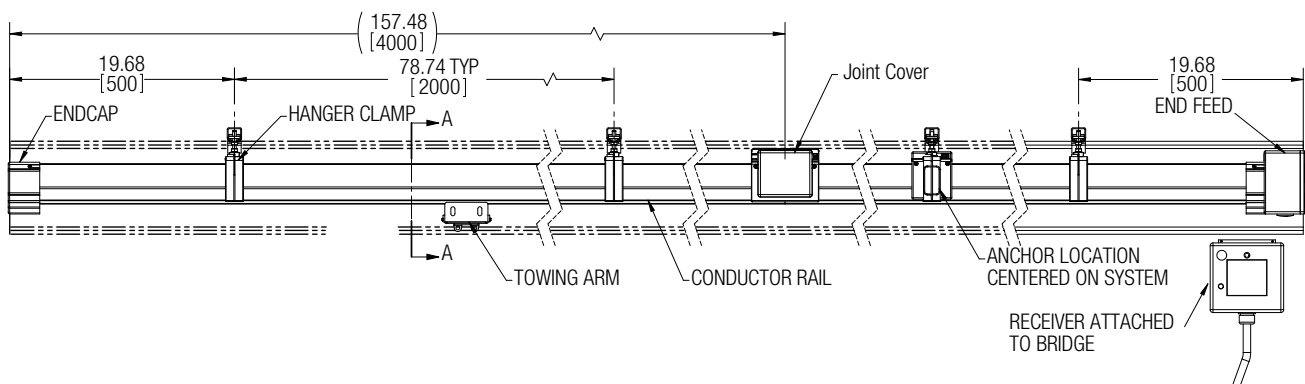

Component	Description	Notes
	Enclosed Rail Angle Clamping type	Each system includes four-pole enclosed BoxLine rails for three phase power, in either 10 ft or 13 ft sections. Quantity based on system length.
	Joint Cover	One splice joint per rail length included. Quantity based on system length.
	Anchor Assembly	One anchor included per system; with plated hardware.
	End Cover	One insulated end cap included; to be installed at the end of the enclosed conductor rail.
	End Powerfeed	One end power feed included per system. Maximum cable connection size is 6 AWG (16 mm).
	Collector Assembly	One or two tandem four pole collector assembly included; based on number of hoists used.
	Towing Assembly	One or two galvanized steel tow assemblies included per system; based on number of hoists used.

### Side View



# STEP 3 Mounting Bracket Type

Mounting Type	Description	Bar System	System Includes:	Bracket*		
				Illustration	Beam to Hanger	Length
WS	Web Brackets, Short	Safe-Lec 2 Only	10.25" long plated steel Web Brackets, with four pole gang hanger. Quantity based on 59" spacing and overall system length.		Varies	10.25"
WL	Web Brackets, Long	Safe-Lec 2 Only	15.75" long plated steel Web Brackets, with four pole gang hanger. Quantity based on 59" spacing and overall system length.		10.75" or 12.50"	15.75"
FS	Flange Brackets, Short	Safe-Lec 2 Only	15.85" long plated steel Flange Brackets, with four pole gang hanger and girder clips for mounting. Quantity based on 59" spacing and overall system length.		Varies	15.85"
FL	Flange Brackets, Long	Safe-Lec 2 Only	21.85" long plated steel Flange Brackets, with four pole gang hanger and girder clips for mounting. Quantity based on 59" spacing and overall system length.		Varies	21.85"
LT	Lateral Mount Brackets	Safe-Lec 2 Only	Plated steel Lateral Mount Brackets, with four pole gang hanger. Quantity based on 44.3" spacing and overall system length.		2.4" or 4.1"	3.75"
CA	Cross Arm Support Brackets	842 Series Only	Galvanized steel C-Channel cross arm support, with steel square nut hanger and girder clips for mounting. Quantity based on 9.8 ft spacing and overall system length.		Varies	26.60"
NB	No Mounting Brackets	Both	Bar hangers, but no brackets. Quantity and type of hangers dependent on Bar/Rail Type, required spacing, and overall system length.	None	N/A	N/A

\* See Safe-Lec 2 and 842 Series catalogs for additional detailed drawings of brackets.

## Safe-Lec 2 End View - Standard Hanger Clamps

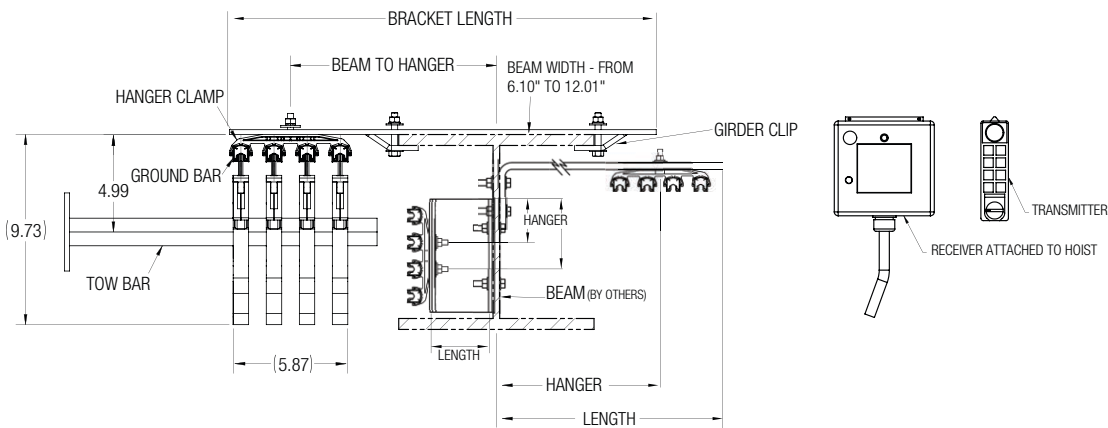

## System 842 End View - Standard Hanger Clamps

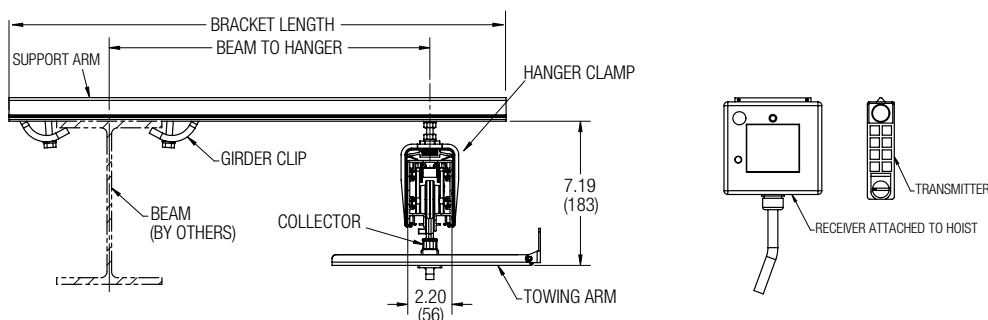

# STEP 4 System Length

## Bridge Length

System Length Designation	System Length (ft)	Maximum Current Capacity (amps) *	
		100 Amp Safe-Lec 2 Bar	60 Amp 842 Rail
030	30	100	60
040	40	100	60
050	50	100	60
060	60	99	60
070	70	85	60
080	80	74	60
090	90	66	60
100	100	59	60
110	110	54	60
120	120	49	60

\* Maximum current capacity per system length is based on:

- 480 volt 3 phase 60 Hz
- Maximum 2% voltage drop for bridge cranes, as recommended by the CMAA (Crane Manufacturers Association of America)
- 100% Duty cycle at a maximum ambient temperature of 95°F (35°C)
- 0.90 load power factor
- End power feed location

## Custom Solutions

If your application requires customized solutions, please contact Conductix-Wampfler. We have an extensive array of product solutions and options. Let our experienced team help create the perfect solution for your unique application.

- Custom footprint for existing solutions
- Custom voltage/amperage needs
- Other unique design requirements

8-Bar



Hevi-Bar II



811 Series Compact Conductor Rail on the Cross Bridge



# www.conductix.us

© Conductix-Wampfler | 2024 | Subject to Technical Modifications Without Prior Notice

## Conductix-Wampfler

has just one critical mission:  
To provide you with energy and  
data transmission systems that  
will keep your operations up  
and running 24/7/365.

To contact your nearest  
sales office, please refer to:

[www.conductix.contact](http://www.conductix.contact)

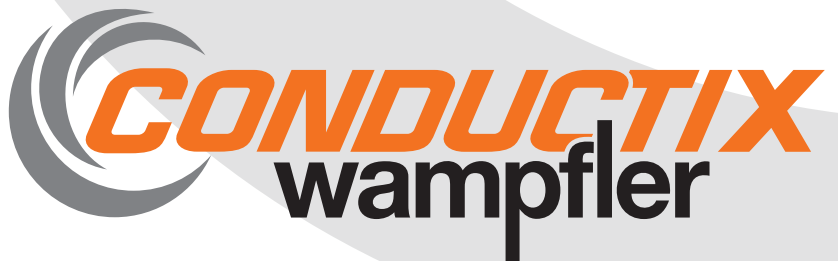

CAT1015.1-US

