

Conductor Bar Systems

Hevi-Bar II Manual

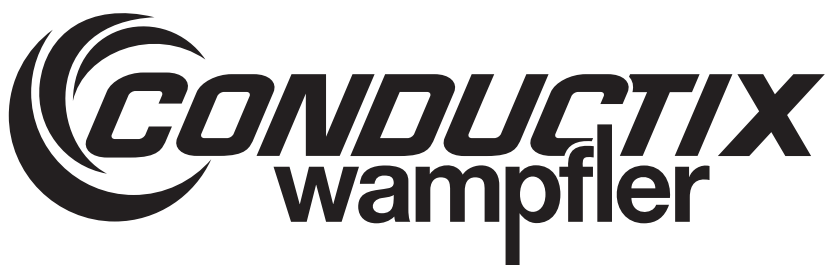
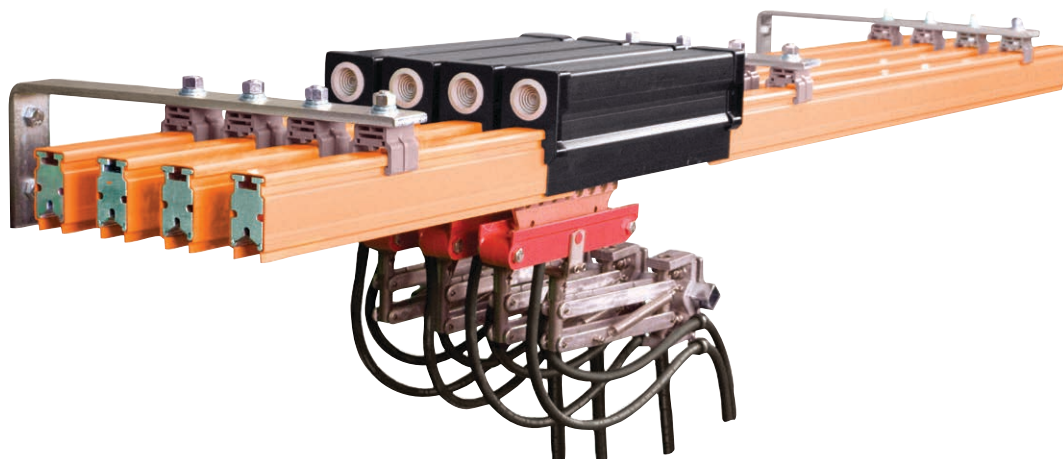

CONDUCTIX INCORPORATED

The technical data and images which appear in this manual are for informational purposes only. **NO WARRANTIES, EXPRESS OR IMPLIED, INCLUDING WARRANTIES OF MERCHANTABILITY OR FITNESS FOR A PARTICULAR PURPOSE, ARE CREATED BY THE DESCRIPTIONS AND DEPICTIONS OF THE PRODUCTS SHOWN IN THIS MANUAL.** Conductix Inc. makes no warranty (and assumes no liability) as to function of equipment or operation of systems built according to customer design or of the ability of any of its products to interface, operate or function with any portions of customer systems not provided by Conductix Inc.

Seller agrees to repair or exchange the goods sold hereunder necessitated by reason of defective workmanship and material discovered and reported to Seller within one year after shipment of such goods to Buyer.

Except where the nature of the defect is such that it is appropriate, in Seller's judgment, to effect repairs on site, Seller's obligation hereunder to remedy defects shall be limited to repairing or replacing (at Seller's option) FOB point of original shipment by Seller, any part returned to Seller at the risk and cost of Buyer. Defective parts replaced by Seller shall become the property of Seller.

Seller shall only be obligated to make such repair or replacement if the goods have been used by Buyer only in service recommended by Seller and altered only as authorized by Seller. Seller is not responsible for defects which arise from improper installation, neglect, or improper use or from normal wear and tear.

Additionally, Seller's obligation shall be limited by the manufacturer's warranty (and is not further warranted by Seller) for all parts procured from others according to published data, specifications or performance information not designed by or for Seller.

Seller further agrees to replace or at Seller's option to provide a refund of the sales price of any goods that do not conform to applicable specifications or which differ from that agreed to be supplied which non-conformity is discovered and forthwith reported to Seller within thirty (30) days after shipment to the Buyer. Seller's obligation to replace or refund the purchase price for non-conforming goods shall arise once Buyer returns such goods FOB point of original shipment by Seller at the risk and cost of Buyer. Goods replaced by Seller shall become the property of Seller.

There is no guarantee or warranty as to anything made or sold by Seller, or any services performed, except as to title and freedom from encumbrances and, except as herein expressly stated and particularly, and without limiting the foregoing, there is no guarantee or warranty, express or implied, of merchantability or of fitness for any particular purpose or against claim of infringement or the like.

Seller makes no warranty (and assumes no liability) as to function of equipment or operation of systems built to Buyer's design or of the ability of any goods to interface, operate or function with any portions of Buyer's system not provided by Seller.

Seller's liability on any claim, whether in contract, tort (including negligence), or otherwise, for any loss or damage arising out of, connected with, or resulting from the manufacture, sale, delivery, resale, repair, replacement or use of any products or services shall in no case exceed the price paid for the product or services or any part thereof which give rise to the claim. In no event shall Seller be liable for consequential, special, incidental or other damages, nor shall Seller be liable in respect of personal injury or damage to property not the subject matter hereof unless attributable to gross misconduct of Seller, which shall mean an act or omission by Seller demonstrating reckless disregard of the foreseeable consequences thereof.

Seller is not responsible for incorrect choice of models or where products are used in excess of their rated and recommended capacities and design functions or under abnormal conditions. Seller assumes no liability for loss of time, damage or injuries to property or persons resulting from the use of Seller's products. Buyer shall hold Seller harmless from all liability, claims, suits and expenses in connection with loss or damage resulting from operation of products or utilization of services, respectively, of Seller and shall defend any suit or action which might arise there from in Buyer's name - provided that Seller shall have the right to elect to defend any such suit or action for the account of Buyer. The foregoing shall be the exclusive remedies of the Buyer and all persons and entities claiming through the Buyer.

CONDUCTIX-WAMPFLER FIELD SERVICE

Need Field Service for our products? We Can Handle It!

Ask us for a quote on expert system installations, inspections, preventative maintenance, and repairs/retrofits.

As the world's largest single source manufacturer of mobile electrification products, Conductix-Wampfler has the unique ability to offer a degree of service not found anywhere else. Conductix-Wampfler's team of highly qualified service technicians and engineers have years of experience servicing our complete line of products.

We can provide:

- **Annual Service Contracts**
- **Installation**
- **Commissioning**
- **Installation supervision** to ensure your installers avoid common mistakes.
- **Troubleshooting** to get you up and running.
- **Pre-planned inspections** to complement your preventive maintenance program.

Call 1-800-521-4888 for further details.



TABLE OF CONTENTS

SECTION 1 - SAFETY	7
1.0 Safety Information Responsibility	7
1.1 Safety Messages	7
1.2 Limitation of Liability	7
1.3 Personnel Requirements-Qualifications	8
1.4 Personnel Requirements-Unauthorized Personnel	8
1.5 Personnel Requirements - Training	9
1.6 Personnel Protective Equipment	9
SECTION 2 - PRODUCT DISPOSAL	10
2.0 Product Disposal & Recycling	10
SECTION 3 - OVERVIEW	11
3.0 Hevi-Bar II Familiarization	11
3.1 Typical 3-Phase System Overview	12
3.2 Environmental Considerations	13
3.3 Installation Tools	13
SECTION 4 - GENERAL ASSEMBLY INSTRUCTIONS	14
4.0 Installation Overview	14
4.1 Identifying and Organizing the Materials	14
4.2 Installation of Brackets Along the Runway	14
4.3 Installation of Hangers and Conductors and Final Assembly Along the Runway	14-15
SECTION 5 - SUPPORT BRACKETS	16
5.0 Locations	16
5.1 Tools Needed	16
5.2 Support Bracket Installation	16
5.2.1 Bolting the Bracket in Place	16
5.2.2 Welding the Bracket in Place	16
SECTION 6 - HANGER CLAMPS	17
6.0 Locations	17
6.1 Tools Needed	17
6.2 Hanger Clamp Kit Contents	17
6.3 Hanger Clamp Installation	17
SECTION 7 - ANCHOR CLAMPS	18
7.0 Purpose and Function	18
7.1 Locations	18
7.2 Tools Needed	18
7.3 Optional Tools (Not Required)	18
7.4 Anchor Pin Installation	18
7.5 Anchor Clamp Installation	18
SECTION 8 - CONDUCTOR BARS	19
8.0 Locations	19
8.1 Tools Needed	19
8.2 Conductor Bar Kit Contents	19
8.3 Conductor Installation	19-20

TABLE OF CONTENTS

SECTION 9 - SPLICE ASSEMBLY KITS	21
9.0 Locations	21
9.1 Tools Needed	21
9.2 Splice Kit Contents	21
9.3 Installation	21
SECTION 10 - EXPANSION SECTION KITS	22
10.0 Locations	22
10.1 Tools Needed	22
10.2 Expansion Assembly Kits Contents	22
10.3 Installation	22-23
SECTION 11 - POWER FEED ASSEMBLY KITS	24
11.0 Locations	24
11.1 Tools Needed	24
11.2 Power Feed Kit Contents	24
11.3 500 Amp Installation	24-25
11.4 700 Amp / 1000 Amp / 1500 Amp Installation	26
SECTION 12 - POWER INTERRUPTING SECTION KITS	27
12.0 Locations	27
12.1 Tools Needed	27
12.2 Power Interrupting Assembly Kits Contents	27
12.3 Installation	27-29
SECTION 13 - STRONG BACK ASSEMBLIES	30
13.0 Locations	30
13.1 Tools Needed	30
13.2 Strong Back Assemblies Contents	30
13.3 Installation	30
SECTION 14 - COLLECTORS	31
14.0 Locations	31
14.1 Tools Needed	31
14.2 Collector Kit Contents	31
14.3 Installation	31
14.4 Leveling Spring Installation for Lateral Mount Collectors Overview	31
14.5 Installation	32-36

TABLE OF CONTENTS

SECTION 15 - STANDARD HEAT END COVER KITS	37
15.0 500 Amp	37
15.0.1 Locations	37
15.0.2 Tools Needed	37
15.0.3 End Cover Kits Contents	37
15.0.4 Installation	37
15.1 700 Amp	37
15.1.1 Locations	37
15.1.2 Tools Needed	37
15.1.3 End Cover Kits Contents	37
15.1.4 Installation	37
15.2 1000 Amp / 1500 Amp	38
15.2.1 Locations	38
15.2.2 Tools Needed	38
15.2.3 End Cover Kits Contents	38
15.2.4 Installation	38
SECTION 16 - HIGH HEAT END COVER KITS	39
16.0 700 Amp	39
16.0.1 Locations	39
16.0.2 Tools Needed	39
16.0.3 End Cover Kits Contents	39
16.0.4 Installation	39
16.1 1000 Amp	40
16.1.1 Locations	40
16.1.2 Tools Needed	40
16.1.3 End Cover Kits Contents	40
16.1.4 Installation Needed	40
SECTION 17 - INSPECTION AND MAINTENANCE	41
17.0 Overview	41
17.1 Frequency	41
17.2 Covers	41
17.3 Hanger Clamps	41
17.4 Conductors	41
17.5 Splices	42
17.6 Anchor Clamps	42
17.7 Expansions	42
17.8 Power Feeds	42
17.9 End Caps	42
17.10 Collectors	42-43
17.10.1 Collector Arms	42
17.10.2 Mounting Brackets and Bolts	42
17.10.3 Tension Springs	42
17.10.4 Spring Pins	43
17.10.5 Cables	43
17.11 Shoe Holders	43
17.12 Collector Shoe Replacement	44
SECTION 18 - TROUBLESHOOTING	45-46
NOTES	47

SECTION 1 - SAFETY

1.0 Safety Information Responsibility

- 1.0.1 All owner, operator, and maintenance personnel must read and understand all manuals associated with this product before installation, operation, or maintenance.
- 1.0.2 The manual provides information on the recommended installation, operation, and maintenance of this product. Failure to read and follow the information provided could cause harm to yourself or others and/or cause product damage. No one should install, operate, or attempt maintenance of this product prior to familiarizing themselves with the information in this manual.

1.1 Safety Messages

The following safety messages are used in this manual to alert you to specific and important safety related information.

CAUTION

CAUTION indicates unsafe actions or situations that have the potential to cause injury, and/or minor equipment or property damage.

DANGER

DANGER indicates hazards that have the potential to cause severe personal injury or death.

WARNING

WARNING indicates unsafe actions or situations that have the potential to cause severe injury, death, and/or major equipment or property damage.

NOTE

NOTE is used to alert you to installation, operation, programming, or maintenance information that is important, but not hazard related.

1.2 Limitation of Liability

- 1.2.1 All data and information in this mounting instructions have been compiled in compliance with the applicable standards and regulations, best practice and our many years of experience and knowledge.
- 1.2.2 The manufacturer accepts no liability for damages resulting from:
- Failure to comply with this document
 - Improper use
 - Use by untrained personnel
 - Unauthorized modifications
 - Technical changes
 - Use of unauthorized replacement parts and accessories
 - The actual scope of delivery may differ from the explanations and descriptions provided here if the model in question is a special one, if additional equipped has been ordered or due to recent technical changes.
- 1.2.3 The obligations agreed upon in the delivery agreement and our General Terms and Conditions of business apply, as do the delivery conditions of the manufacturer and the legal regulations applicable at the time the contract was concluded.
- 1.2.4 All products are subject to technical modifications in the context of improvement of function and further development.

SECTION 1 - SAFETY

1.3. Personnel Requirements-Qualifications

WARNING

Inadequately trained persons are at risk of injury!

Improper use can result in serious personal injury or material damage. All activities must only be performed by qualified personnel.

1.3.1 Only persons who can be expected to perform their work reliably are acceptable personnel. People whose reactions are impaired by drugs, alcohol or medications, for example, are not authorized.

1.3.2 When selecting personnel, follow all age- and occupation-specific guidelines applicable at the location of use.

1.3.3 The following qualifications are specified in the operating instructions for certain fields of activity.

1.3.4 Trained personnel and operators

- Will have participated in a training session, given by the owner, on the tasks assigned to them and the potential hazards in case of improper conduct.
- The owner of the machine or system must document that the appropriate training has taken place.

1.3.5 Specialist personnel

- Will consist of persons capable of performing assigned tasks and independently identifying and avoiding potential hazards based on their specialist training, knowledge and experience as well as their knowledge of the applicable regulations. Persons are deemed to be technically qualified if they have successfully completed training as a master electrician, apprentice electrician, electrical engineer or electrical technician. Persons are also considered technically qualified if they have been employed in an appropriate capacity for several years, receiving theoretical and practical training in that line, and their knowledge and skills have been tested by a specialist in the appropriate field of training.
- The machine or system owner must document that the appropriate certificates or other proofs of qualification have been or are being provided.

1.4 Personnel Requirements-Unauthorized Personnel

WARNING

Danger due to unauthorized personnel!

Unauthorized persons who do not meet the requirements described here are not acquainted with the dangers in the working area. Keep unauthorized personnel away from the working area. In case of doubt, address the person and direct them away from the working area. Stop working, as long as unauthorized persons are in the working area.

SECTION 1 - SAFETY

1.5 Personnel Requirements-Training

1.5.1 Before commissioning the equipment, personnel must be trained by the owner. Log the implementation of training for better traceability.

Example of a training log:

Date	Name	Training Type	Training Instructor	Signature
11/5/2019	John Doe	First safety training for personnel	Dave Miller	

1.6 Personal Protective Equipment

1.6.1 For every task, always use:

Safety helmet: For protection against falling or flying parts and materials.

Protective gloves: For the protection of hands against friction, scrapes, puncture or deeper wounds, as well as against contact with hot surfaces.

Protective work clothing: Primarily for protection against entrapment by moving machine parts. Work clothing must be close fitting with a low resistance to tearing; it must have close-fitting sleeves and no protruding parts.

Protective footwear: For protection against heavy falling parts and slipping on slippery floors.
For special tasks, specific protective equipment is required when executing particular tasks:

Safety eye wear: For eye protection against harmful influences such as strong light, chemicals, dust, splinters or weather effects.

Hearing protection: For protection against loud noises and to prevent acoustic trauma.

Breathing mask (FFP-3 - according to country-specific requirements): For protection against materials, particles, and organisms. In this case, for protection against the dust produced by the abrasion of carbon brushes and the PVC insulation of the conductor rail.

SECTION 2 - PRODUCT DISPOSAL

2.0 Product Disposal and Recycling

2.0.1 Once the product has reached its end of life it must be disassembled and disposed of in accordance with local and regional environmental requirements.

2.0.2 In the absence of a return and disposal agreement, disassembled components must be recycled as follows:

- All metallic parts must be sorted and recycled by material type
- All plastic components must be sorted and recycled by material type
- All other components are to be disposed of in accordance with their material composition. Take care with items identified as Substances of Concern.

2.0.3 Local authorities or special disposal companies can provide information about environmentally appropriate disposal.

SECTION 3 - OVERVIEW

3.0 Hevi-Bar II Familiarization

- 3.0.1 All personnel working on the conductor system should be familiar with this manual and regional, local, and install site health and safety standards, the guide way, the components, and the component location on the guide way.
- 3.0.2 To avoid problems during installation, the installer's personnel must become familiar with the notes on the component drawings. The drawings serve to identify the components and include notes on installation with torque values for fasteners. In the event of a conflict or question over installation procedure between the manual and the drawings, the drawing shall take precedence.
- 3.0.3 Due to the nature of this product as an electric conductor, all connections are critical. Mating surfaces must be cleaned of dirt and debris and aluminum oxide must be removed. Aluminum when exposed to air, builds up an oxide on the surface. This oxide is high in resistance. If the oxide is not removed prior to assembling the components, such as a splice, the current flow through the conductor system will be inhibited. It is critical that the resistance remain low for proper system performance. To remove the oxide, a wire brush must be used to clean all mating aluminum surfaces. Immediately after the oxide is removed, Aluma-Shield or Noalox oxide inhibiting grease must be applied to the surface and then the components bolted together. The oxide inhibiting grease prevents oxide buildup and provides low-resistant connection.
- 3.0.4 Hevi-Bar II can be used indoor or outdoor with insulated hangers. The operating temperature range is -40°F to +250°F (up to +280°F with high-heat covers on 700A and 1000A Conductors Only).

SECTION 3 - OVERVIEW

3.1 Typical 3-Phase System Overview

**Example of 4 Conductor Runway
Hevi-Bar II
(3 Phase + 1 Ground)**

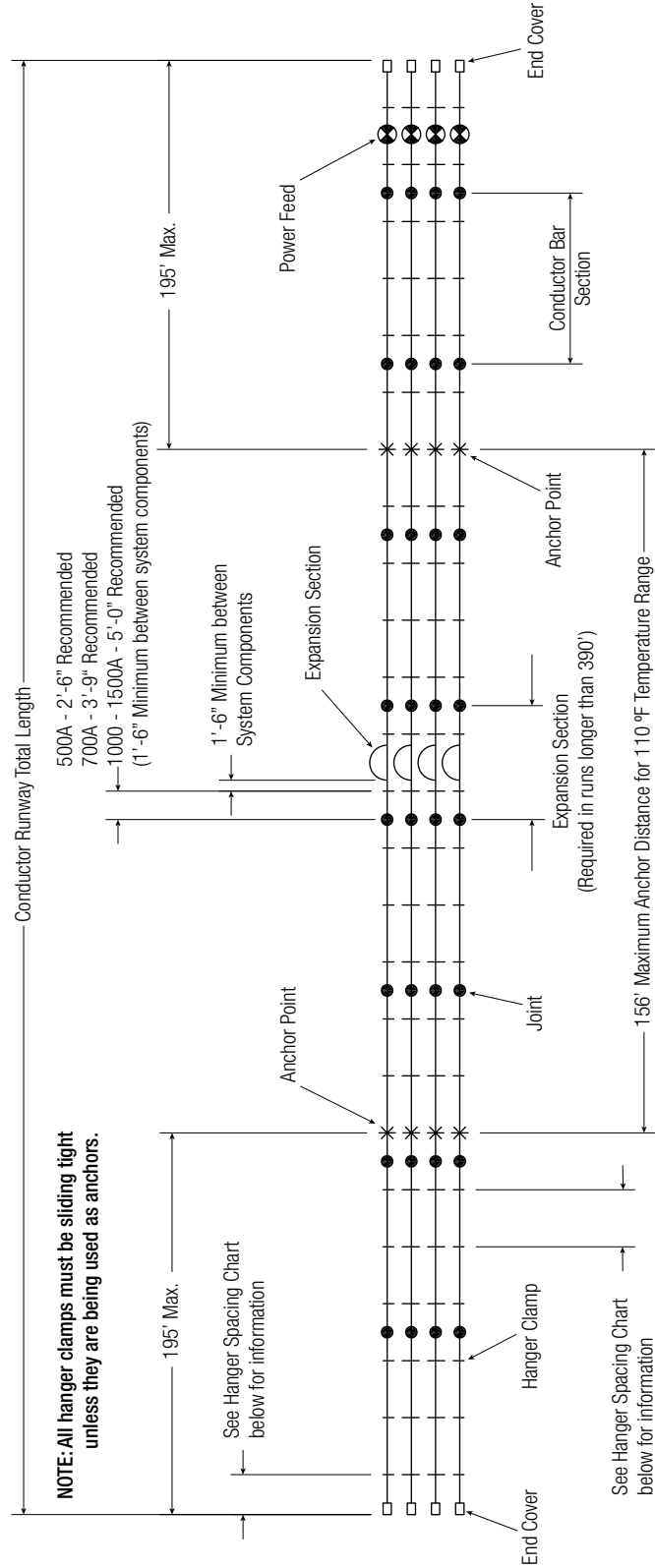

Hanger Spacing Chart

System	First Hanger	Maximum Hanger Spacing
500 Amp	2'-6"	5'-0"
700 Amp	3'-9"	7'-6"
1000 Amp	5'-0"	10'-0"
1500 Amp	5'-0"	10'-0"

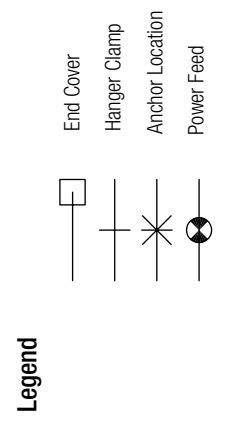

SECTION 3 - OVERVIEW

3.2 Environmental Considerations

- Standard Cover (PVC) is suitable up to 160°F.
- Medium Heat Cover (Polycarbonate) is suitable up to 250°F.
- High Heat Cover (Glass Filled Polyester) is suitable up to 280°F.

NOTE:The following acidic or corrosive environments require the use of stainless steel hangers:

- Hydrochloric Acid
- Hydrofluoric Acid
- Sodium Hydrochloride
- Ammonium Chloride
- Chlorine Bleach
- Chloride Ions
- Fluoride Ions

3.3 Installation Tools

- Man lift or platform lift for access to the installation location (if required)
- A power drill, with drill bits ranging from 1/4" to 3/4", depending on system
- A hammer, to tap in anchor pins
- Two torque wrenches: one for ground use and one for runway level use. 7/16" to 3/4", and 16 mm sockets depending on system
- Two wire brushes, ground, and runway level
- Linoleum knife
- A measuring tape
- Scotch Brite Pads (or equivalent) to clean mating surfaces of bar
- Open end/box end combination 3/8", 7/16", 1/2", 9/16", and 16 mm wrenches

SECTION 4 - GENERAL ASSEMBLY INSTRUCTIONS

WARNING

Always lock out/tag out all electrical power before starting work.

4.0 Installation Overview

4.0.1 This manual provides detailed instructions in the general order of system installation.

4.0.2 System installation consists of 4 phases:

1. Identifying and Organizing the Materials
2. Installation of Brackets Along the Runway
3. Pre-Install Assemblies on the Ground
4. Installation of Hangers and Conductors and Final Assembly Along the Runway

4.1 Identifying and Organizing the Materials

4.1.1 Check the pack list against the items received. Parts are labeled for your convenience. Review your specific installation layout drawing (if provided) or the typical layout diagram provided in this booklet to become familiar with the component location on the system. Note where the anchors, expansions, power feeds, and other assemblies will be located along the runway. Read through these instructions before starting work.

NOTE:

- Make sure to check for smaller components that may be located inside the false bottom of the package.
- Do not remove shipping supports from expansion sections or power interrupting sections until they have been installed on the runway.

4.2 Installation of Brackets Along the Runway

4.2.1 Install brackets as shown in Section 5 - Support Brackets. Keep them as level and evenly spaced as possible. You may install the hangers on the brackets before or after they are mounted along the runway.

4.2.2 Assemble as much as possible on the ground. It's faster, easier, safer, and more convenient should you drop something.

1. Install end caps on the end conductors, keeping them separated from the main runway conductors.
2. Install isolation splices (if included) on the ends of the conductors in accordance with the installation layout drawing and the instructions found in the booklet.
3. Install transfer caps on the conductor ends (if included) per this booklet.

4.3 Installation of Hangers and Conductors and Final Assembly Along the Runway

4.3.1 Final installation along the runway will most likely be accomplished from a lift or work platform.

WARNING

Always lock out/tag out all electrical power before starting work.

1. Install the hangers, per this booklet.
2. Roll adjacent conductors into the hangers as shown in Section 8 - Conductor Bars. Follow the steps for the specific hanger that is being used, either snap in or cross bolt.
3. Conductix-Wampfler recommends the first accessible conductor being the ground conductor (if applicable).
4. Move down the runway, install the next inboard conductor and join it to the corresponding conductor installed in step 2.
5. Install the splice cover. Keep the splice assemblies at least 18.0" from the hanger brackets to allow for conductor movement from

SECTION 4 - GENERAL ASSEMBLY INSTRUCTIONS

- expansion. Repeat for the remaining phases and ground conductors.
- When you get to where the expansion assemblies are to be installed, refer to the instructions found in Section 8 - Expansion Section Kits.
 - Ensure the expansion assembly body is at least 18" from the nearest bracket.
 - If a conductor must be cut to a specific length, ensure that the cut end is square +/- 1 degree and properly de-burred.

NOTE:

- The conductor cover is always shorter than bar length. See Figure 4-1.
- When you run the feed cable to the power feed assembly, ensure the cables have sufficient free length and are flexible enough to enable movement of the conductor due to expansion. Locating the power feed as close as possible to the anchors minimizes this concern. Do not support the weight of the feed cables with the conductors.
 - Install power feeds on conductor bars per layout and the instructions in **Section 11 - Power Feed Assembly Kits**.

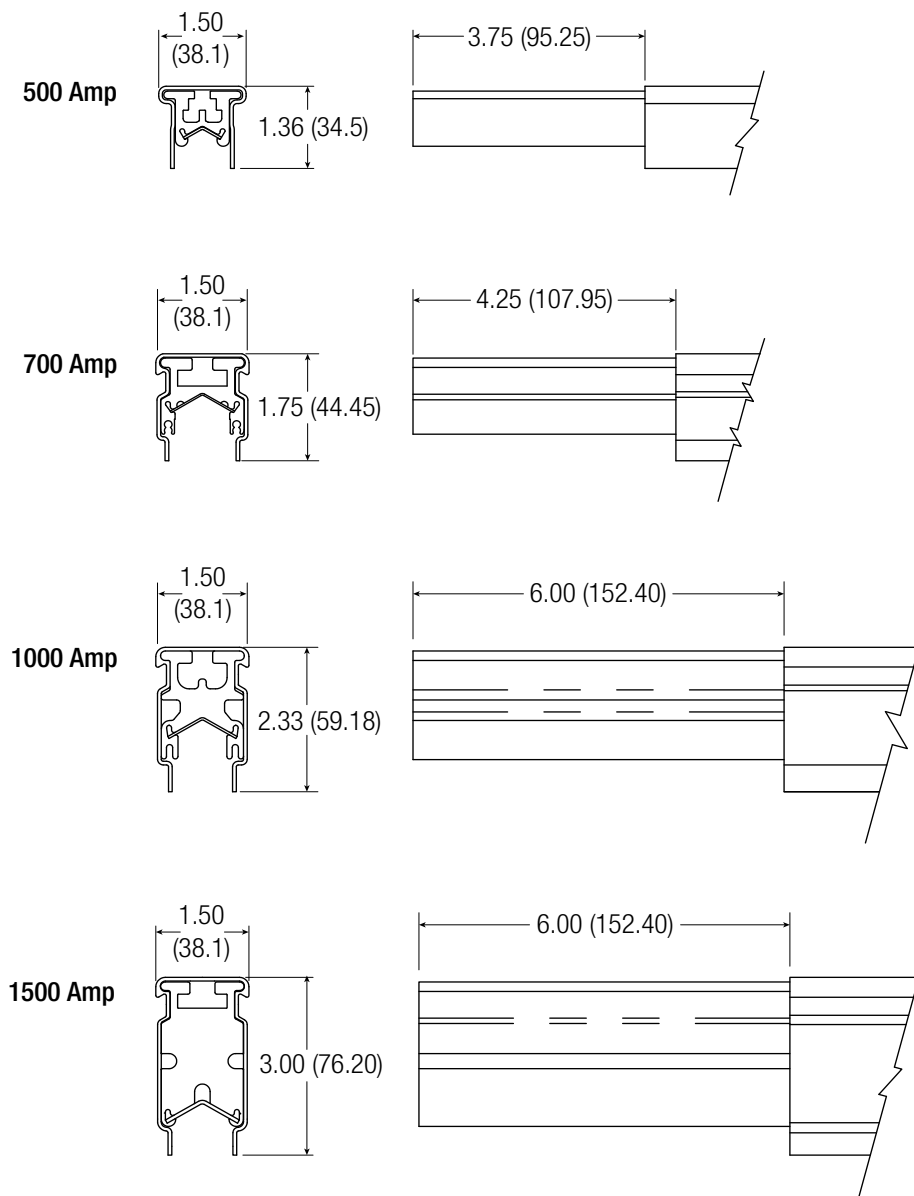

Figure 4-1

SECTION 5 - SUPPORT BRACKETS

5.0 Locations

5.0.1 Support brackets may be web, flange, brace web, or lateral. A drawing of each bracket can be seen in **Figure 5-1** to **Figure 5-4**. The brackets are located at a maximum distance of 5 feet on a 500A system, 7.5 feet on a 700A system, and 10.0 feet on a 1000A-1500A system.

5.1 Tools Needed

- Drive torque wrench with standard sockets
- Welder (optional)

5.2 Support Bracket Installation

5.2.1 For ease of installation pre-install hangers to brackets on the ground following the steps described in **Section 6 - Hanger Clamps**.

5.2.2 When mounting web brackets, take special care in aligning the brackets at precisely the same height as to assure level travel of the system.

5.2.3 Web brackets may be mounted by bolting the bracket to the support structure or by welding the bracket in place.

5.2.1 Bolting the Bracket in Place

1. Drill 2 (two) 0.531" holes that match the mounting pattern of the web bracket being used.
2. Use 1/2" Grade 5 or higher hardware to mount the web bracket.
3. Place 1/2" bolt with washer on through the web bracket and I-beam hole with the bolt head on the web bracket side.
4. Place a 1/2" flat washer, lock-washer, and then nut on the bolt and tighten to 40 ft-lbs. (52.8 N-m).
5. Repeat for all mounting holes on web bracket.

5.2.2 Welding the Bracket in Place

1. To weld the web bracket to the support structure simply position the web bracket and tack weld to the beam.
2. After ensuring that the bracket is mounted at the correct height and level, proceed to fillet weld the bracket to the support structure.

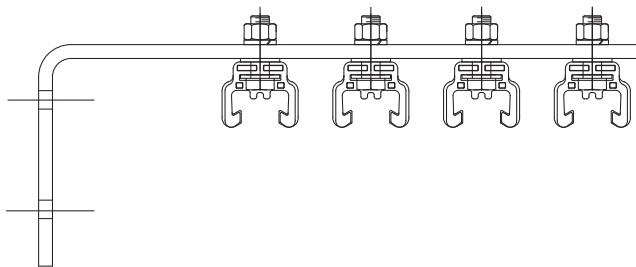

Figure 5-1

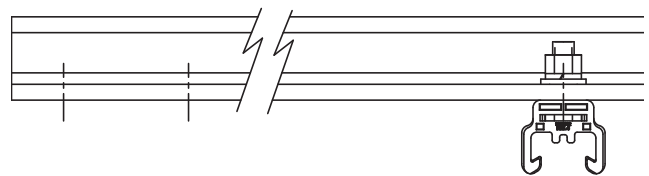

Figure 5-2

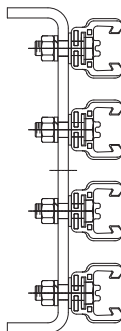

Figure 5-3

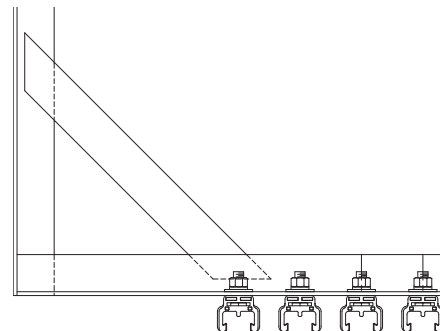

Figure 5-4

SECTION 6 - HANGER CLAMPS

6.0 Locations

6.0.1 Hanger clamps are located at a maximum of 5 feet for 500A conductor bar, 7.5 feet for 700A conductor bar, and 10 feet for 1000 and 1500A conductor bar.

6.1 Tools Needed

- Drive torque wrench with standard sockets
- Welder (when mounting hanger directly to structure or when unable to use fasteners)

6.2 Hanger Clamp Kits Contents

- Hanger clamp body, bolts, washers, and lock washers. A reference drawing for both cross-bolt and snap-in hanger clamps can be seen in **Figure 6-1**.

6.3 Hanger Clamp Installation

6.3.1 Hanger clamps are most easily installed on brackets while on the ground, before the brackets are mounted to the runway.

1. Set the 1/2" hex-bolt head into the hole inside the top of the hanger clamp.
2. Place the bolt through the mounting hole on the bracket.
3. Attach a flat washer, lock washer, and nut and then torque to required value specified in **Table 6-2**.
4. Weld or bolt brackets into place on the runway after checking to make sure that no splices will occur closer than 18 inches to a support bracket.
5. For systems using hanger clamps with cross bolts, tighten the nuts on the hanger clamp until .02 to .05 inch clearance remains between the hanger clamp and the conductor bar.

NOTE:

- When using cross-bolt hangers they should not be tightened all the way. Doing so will prevent movement of the bar during thermal expansion and contraction causing the conductors to bind/snake, possibly causing damage to the system.

6.3.2 A drawing is shown below of the proper installation of each type of hanger clamp, snap-in or cross bolt, that is offered (conductor bar is shown only as a reference).

6.3.3 The distance from the bottom of the mounting surface to the contact surface of the bar is shown in **Table 6-1**.

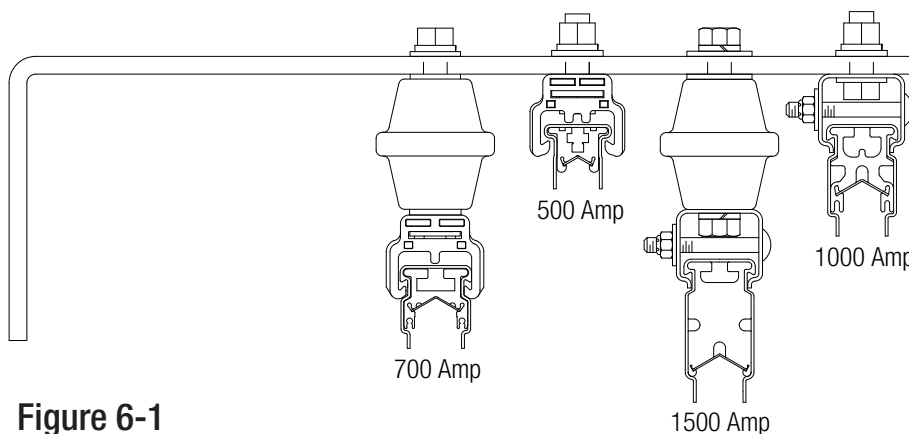

Figure 6-1

System	Distance to Contact Surface	With Insulator
500 Amp	1.63"	4.50"
700 Amp	1.75"	4.63"
1000 Amp	2.25"	5.13"
1500 Amp	3.13"	6.00"

Table 6-1

Hanger Type	Bolt Torque Specification
Polycarbonate Snap-In	15 ft-lbs.
Polycarbonate Snap-In w/ insulator	25-26 ft-lbs.
Stainless Steel Cross Bolt	38-39 ft-lbs.
Stainless Steel Cross Bolt w insulator	25-26 ft-lbs.

Table 6-2

SECTION 7 - ANCHOR CLAMPS

7.0 Purpose and Function

7.0.1 Anchor clamps control the expansion movement of the conductors. They fix or anchor the conductor to brackets at specified points along the runway.

WARNING

Failure to properly install and locate the anchors could result in system malfunction and/or damage to the system components.

7.1 Locations

7.1.1 The first anchor point is nominally placed no more than 195 feet from the starting end, and succeeding anchor points will be made no more than 156 feet (distances will vary depending upon total system length and temperature range). These values are based on 110°F maximum temperature change. For a different temperature change please consult the factory.

7.2 Tools Needed

- A power drill with a 0.247" or machinist "D" size drill bit
- A hammer
- RTV silicone
- 1/4" pin punch

7.3 Optional Tools (Not Required)

- For 500A bar (for use with snap-in-hanger clamps only) use drill fixture, PN XA-29855.
- For 700/1000/1500A bar (for use with snap-in hanger clamps only) use drill fixture, PN XA-30033.

7.4 Anchor Pin Installation

1. Mount anchor clamp to brackets using the same steps for mounting hanger clamps found in this manual.
2. Drill two (2) 0.247" (size "D") holes through the conductor rail and cover. Drill these holes as straight as possible, parallel to the top of the rail. See Figure 7-1.
3. Use anchor pin punch to insert the anchor pins through the conductor rail.
4. If pins are not a forced fit, an RTV type compound must be used to insure pin is properly secure and cannot fall out.

7.5 Anchor Clamp Installation

1. For systems using hanger clamps with cross bolts, torque the nuts on the hanger clamp to 60 in.-lbs at anchor locations only. Anchor pins are not required.

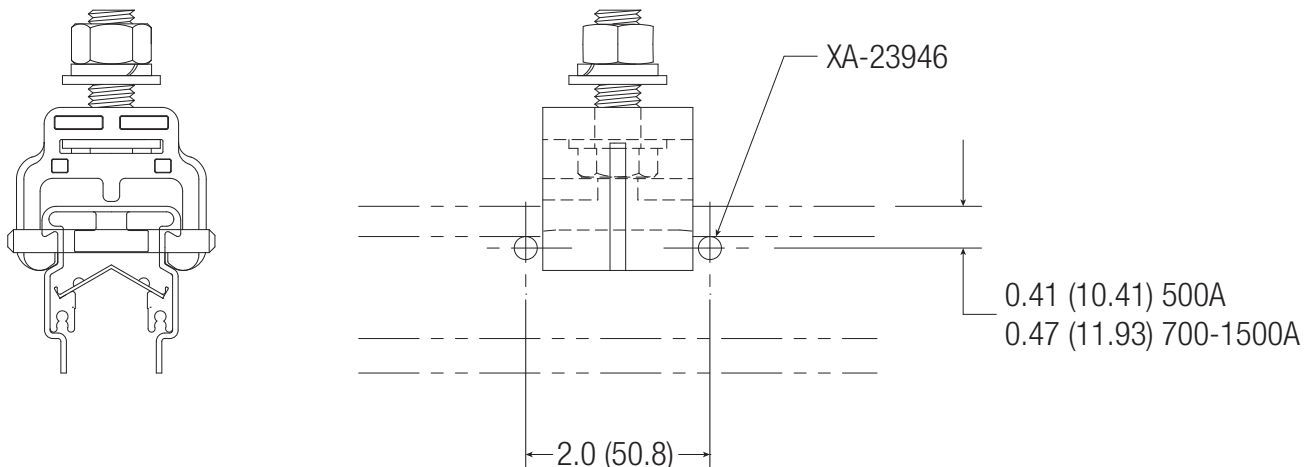

Figure 7-1

SECTION 8 - CONDUCTOR BARS

8.0 Locations

8.0.1 Conductor bar spans the length of the entire system except where there are gaps in the span for the power interrupt sections and expansions.

8.1 Tools Needed

- Drive torque wrench with standard sockets
- Scotch Brite Pads (or equivalent) to clean mating surfaces of bars

8.2 Conductor Bar Kits Contents

- Conductor bar with insulating cover

8.3 Conductor Installation

8.3.1 Conductor bar is delivered from the factory with cover pre-installed. For information on installing cover over power feed connections, Power Interrupt Sections, and splice assemblies, please see the respective sections in this manual.

8.3.2 After brackets with hanger clamps are in place, installation of the bar may begin. Start at one end of the runway and work toward the other end.

1. Clean the contact surfaces with a Scotch Brite Pad or fine wire brush. See **Table 8-1** for distance.

NOTE:

- If conductor has DURA-COAT, the surface must have all the coating removed before joint compound can be applied.
2. Apply electrical joint compound (**XA-15629**) on cleaned contact surfaces.
 3. Slide 3 bolt heads into the slot on the top of the bar and put the splice plate over the bolts.
 4. Attach washer and nut, and tighten. **DO NOT OVER TORQUE!**
 5. One half of the splice plate, exposing three bolt holes, should be extended off the end of the conductor bar.
 6. With three people at runway level (insure safety of the installers and proper handling of the conductor), raise the first bar up to position. It is best to hoist 30ft. lengths with three ropes.
 7. Install the first section in the clamps nearest the web of the beam. One person should be handling the bar at each hanger clamp location.

System	Distance Application for End of Bar
500 Amp	3.00" (76.2)
700 Amp	4.00" (101.6)
1000 Amp	5.25"
1500 Amp	5.25"

Table 8-1

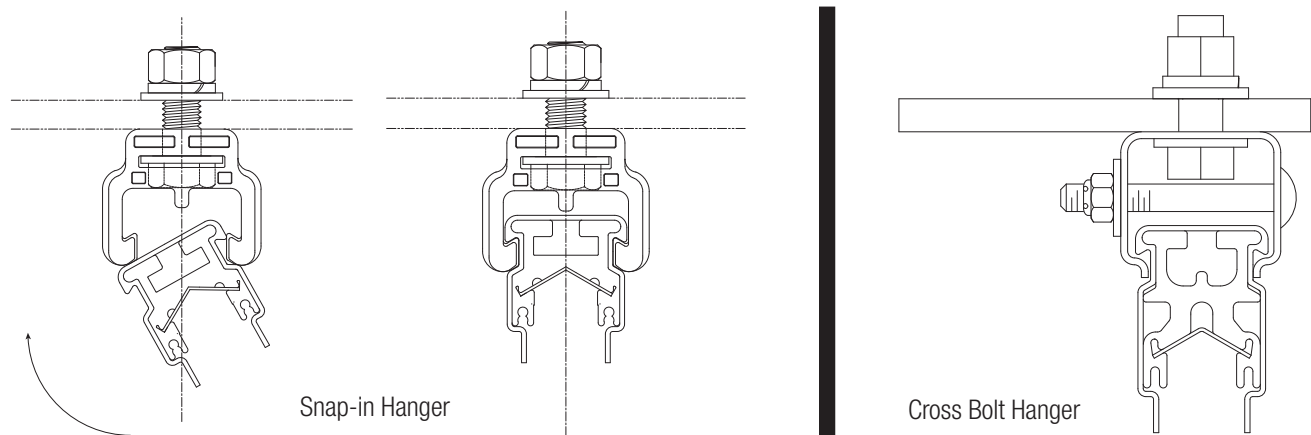

Figure 8-1

SECTION 8 - CONDUCTOR BARS

8. Insert one lip of the covered bar into the clamp. Firmly rotate bar until it snaps firmly into the other lip clamp. **See Figure 8-1.**
9. For systems using hanger clamps with cross bolts, tighten the nuts on the hanger clamp until .02 to .05 inch clearance remains between the hanger clamp and the conductor bar. Do not over-tighten cross bolts on hangers.
10. Continue the same procedure for each phase of adjacent conductor bars.
11. The 30 foot length of bar is now suspended in a minimum of 3 clamps. It is recommended that you snug each bar to 1 clamp with duct tape or a nylon tie TEMPORARILY, so that as you splice on successive bars down the runway you will not jar the first bars from their proper position. Hang a brightly colored streamer from the tie so that you will be reminded to come back and remove it as soon as you have installed the first set of anchors.
12. The bar and clamps have now been "seated". Tighten the nut on the top of each clamp to the specified torque value in **Table 8-2** below. **DO NOT OVER TORQUE.**
13. Check clamps to see that they have not rotated and that they are still square with the bar.

Hanger Type	Bolt Torque Specification
Polycarbonate Snap-In	15 ft-lbs.
Polycarbonate Snap-In w/ insulator	25-26 ft-lbs.
Stainless Steel Cross Bolt	38-39 ft-lbs.
Stainless Steel Cross Bolt w insulator	25-26 ft-lbs.

Table 8-2

SECTION 9 - SPLICE ASSEMBLY KITS

9.0 Locations

9.0.1 Splice assemblies are used to join 2 pieces of bar together. They provide an electrical and mechanical connection.

9.1 Tools Needed

- Drive torque wrench with standard sockets
- Cable tie gun to tighten and cut cable ties
- Scotch Brite Pads (or equivalent) to clean mating surfaces of bars
- Electrical joint compound

9.2 Splice Kits Contents

- Aluminum splice plate, bolts, washers, nuts, cover, end caps and EJC (electrical joint compound).
- An example of a completed splice assembly is shown below in **Figure 9-1**.

9.3 Installation

1. You are now ready to install the second set of bars and make the first splice connection. If assembly has end caps slide end caps onto conductor bar far enough away to leave room to work. We recommend you purchase additional splice kits for use during installation in case of dropping or misplacing any of the parts and pieces
2. Before splices can be assembled onto the conductor bar the mating surfaces of the conductor and splice need to be cleaned with Scotch Brite Pad (or equivalent).

NOTE:

If conductor has DURA-COAT, the surface must have all the coating removed before joint compound can be applied.

3. Apply joint compound to the top of the conductor bar end for approximately half of the splice length, and to the bottom of the splice plate. Apply joint compound to top surface of the second bar where splice plate will attach.
4. Slide 3 bolts into the slot in second bar, ease the bar downward slightly and slide the bar up to the next bar until bars butt together.
5. Maneuver the 3 bolts through the holes in the splice plate, attach washer and nut, and tighten to 6 ft-lbs. torque for 500 amp bar, 11 ft-lbs. for 700A-1500A. **DO NOT OVER TORQUE.**
6. Slide end plugs (if assembly has end plugs) onto conductor bars. Place overlap cover into position, centered over splice plate. Snap end plugs into the holes in the overlap cover. Ensure end plugs are seated correctly..

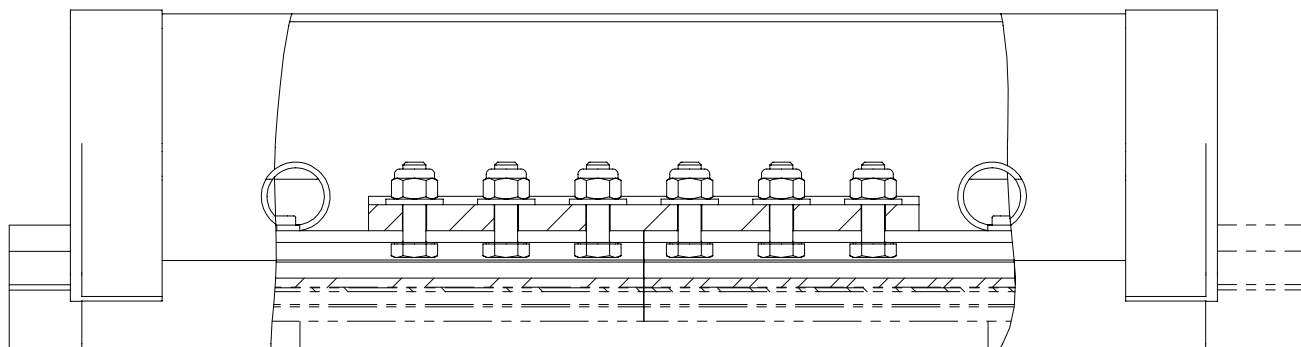

Figure 9-1

SECTION 10 - EXPANSION SECTION KITS

10.0 Locations

10.0.1 Expansion assembly position, location and length of expansion sections vary depending on rail and temperature range of product will be in. Please consult factory for proper placement in your system. It is required that an expansion assembly be used if the span of the system exceeds 390 feet.

10.1 Tools Needed

- Drive torque wrench with standard sockets
- Scotch Brite Pads (or equivalent) to clean mating surfaces of bars
- Electrical joint compound

10.2 Expansion Assembly Kits Contents

- Conductor bar, conductor bar cover, slider assembly, overlap cover, and end plugs. A drawing of a 500A expansion assembly can be seen below in **Figure 10-1**.

NOTE:

- Do not remove all shipping hardware until ready to set the gap. The hardware will keep the expansion from getting damaged during shipment.

10.3 Installation

1. Clean all surfaces to be joined with Scotch Brite Pads and apply electrical joint compound (XA-15629) to all mating surfaces.
2. Use same procedures for joint compound and splice plates on expansion sections as with standard bar section.
3. Install expansion section into clamps using same procedures as with standard bar. Use extra care as to not twist this section.
4. When conductor run has reached the next anchor point, adjust expansion gap. The gap setting is determined by **Table: 10-1**. This table assumes a Maximum Temperature Range of 110°F. The gap between conductors is determined by the ambient temperature at the time of installation.
5. After the gap has been set, anchor the conductor.

NOTE:

- For other temperature ranges see installation drawings or consult factory for gap settings.

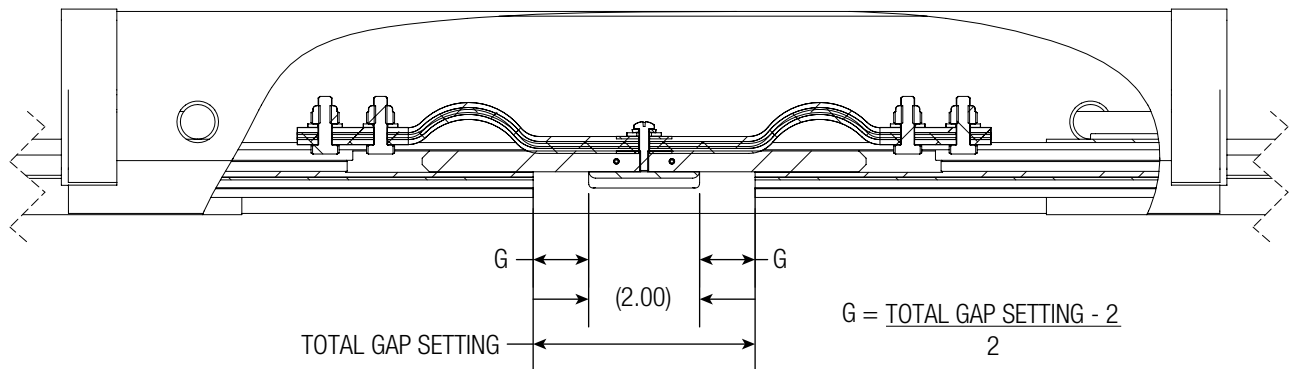

Figure 10-1

SECTION 10 - EXPANSION SECTION KITS

		Actual Site Ambient Temperature, °F (°C)																										
		-10 (-23.3)	0 (-17.8)	10 (-12.2)	20 (-6.7)	30 (-1.1)	40 (4.4)	50 (10)	60 (15.6)	70 (21.1)	80 (26.7)	90 (32.2)	100 (37.8)	110 (43.3)	120 (48.9)	130 (54.4)	140 (60)	150 (65.6)	160 (71.1)									
Lowest Possible Site Ambient Temperature, °F (°C) See Note	130 (54.4)																6.00 (152.4)	5.64 (143.2)	5.27 (133.9)	4.91 (124.7)								
	120 (48.9)																6.00 (152.4)	5.64 (143.2)	5.27 (133.9)	4.91 (124.7)	4.55 (115.5)							
	110 (43.3)																6.00 (152.4)	5.64 (143.2)	5.27 (133.9)	4.91 (124.7)	4.55 (115.5)	4.18 (106.2)						
	100 (37.8)																6.00 (152.4)	5.64 (143.2)	5.27 (133.9)	4.91 (124.7)	4.55 (115.5)	4.18 (106.2)	3.82 (97)					
	90 (32.2)																6.00 (152.4)	5.64 (143.2)	5.27 (133.9)	4.91 (124.7)	4.55 (115.5)	4.18 (106.2)	3.82 (97)	3.45 (87.7)				
	80 (26.7)																6.00 (152.4)	5.64 (143.2)	5.27 (133.9)	4.91 (124.7)	4.55 (115.5)	4.18 (106.2)	3.82 (97)	3.45 (87.7)	3.09 (78.5)			
	70 (21.1)																6.00 (152.4)	5.64 (143.2)	5.27 (133.9)	4.91 (124.7)	4.55 (115.5)	4.18 (106.2)	3.82 (97)	3.45 (87.7)	3.09 (78.5)	2.73 (69.3)		
	60 (15.6)																6.00 (152.4)	5.64 (143.2)	5.27 (133.9)	4.91 (124.7)	4.55 (115.5)	4.18 (106.2)	3.82 (97)	3.45 (87.7)	3.09 (78.5)	2.73 (69.3)	2.36 (60)	
	50 (10)																6.00 (152.4)	5.64 (143.2)	5.27 (133.9)	4.91 (124.7)	4.55 (115.5)	4.18 (106.2)	3.82 (97)	3.45 (87.7)	3.09 (78.5)	2.73 (69.3)	2.36 (60)	2.00 (50.8)
	40 (4.4)																6.00 (152.4)	5.64 (143.2)	5.27 (133.9)	4.91 (124.7)	4.55 (115.5)	4.18 (106.2)	3.82 (97)	3.45 (87.7)	3.09 (78.5)	2.73 (69.3)	2.36 (60)	2.00 (50.8)
	30 (-1.1)																6.00 (152.4)	5.64 (143.2)	5.27 (133.9)	4.91 (124.7)	4.55 (115.5)	4.18 (106.2)	3.82 (97)	3.45 (87.7)	3.09 (78.5)	2.73 (69.3)	2.36 (60)	2.00 (50.8)
	20 (-6.7)																6.00 (152.4)	5.64 (143.2)	5.27 (133.9)	4.91 (124.7)	4.55 (115.5)	4.18 (106.2)	3.82 (97)	3.45 (87.7)	3.09 (78.5)	2.73 (69.3)	2.36 (60)	2.00 (50.8)
	10 (-12.2)																6.00 (152.4)	5.64 (143.2)	5.27 (133.9)	4.91 (124.7)	4.55 (115.5)	4.18 (106.2)	3.82 (97)	3.45 (87.7)	3.09 (78.5)	2.73 (69.3)	2.36 (60)	2.00 (50.8)
	0 (-17.8)																6.00 (152.4)	5.64 (143.2)	5.27 (133.9)	4.91 (124.7)	4.55 (115.5)	4.18 (106.2)	3.82 (97)	3.45 (87.7)	3.09 (78.5)	2.73 (69.3)	2.36 (60)	2.00 (50.8)
	-10 (-23.3)																6.00 (152.4)	5.64 (143.2)	5.27 (133.9)	4.91 (124.7)	4.55 (115.5)	4.18 (106.2)	3.82 (97)	3.45 (87.7)	3.09 (78.5)	2.73 (69.3)	2.36 (60)	2.00 (50.8)

Total Gap Setting, in. (mm)

Table 10-1

SECTION 11 - POWER FEED ASSEMBLY KITS

11.0 Locations

11.0.1 Power feed assemblies are typically installed in the center of a system, but can be placed anywhere along the system depending upon voltage drop, characteristics, and feed cable location. A minimum distance of 1-1/2 ft. to other components must be maintained.

11.0.2 Cable sizes range from 2/0 to 350 MCM for 500A and 2/0 to 500 MCM for 700A/1000A/1500A. Cable must be welding cable or as flexible as welding cable. Cable and lugs are to be supplied by customer.

11.1 Tools Needed

- Drive torque wrench with standard sockets
- Scotch Brite Pads (or equivalent) to clean mating surfaces of bars
- Electrical Joint Compound

11.2 Power Feed Kits Contents

- Power feed plate, bolts, washers, nuts, and insulating cover

NOTE:

- Cable and lug are to be supplied by the customer.
- For Maximum allowable cable diameter see **Table 11-1**.

11.3 500A Installation

1. If assembly has end plugs (refer to drawing supplied with power feed kits), slide end plugs onto conductor bar far enough away to leave room to work.
2. Cut top of cover to length (shown on installation instructions sent with power feed kit) where power feed is to be installed.
3. If conductor is DURA-COATED, coating must be removed prior to assembly of power feed plate.
4. Drill and deburr a 1/2" hole in the center of the slot in the top of the conductor (do not drill past slot).
5. Drop bolts head first into hole and slide into position.
6. If assembly has end plugs, cut grommet to accept feeder cable (1.25" max.), install in end plug, and insert power cable through grommet.
7. Clean mating surfaces (bar, power feed plate and lug) with wire brush or Scotch Brite Pads and apply electrical joint compound to cleaned surfaces.
8. Assemble power feed plate and cable on top of conductor using hardware provided. If hardware is stainless steel apply anti-seize to end of bolts before assembly of nuts. Torque to 6 ft-lbs.
9. Snap cover (centered) over power feed cable assembly, slide end plugs (if assembly has end plugs) into power feed cover.

NOTE:

- An example of a 500 Amp power feed assembled can be seen in **Figure 11-1**.

Cover	Amperage	Max Cable Size	Part Number
Standard	500	350 MCM	XA-37674
Standard	700	500 MCM	XA-38117
Standard	1000	500 MCM	XA-38184
Standard	1500	500 MCM	XA-50227
Medium Heat	500	350 MCM	XA-32500
Medium Heat	700	500 MCM	XA-50067
Medium Heat	1000	500 MCM	XA-38184D
Medium Heat	1500	500 MCM	XA-50227C
High Heat	700	500 MCM	XA-24594
High Heat	1000	500 MCM	XA-23530

Table 11-1

SECTION 11 - POWER FEED ASSEMBLY KITS

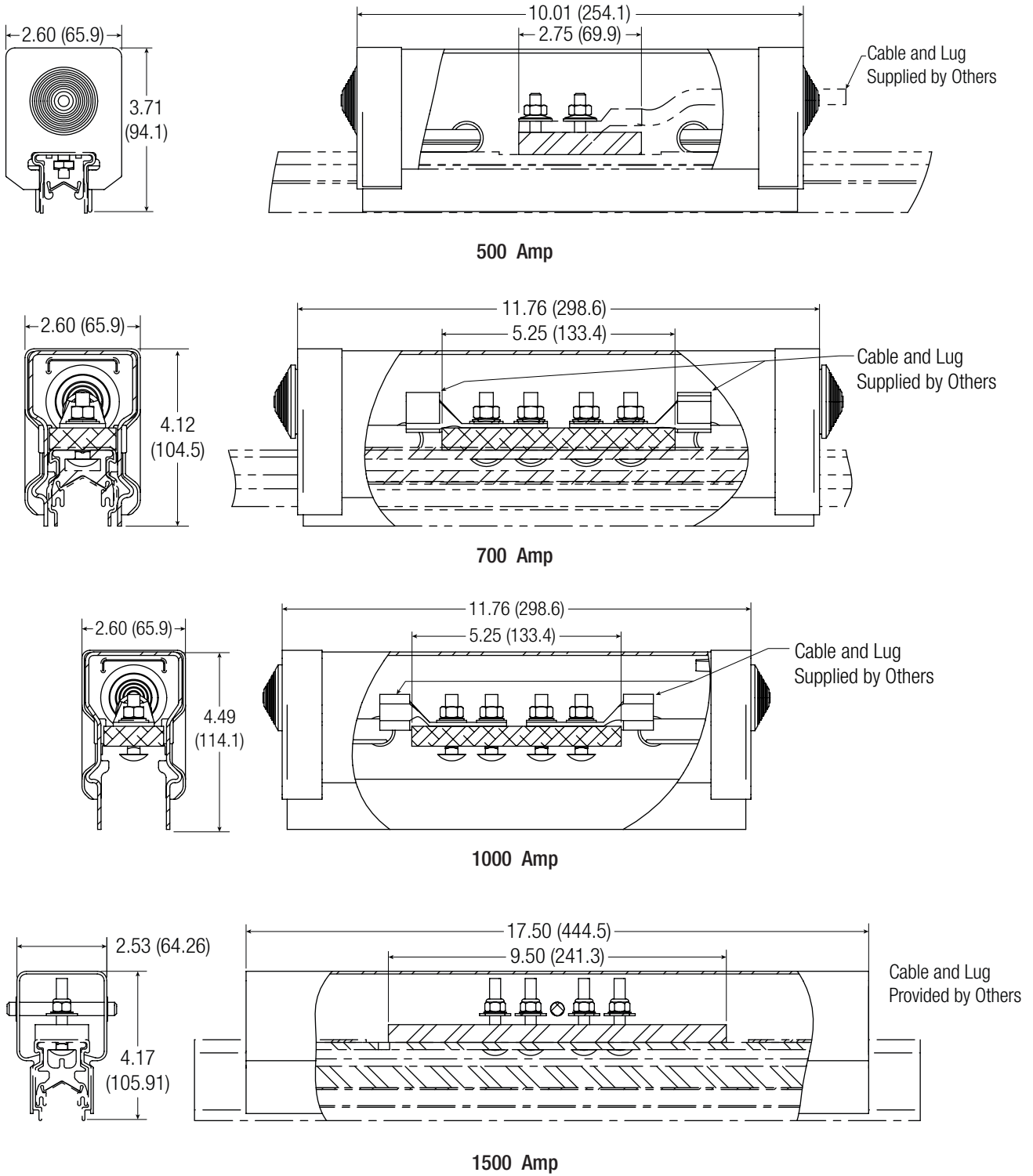

Figure 11-1

SECTION 11 - POWER FEED ASSEMBLY KITS

11.4 700A/1000A/1500A Installation

1. If assembly has end plugs (refer to drawing supplied with power feed kit), slide end plugs onto conductor bar far enough away to leave room to work.
2. Cut top of cover to length (shown on installation instructions sent with power feed kit) where power feed is to be installed.
3. If conductor is DURA-COATED, coating must be removed prior to assembly of power feed plate.
4. Drill and deburr a 3/4" hole in the center of the slot in the top of the conductor (do not drill past slot).
5. Drop carriage bolts into hole head first and slide into position.
6. If assembly has end plugs, cut grommet to accept feed cable (1.25" max.), install in end plug, and insert power cable through grommet.
7. Clean mating surfaces (bar, power feed plate, and lug) with wire brush or Scotch Brite Pads and apply electrical joint compound to cleaned surfaces.
8. Assemble power feed plate and cable on the top of conductor using hardware provided. If hardware is stainless steel apply anti-seize to end of bolts before assembly of nuts. Torque to 10-11 ft-lbs.
9. Snap cover (centered) over power feed cable assembly, slide end plugs (if assembly has end plugs) into power feed cover.

SECTION 12 - POWER INTERRUPTING SECTION KITS

12.0 Locations

12.0.1 Power interrupting section kits are used so that a single power system may be broken into two separate power sections thus allowing one side to be shut off while the other is powered.

12.1 Tools Needed

- Drive torque wrench with standard sockets
- Scotch Brite Pads (or equivalent) to clean mating surfaces of bars
- Electrical joint compound

12.2 Power Interrupting Assembly Kits Contents

- Conductor bar, conductor bar cover, disconnect section, overlap cover, and end plugs.
- A detailed drawing of a power interrupt section is shown in **Figure 12-1**. The assembly displayed has a double 1.00" air gap setting for power interruption.

12.3 Installation

1. Clean all surfaces to be joined with Scotch Brite pads and apply electrical joint compound (XA-15629) to mating surfaces.
2. Use same procedures for joint compound and splice plates on power interrupting sections as with standard bar section.
3. Install power interrupt section into clamps using same procedures as with standard bar, but while using extra care as to not twist this section.

NOTE:

- A detailed schematic can be seen in **Figure 12-2**.
- A standard air gap for isolation is 1.0", is recommended that 2.0" air gap is used for outdoor and dusty / dirty environments.

SECTION 12 - POWER INTERRUPTING SECTION KITS

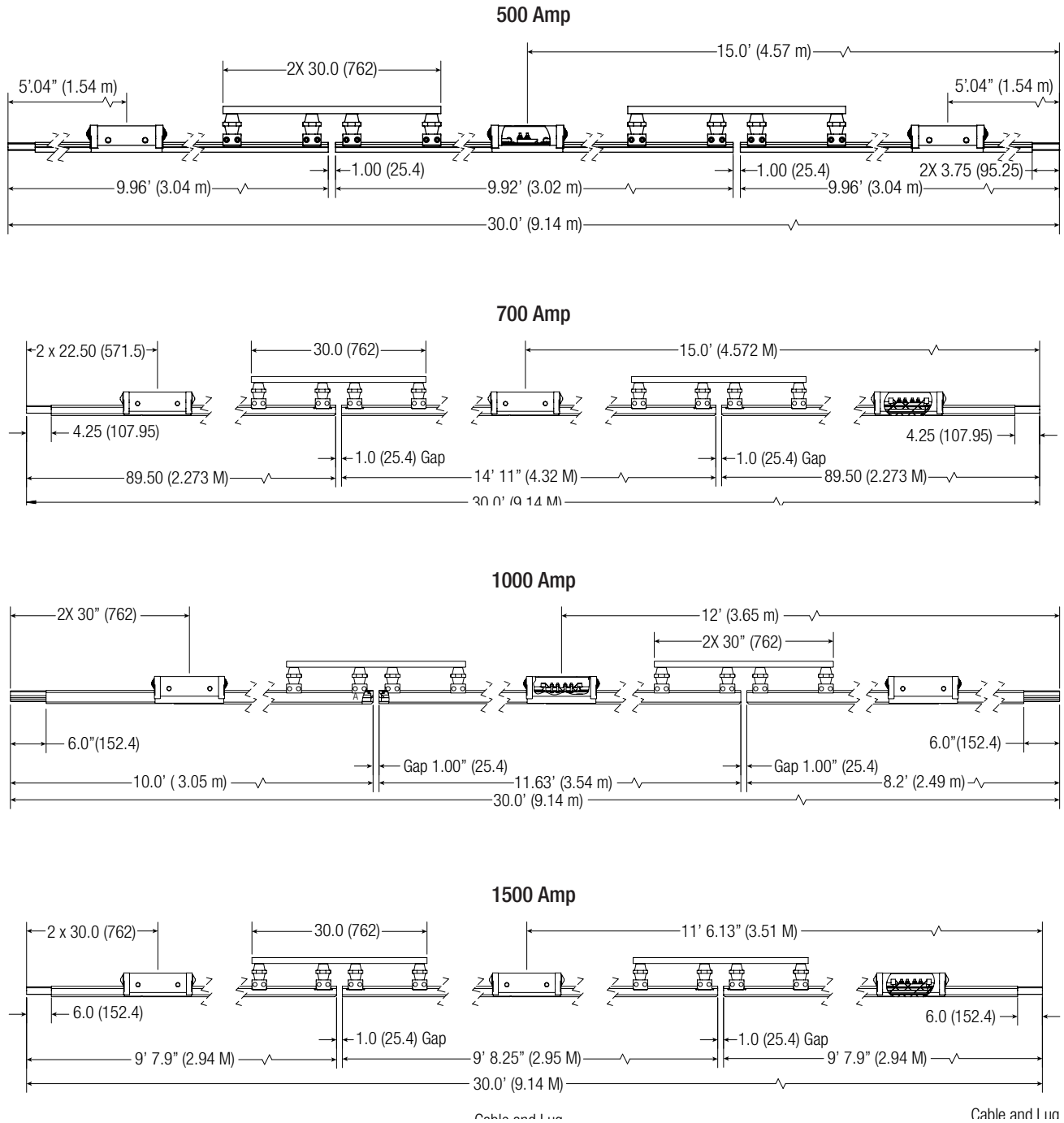
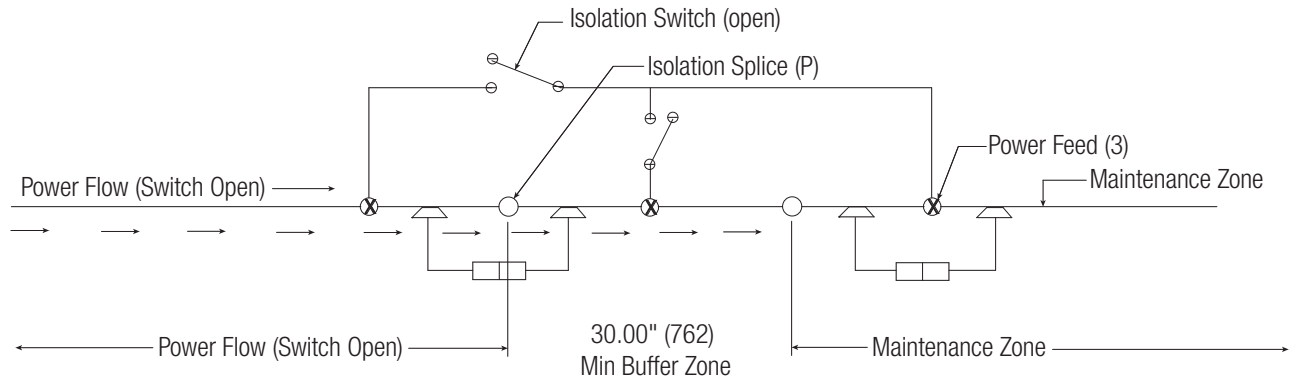

Figure 12-1

SECTION 12 - POWER INTERRUPTING SECTION KITS



***BUFFER ZONE PREVENTS BRIDGING OF POWER TO THE MAINTENANCE ZONE.**

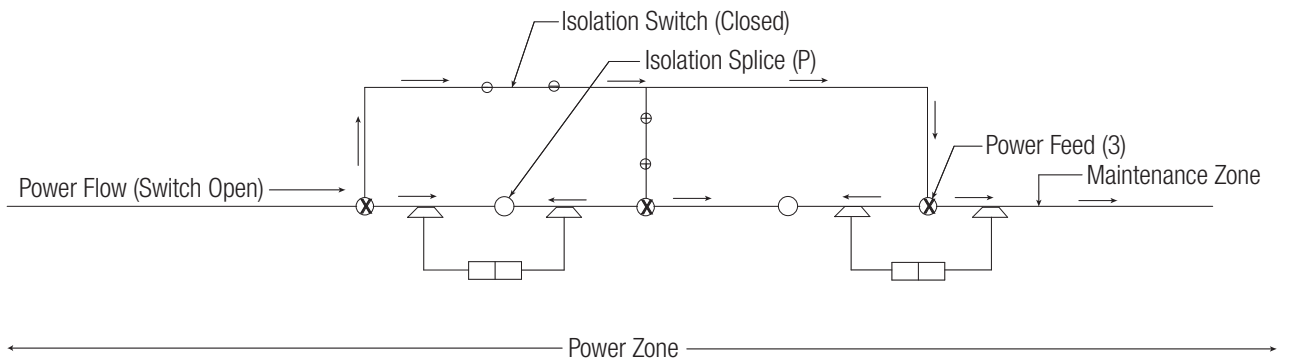
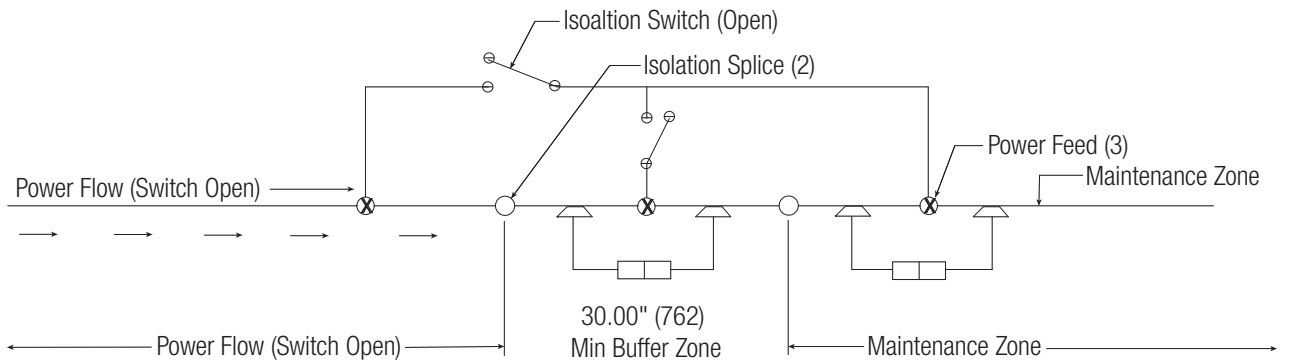

Figure 12-2

SECTION 13 - STRONG BACK ASSEMBLIES

13.0 Locations

13.0.1 Strong back assemblies are used to protect and give extra support when needed for expansion gaps, isolation sections, and power interrupting sections. See **Figure 13-1**.

13.1 Tools Needed

- Drive torque wrench with standard sockets

13.2 Strong Back Assemblies Contents

- Hanger clamps, channel for required length, and mounting hardware

13.3 Installation

13.3.1 The strong back assembly is generally factory installed before shipment. The following must be checked prior to putting the system into use.

1. The top hanger mount must be checked for a max torque of 39 ft-lbs.
2. The cross bolts will be finger tight or max torque of 5 ft-lbs, depending on placement of strong back.

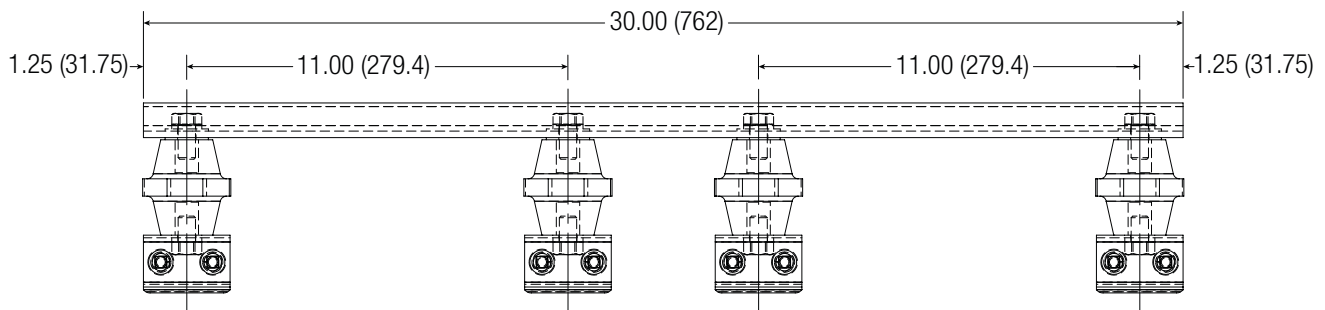

Figure 13-1

SECTION 14 - COLLECTORS

14.0 Locations

14.0.1 Collectors run the length of the system traveling along the bar supplying power to the given machine. Collectors may be run single or tandem.

14.1 Tools Needed

- Drive torque wrench with a 9/16 hex socket. Tandem collectors require a 16 mm hex socket.
- Open end/box end combination 9/16 wrench, tandem collectors require a 16 mm wrench.

14.2 Collector Kits Contents

- Collector assembly with all mounting hardware and pigtails

14.3 Installation

1. For 500A conductors, mount the 1 inch square bar so that the center line is 5.5 inches from the contact surface of the bar. For all other amperage conductors, mount the 1 inch square bar at 6 inches from the contact surface of the bar.
2. If there is any question to the mounting distance, please refer to the particular system layout drawing or consult the factory at (800) 521-4888.
3. Align the collectors on the square bar as shown in **Figure 14-9**. The typical phase-to-phase mounting distance between collectors is 3 inches. Please consult the specific layout drawing for exact values. Take special care as to align the collector arms so they run directly beneath the conductor bar. This assures maximum shoe life and permit full articulation of the collector head.
4. Fasten the collector to the 1 inch square bar by tightening the mounting nuts according to **Table 14-1. DO NOT OVER TORQUE.**

NOTE:

- For special collectors, refer to specific layout.
- For specific pigtail size **See Table 14-2.**

14.4 Leveling Spring Installation for Lateral Mount Collectors Overview

14.4.1 Install one collector at a time on the square mounting post and then install the leveling spring for that collector. If all collectors are installed before installing the springs, there is not enough space to insert the leveling springs.

14.4.1 Instructions are given looking down at the collector from above as viewed in **Figure 14-2**.

14.4.2 The body of the leveling spring is always installed on the top side of the collector so that it lifts the collector.

14.4.3 The angled end of the leveling spring is installed between the square mounting post and the mounting hardware and in the middle of the two collector bases.

14.4.4 The hook end of the spring will always wrap around the outside of the collector arms. The spring body should never be installed between the arms of the collectors.

Mounting Base Material	Torque Value
Plastic	8-10 Ft-Lbs.
Aluminum	18-20 Ft-Lbs.
Stainless Steel	18-20 Ft-Lbs.

Table 14-1

SECTION 14 - COLLECTORS

14.5 Installation

1. Install the first collector on the square mounting post. Leaving mounting hardware slightly loose to ease installation of the leveling spring.
2. For the collector on the left, insert the angled end of the leveling spring between the retaining block and collector base as shown.
3. Wrap the hook end of the spring around the outside of the bottom collector arm and hook it to the inside of the arm.
4. For the collector on the right, insert the angled end of the leveling spring between the retaining block and collector base as show.
5. Wrap the hook end of the spring around the outside of the top collector arm and hook it to the inside of the arm.
6. Tighten mounting hardware and torque to proper specifications.
7. For single collectors, the angled end of the spring is installed between the square mounting post and mounting hardware and in the middle of the collector base and back clamp.

NOTE:

- See Figures on the following pages for reference.

Amperage	Collector Part Number	Pigtail Part Number	Pigtail Gauge
500	XA-30388	XA-28063	4 AWG
700-1500	XA-24061	XA-28063H	2 AWG

Table 14-2

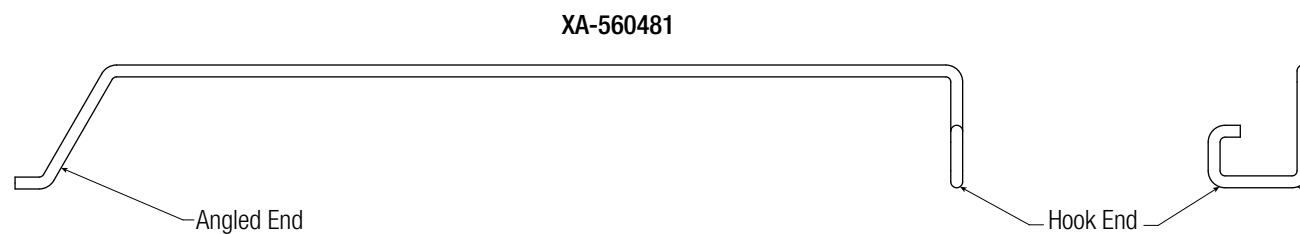

Figure 14-1

SECTION 14 - COLLECTORS

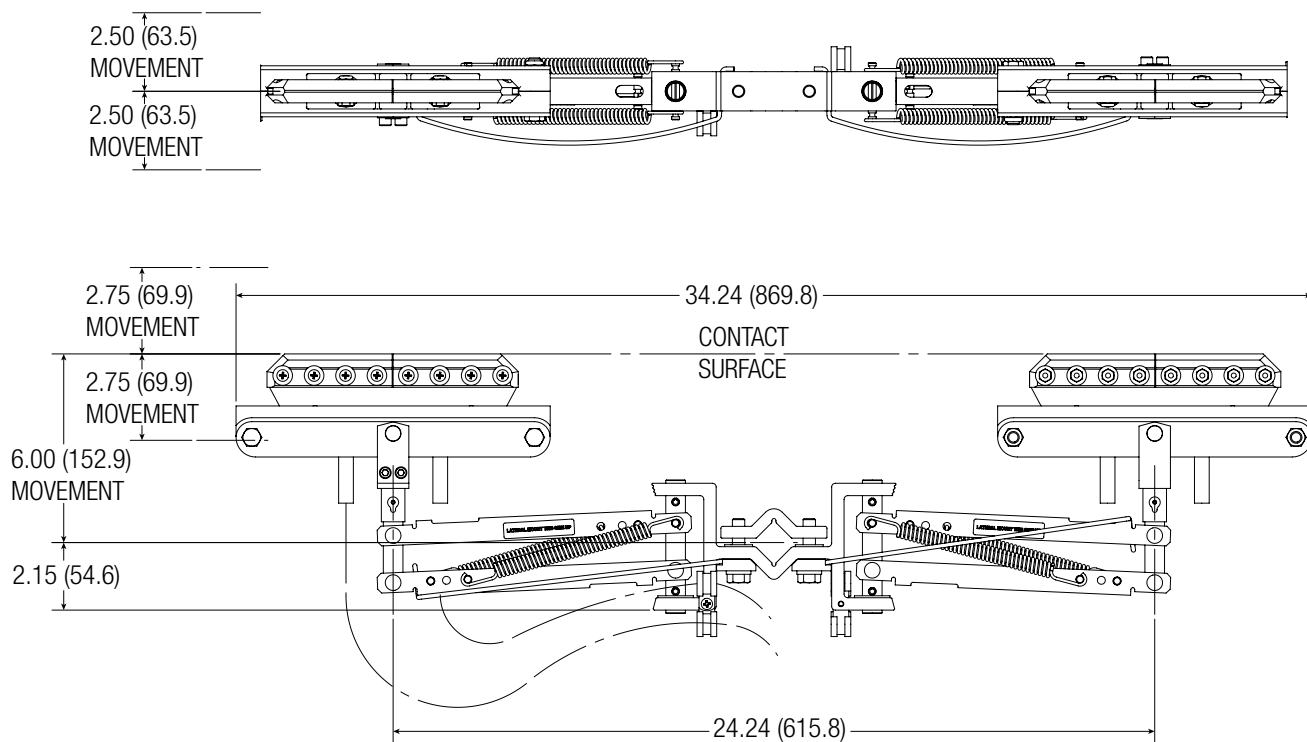

Figure 14-2 - XA-HB2C-600T-42-LATL

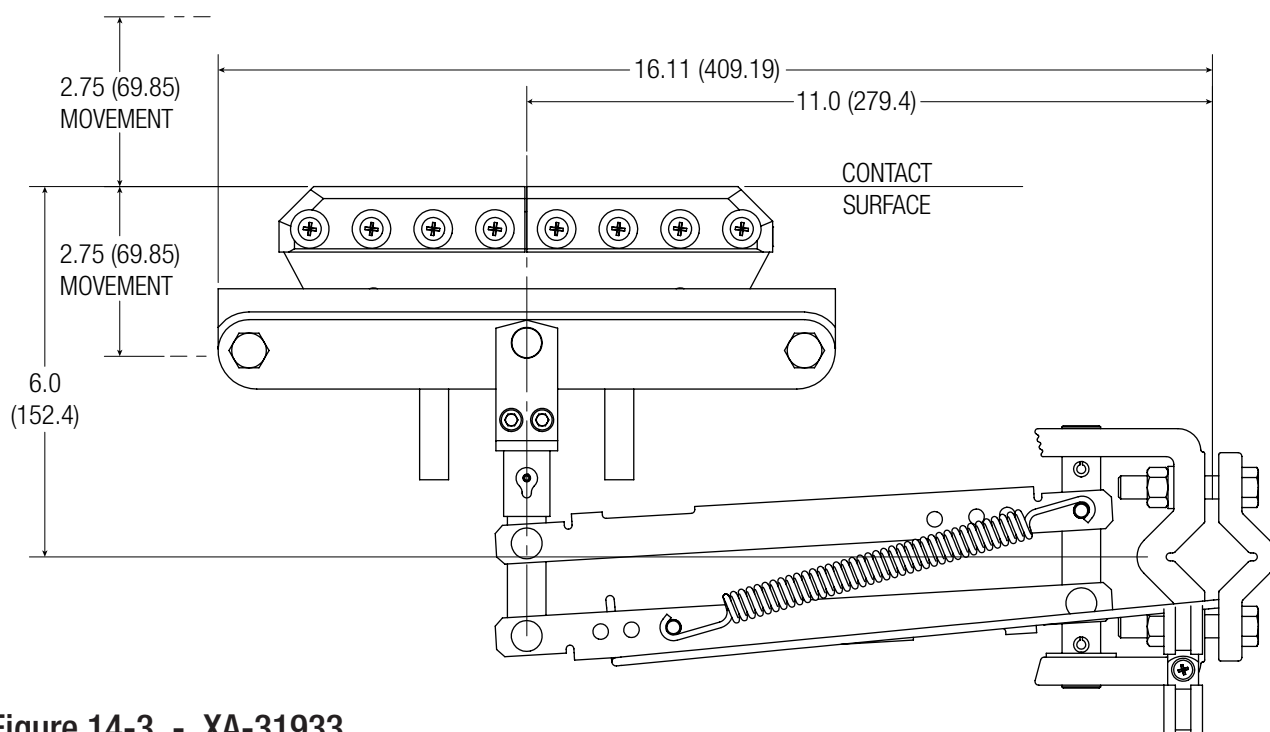

Figure 14-3 - XA-31933

SECTION 14 - COLLECTORS

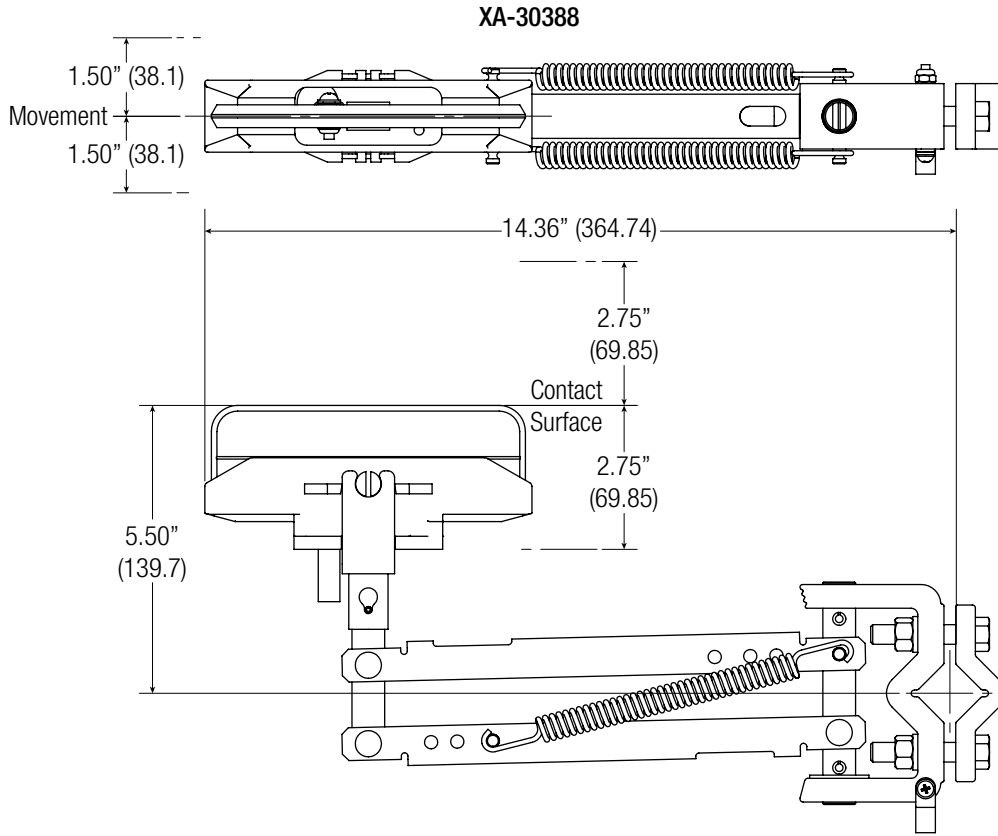

Figure 14-4

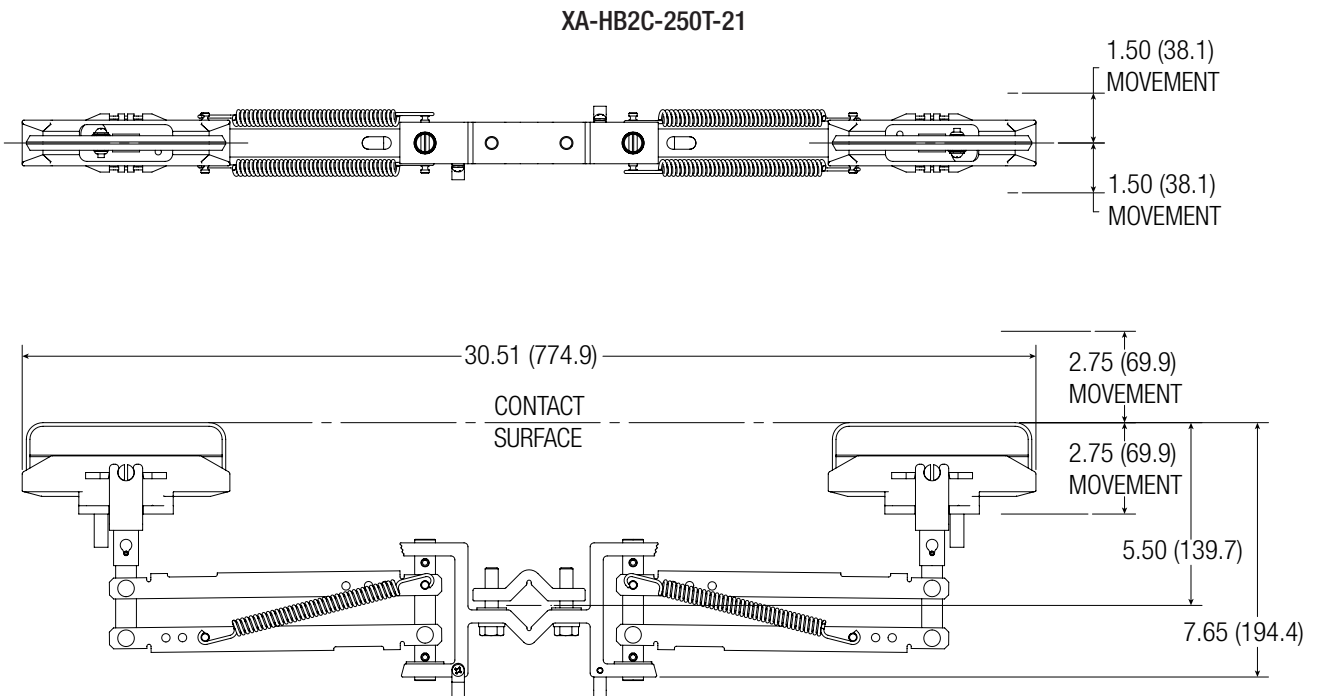

Figure 14-5

SECTION 14 - COLLECTORS

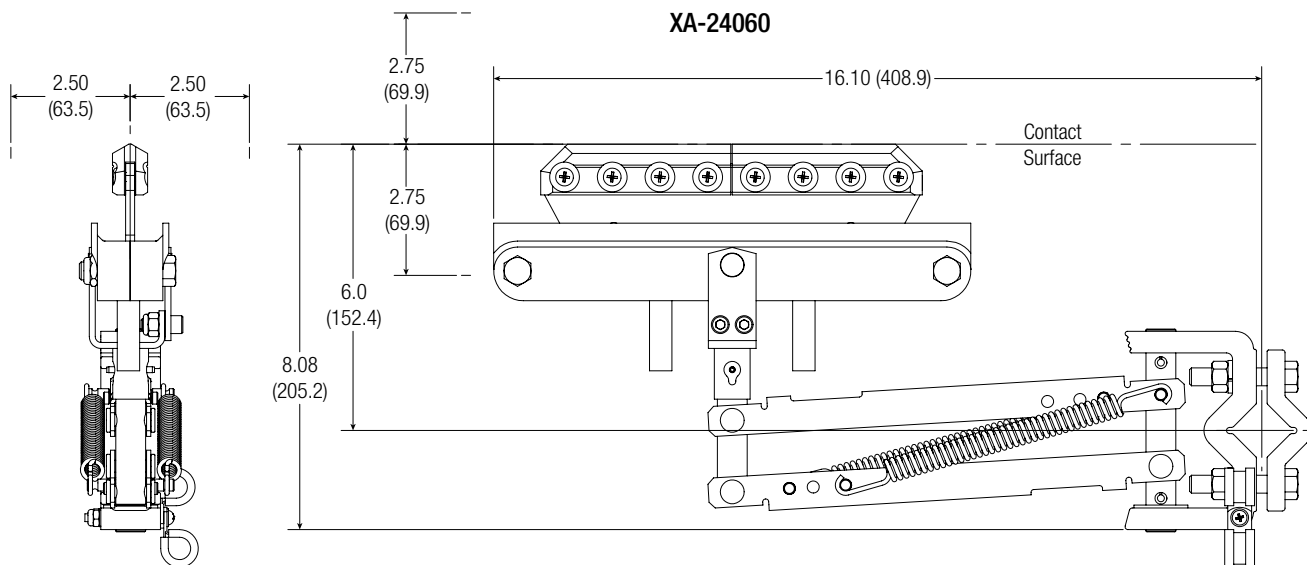

Figure 14-7

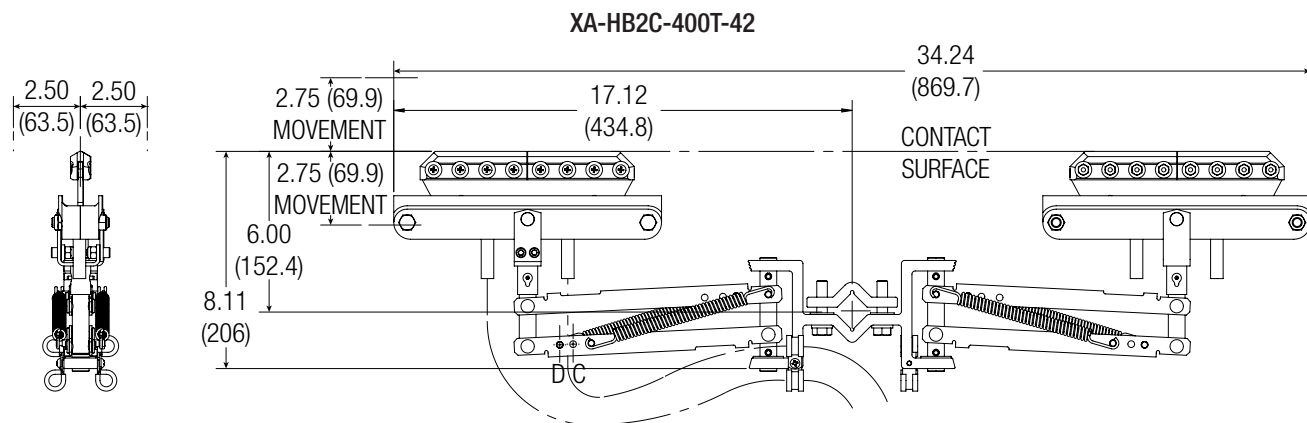

Figure 14-8

SECTION 14 - COLLECTORS

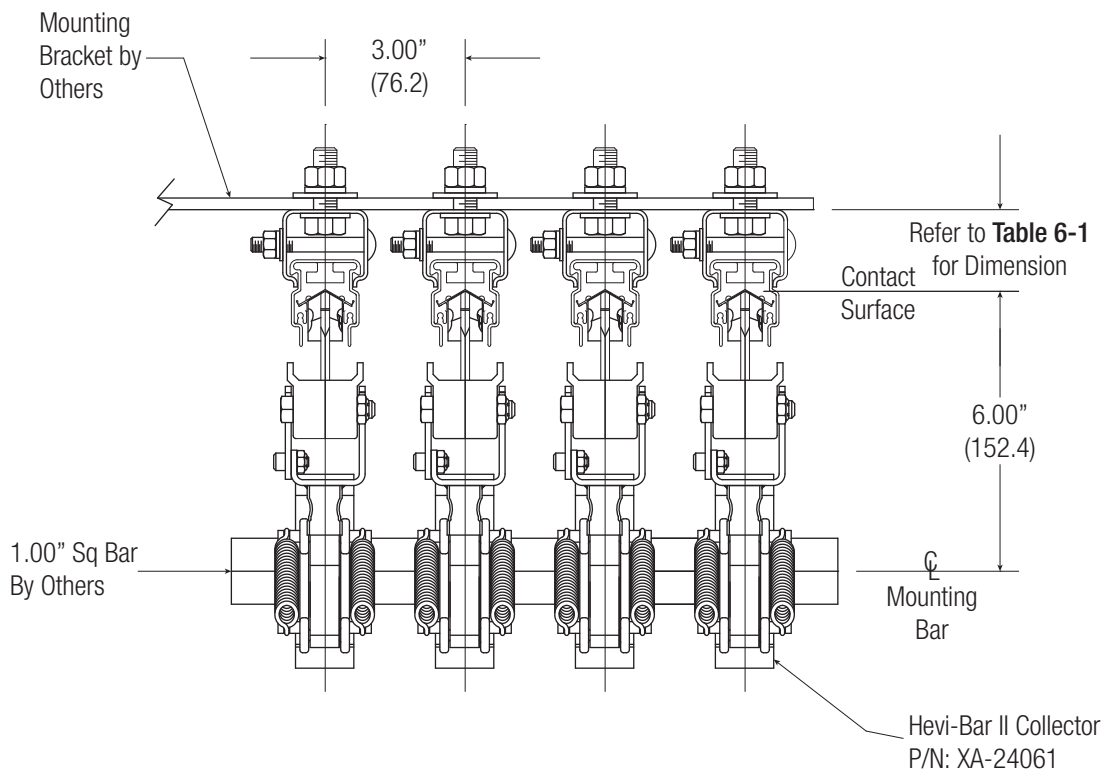

Figure 14-9

SECTION 15 - STANDARD HEAT END COVER KITS

15.0 500 Amp

15.0.1 Locations

15.0.1.1 End covers are used at runway ends to cover exposed conductor bar ends. The following covers are suitable up to medium heat applications up to 250°F (121°C).

15.0.2 Tools Needed

- 7/16" open end wrench
- Torque wrench with 7/16" socket
- Heat gun

15.0.3 End Cover Kits Contents

- Heat shrink tubing, bolt, and nut

15.0.4 Installation

1. With approximately 3.75" (95mm) bar exposed position 1/4" - 20UNC x 0.50" hex head bolt into top slot on bar approximately 3.13" (79mm) from end of bar.
2. Install 1/4" hex nut and tighten with a 7/16" open end wrench.
3. Torque nut with torque wrench to 4-5 ft-lbs.
4. Position heat shrink tubing over end of bar approximately 6.13" (156mm).
5. Using a heat gun shrink tubing over bar and cover.
6. While shrink tubing is warm, press and flatten the excess tubing starting approximately 0.75" (19mm) behind end of bar.
7. When tubing has cooled cutoff excess tubing, leaving approximately 0.75" (19mm) of flattened tubing.

15.1 700 Amp

15.1.1 Locations

15.1.1.1 End covers are used at runway ends to cover exposed conductor bar ends. The following covers are suitable up to medium heat applications up to 250°F (121°C).

15.1.2 Tools Needed

- 1/2" open end wrench
- Torque wrench with 1/2" socket
- Heat gun

15.1.3 End Cover Kits Contents

- Heat shrink tubing, bolt, and nut

15.1.4 Installation

1. With approximately 4.25" (108mm) bar exposed position 5/16" - 18UNC x 0.75" carriage head bolt into top slot on bar approximately 3.00" (76mm) from end of bar.
2. Install 5/16" hex nut and tighten with a 1/2" open end wrench.
3. Torque nut with torque wrench to 10-11 ft-lbs.
4. Position heat shrink tubing over end of bar approximately 8.25" (209mm).
5. Using a heat gun shrink tubing over bar and cover.
6. While shrink tubing is warm, press and flatten the excess tubing starting approximately 0.75" (19mm) behind end of bar.
7. When tubing has cooled cutoff excess tubing, leaving approximately 0.75" (19mm) of flattened tubing.

SECTION 15 - STANDARD HEAT END COVER KITS

15.2 1000/1500 Amp

15.2.1 Locations

15.2.1.1 End covers are used at runway ends to cover exposed conductor bar ends. The following covers are suitable up to medium heat applications up to 250°F (121°C).

15.2.2 Tools Needed

- 1/2" open end wrench
- Torque wrench with 1/2" socket
- Heat gun

15.2.3 End Cover Kits Contents

- Heat shrink tubing, bolt, and nut
- A reference drawing of a standard heat end cover is shown in **Figure 15-1**.

15.2.4 Installation

1. With approximately 6.00" (140mm) bar exposed position 5/16" - 20UNC x 0.75" carriage head bolt into top slot on bar approximately 2.75" (70mm) from end of bar.
2. Install 1/4" hex nut and tighten with a 1/2" open end wrench.
3. Torque nut with torque wrench to 10-11 ft-lbs.
4. Position heat shrink tubing over end of bar approximately 9.50" (241mm).
5. Using a heat gun shrink tubing over bar and cover.
6. While shrink tubing is warm, press and flatten the excess tubing starting approximately 0.75" (19mm) behind end of bar.
7. When tubing has cooled cutoff excess tubing, leaving approximately 0.75" (19mm) of flattened tubing.

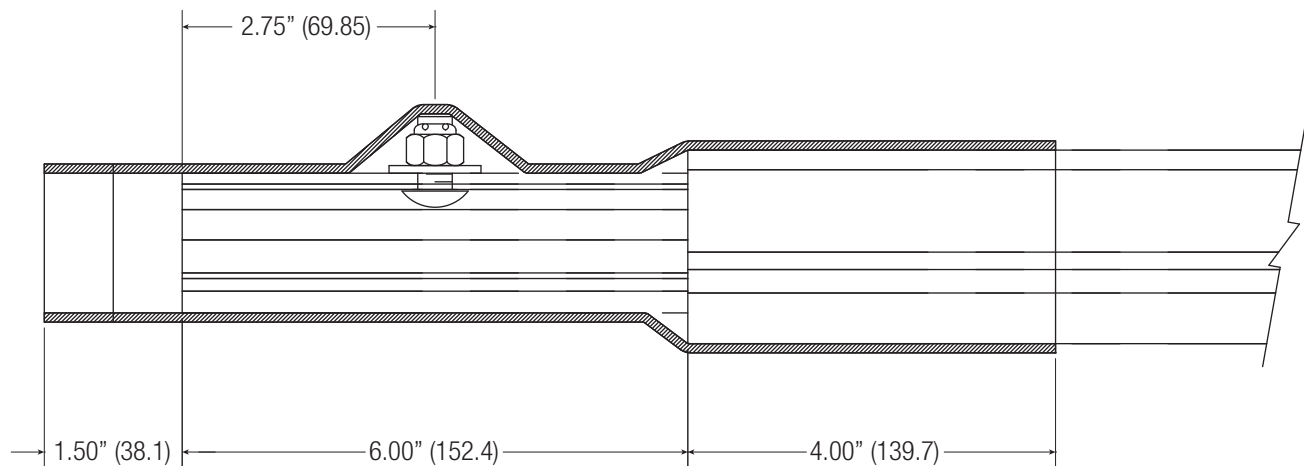

Figure 15-1

SECTION 16 - HIGH HEAT END COVER KITS

16.0 700 Amp

16.0.1 Locations

16.0.1.1 End covers are used at runway end to cover exposed conductor bar ends. The high heat end covers are suitable up to 280°F (138°C).

16.0.2 Tools Needed

- 1/2" open end wrench

16.0.3 End Cover Kits Contents

- Insulating cover, insulating cover clamp, bolt, nut and washer
- A reference drawing of a high heat end cover is shown in **Figure 16-1**.

16.0.4 Installation

1. With approximately 4.25" (108mm) bar exposed slide a 10.0" (254mm) conductor bar cover on conductor bar bare end. Leave excess cover hang over the edge of bar.
2. Slide the overlap cover over bar and cover. Make sure the outer ends of the cover and overlap are even.
3. Install hardware into clamp using one 5/16"-18UNC x 2.75" carriage bolt, 5/16" flat washer, and 5/16" flexloc hex nut.
4. Position clamp underneath bar approximately 3.0" (76mm) from end and tighten 5/16" flexloc nut with a 1/2" open end wrench until cover is firm.

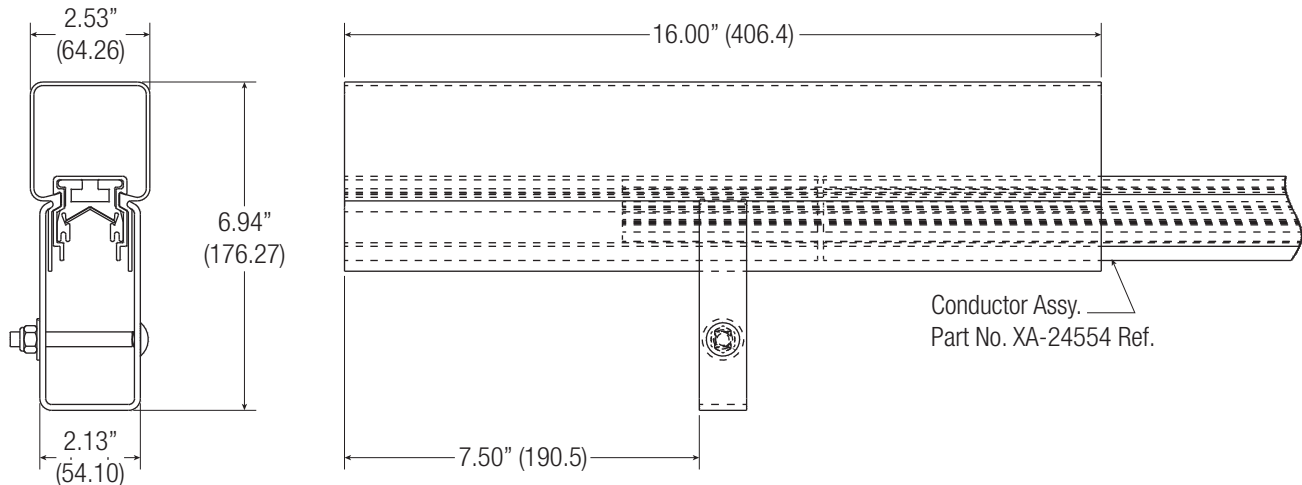

Figure 16-1

SECTION 16 - HIGH HEAT END COVER KITS

16.1 1000 Amp

16.1.1 Locations

16.1.1.1 End covers are used at runway ends to cover exposed conductor bar ends. The high heat end covers are suitable up to 280°F (138°C).

16.1.2 Tools Needed

- 1/2" open end wrench
- Torque wrench with 1/2" socket

16.1.3 End Cover Kits Contents

- Insulating cover, "L" shape clamp, bolt, nut, and washer
- A reference drawing of a high heat cover is shown in **Figure 16-2**.

16.1.4 Installation

1. With approximately 6.00" (140mm) bar exposed position 5/16"-20UNC x 1.0" carriage head bolt into top slot on bar approximately 4.5" (114mm) from end of bar.
2. Install "L" shape clamp on carriage bolt with leg upward and slide toward conductor bar cover.
3. Install 5/16" hex nut and tighten with a 1/2" wrench.
4. Torque nut with torque wrench to 10-11 ft-lbs.
5. Snap overlap cover assembly, with short end toward conductor bar, over conductor bar and cover with "L" shape clamp positioned between overlap cover pins.

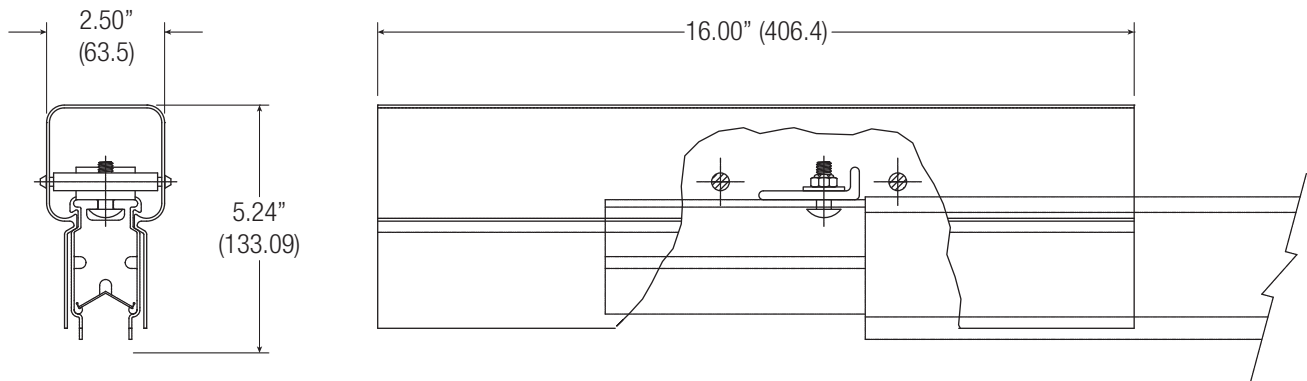

Figure 16-2

SECTION 17 - INSPECTION AND MAINTENANCE

17.0 Overview

17.0.1 Proper system performance and reliability require thorough periodic system maintenance. Each component of the system must be inspected, at a minimum annually. Many components require more frequent inspection and possibly maintenance, see Table 17-1. Bolt torque, cable connection integrity, insulating material integrity, and collector alignment and shoe wear are among the primary areas of concern.

WARNING

All power must be disconnected from the conductor bar prior to performing any inspection or maintenance. Proper lockout/tag-out procedures must be followed.

Should questions or concerns arise regarding the condition of the system or its components, call Conductix-Wampfler at: (800) 521 4888

17.1 Frequency

	Component	Frequency
1	Covers	Semi-annually
2	Hanger Clamps	Semi-annually
3	Conductor	Semi-annually
4	Splice	Semi-annually
5	Anchor	Semi-annually
6	Expansion	Semi-annually
7	Power feed	Semi-annually
8	End Cap	Semi-annually
9	Collector Assemblies	2 weeks after initial installation then Quarterly

Table 17.1

17.2 Covers

17.2.1 All covers (conductor and component overlap covers) shall be inspected semi-annually. The integrity of the cover is critical. Damage to the cover in the form of cracks, splits, or holes requires replacement.

17.2.2 Inspect the visible outside surfaces of the conductor and overlap covers for signs of damage. Replace as necessary.

17.3 Hanger Clamps

17.3.1 Check the hanger clamps to ensure there are no cracks or fractures in the molded plastic clamps. Replace components as necessary.

17.3.2 Check bolt torque per drawing. This can be a random sampling of 2 hanger clamps between each set of anchors (distance between anchors is approximately 195' from the starting end succeeding anchor points at 156' maximum for 110°F temperature range). If the hardware is not a minimum of 15 ft-lbs, all the hardware between those 2 anchors must be checked and/or properly torqued.

17.3.3 For systems using hanger clamps with cross bolts, verify there is .02-.05 inch clearance between the hanger clamp and the conductor bar.

SECTION 17 - INSPECTION AND MAINTENANCE

17.4 Conductors

17.4.1 All conductors shall be inspected semi-annually.

17.4.2 Inspect the contact surfaces and open area inside the cover for any debris and abnormal wear in 150 foot intervals (every 5th conductor). This will give a good overall indication of the degree of debris accumulation throughout the system.

17.5 Splices

17.5.1 Remove covers and check bolt torque. **Hardware must be 6FT-LBS for 500A bar, 11FT-LBS for 700A-1500A bar.**

17.5.2 If bolts are loose, remove the splice plate and check for signs of burning or arcing between the conductor and splice plate. Replace damaged components as required following the installation instructions. Apply conductive grease when reinstalling splices.

17.5.3 Check overlap covers and end caps for signs of damage. Replace as required.

17.6 Anchor Clamps

17.6.1 Check the anchor clamps to ensure there are no cracks or fractures in the molded plastic clamps or damage to the stainless steel hangers. Replace components as necessary.

17.6.2 Check bolt torque per **Table 6-2**, all the hardware must be checked and/or properly torqued.

17.6.3 If system is equipped with anchor pins, check to insure pins are not missing or broken. If pins are found missing, insert new anchor pins. If the pins are not a force fit, use RTV sealant to insure the pin is properly secured.

17.6.4 For systems using hanger clamps with cross bolts, check torque at anchor locations is 60 in.-lbs.

17.7 Expansions

17.7.1 All expansions shall be inspected semi-annually.

17.7.2 Inspect the contact surfaces and open area inside the cover from any debris and abnormal wear. Verify there are no obstructions in the slots that will inhibit movement. Grab the block and determine if it is loose. Look for evidence of shoes hitting block. This could indicate that the block has come loose and will make shoes jump out of contact with conductor. The slider may have to be replaced.

17.8 Power Feeds

17.8.1 Remove covers and check bolt torque to ensure it is properly torqued to **6FT-LBS for 500A bar, 11FT-LBS for 700A-1500A bar.** If bolts are loose, remove the powerfeed plate and check for signs of burning or arcing between the conductor and powerfeed plate. Replace damaged components as required following the installation instructions. Apply conductive grease when reinstalling powerfeeds. Check overlap covers and end caps for signs of damage. Replace as required. Check to ensure the grommets are located securely in the end plugs. Check cables for abrasion or damage to the jackets. Replace as required.

17.9 End Caps

17.9.1 Inspect the cover on the end cap for damage in the form of cracks, splits, or holes. Replace as necessary.

17.10 Collectors

17.10.0.1 Inspect quarterly for signs of cracks, wear, damage, dirt accumulation, or anything that would indicate an item or the assembly needs to be replaced. At a minimum, the inspection should include:

17.10.1 Collector Arms

- Inspect for cracks, deformation, or any other evidence of damage. Collector arm should be replaced at least every 5 years.

17.10.2 Mounting Brackets and Bolts

- Verify collector mounting base is square on the vehicle and it is aligned with the conductor.

SECTION 17 - INSPECTION AND MAINTENANCE

17.10.3 Tension Springs

- Spring is properly positioned on the pin in the collector arm. Check contact force and nominal distance between the mounting surface and contact surface (contact Conductix-Wampfler for force requirement). A “fish scale” may be used to check this. Hook the scale on the collector arm as close to the shoe-end of the collector. Pull the scale. The contact force is the force at which the arm begins moving away from the conductor. Replace if spring tension is not correct.

17.10.4 Spring Pins

- Inspect for cracks, deformation, or any other evidence of damage. Verify all are in place.

17.10.5 Cables

- Cable length between lug on shoe and cable clamp on arm is per the drawing. Cable routing to vehicle must allow free movement of collector throughout its complete range of motion. Check that cables are properly terminated to the vehicle (specification by others).

17.11 Shoe Holders

17.11.1 Inspect for cracks, deformation, or any other evidence of damage.

17.11.2 Verify that all retaining rings and E-rings are securely in place.

17.11.3 Inspect the shoes weekly for wear and damage. Replace shoes when height, measured at any location along shoe, is 3/8” or less.

17.11.4 If a broken shoe is found, inspect the system for the cause. Broken shoes usually result from:

- Insufficient contact force causing the shoe to bounce excessively - replace the spring as required.
- Gaps at the splice joint - loosen splice hardware and butt conductors, tighten fasteners and torque to **6FT-LBS for 500A bar, 11FT-LBS for 700A-1500A bar.**
- Misalignment between adjacent conductors - realign as required.
- Misalignment between the vehicle and conductor bar pulling the collector beyond its maximum horizontal and/or vertical envelope - this usually happens around curves in the conductor bar or in locations where hanger clamps and/or mounting brackets are not properly aligned. Realign as necessary.
- Inspect the shoes for uneven wear - uneven wear can be an indication of insufficient contact force or bias on a shoe due to cable routing, incorrect location of the tension spring, or misalignment. Uneven shoe wear, if not corrected, can wear the side of aluminum resulting in the stainless steel contact surface coming loose. Both ends of the shoe must be checked for uneven wear.

SECTION 17 - INSPECTION AND MAINTENANCE

17.12 Collector Shoe Replacement

17.12.1 Due to a wide variety of applications and environmental conditions, no time frame is given for shoe replacement. It is recommended however that the customer do periodic inspections of the collector heads to check for shoe wear. If the contact surface of the shoe reaches the wear-line the shoe should be replaced immediately. The shoe should also be replaced immediately if it shows signs of overheating, is pitted, cracked or chipped. If the wear pattern on the shoe is more than 10 degrees off even, the shoe should be replaced and the collector mounting position should be re-evaluated. A minimum of 0.18" (3/16") to the nearest cover component (including overlap covers) should always be maintained.

17.12.2 Several conditions may lead to accelerated shoe wear. The most common conditions are:

1. A loss of contact with the conductor surface creates an overheating situation which will cause pitting in the conductor surface. This pitting further reduces electrical contact, exacerbating the overheat condition and in turn, creates more pitting. Improper installation may prevent the collectors from maintaining adequate contact with the conductor contact surface along part or all of the complete length of the runway. This may be due to:
 - Poor alignment of the conductor mounting brackets in the vertical and horizontal planes - in this case the collectors do not have enough travel to maintain good contact because the conductors do not stay within the optimal contact range of the collector.
 - Improper location of the collector mounting bracket relative to the conductor (too close or too far away) - too far away creates too little contact pressure and too close may cause the shoe to nose or drag on the end.
 - Restricted movement of collector heads - it is essential that the collector pigtails (feed cables) to the shoes have adequate free loop to allow rotation of the collector head throughout the full range of motion. Too-short pigtails can prevent good shoe contact and cause loss of contact.
 - Loosening of conductor joints - when too few expansion sections are used or when anchor clamps are loose, the conductor joints may separate. The gaps in the conductor contact surface cause by this separation can shave the shoes down and cause premature wear. If not detected in time, poor contact may result, creating overheating, pitting of the conductor etc.
2. Contaminants in the environment may accumulate on the conductor contact surface. These contaminants need not be electrically insulating to cause problems; if they decrease the area of contact between the shoes and conductor, problems may arise with overheating, pitting, etc. Some contaminants may be abrasive, increasing the rate of wear on the shoes.
3. Corrosive elements may create deposits on the collector shoe and/or the conductor contact surface thus decreasing conductivity at the sliding contact surface. Under severely corrosive conditions, the copper graphite shoes may be corroded to the point where less than half of the shoe is remaining, decreasing the available contact surface area and causing overheating and pitting.
4. Infrequent maintenance of the collectors can lead to worn-out shoes, poor contact, pitting etc.

SECTION 18 - TROUBLESHOOTING

Problem	Possible Cause(s)	Possible Solution(s)
Overheating/Burning Conductor	Loose splice	Disassemble component, clean mating surfaces, apply EJC, and re-torque hardware replacing Belleville washers and nuts.
	Loose power feed and/or lug(s)	
	Overloading	Check electrical loading by doing a load survey. Rectify if not according to system parameters.
Arcing/pitting on the stainless steel insert at the splice	Loose splice	Disassemble component, clean mating surfaces, apply EJC, and re-torque hardware replacing Belleville washers and nuts.
	Misaligned conductors resulting in the copper shoe losing contact	Disassemble component, clean mating surfaces, apply EJC, realign conductors, and re-torque hardware.
Arcing/pitting on the stainless steel insert	Collector not making good contact with conductor	<p>Check alignment of conductor with respect to vehicle. Adjust position of hanger clamp and/or hanger bracket.</p> <p>Verify contact force of collector is 17-23 lb. Replace tension spring on collector arm. Investigate stainless steel insert for debris and/or misaligned splice joints causing collector to bounce. Remove debris and/or align conductor in splice.</p> <p>Check vehicle's running surface for anything causing sudden lurch of the vehicle or excessive vibration. Adjust as necessary.</p>
Arcing/pitting on the stainless steel insert at an isolation	Large voltage potential between both side of the isolation	<p>Check for debris and/or misaligned isolation joint causing the collector to bounce. Remove debris and/or align conductors adjusting for a smooth transition of the collector shoe as required.</p> <p>Splice short pieces of conductor on either side of the isolation that can be easily replaced when worn out.</p> <p>Compare voltage drop from feed points on either side of the isolation. Adjust the location of the power feeds if possible.</p>
Conductor binding/snaking in between hanger clamps	Hanger clamp not "squared" with the conductor	Loosen hardware on hanger clamp, make square with conductor and re-torque. Check for debris and/or cracks in cover impeding expansion and contraction of conductor. Remove debris with compressed air and/or water. Replace cover if necessary.
	Expansion gap set incorrectly	Measure expansion gap and adjust according to the gap setting chart.
	Anchor clamp not tight	<p>Check torque of the hardware on the anchor. Re-torque as required.</p> <p>Check anchor clamps and verify none are cracked or fractured. Replace as necessary.</p>

SECTION 18 - TROUBLESHOOTING

Problem	Possible Cause(s)	Possible Solution(s)
Shoe Chipping on leading edge	Misaligned splice, power feed, and/or isolation	Check alignment of conductor joints at splice, power feed, and isolations by running a shoe across the joint by hand. Adjust alignment of conductors as required.
	Insufficient contact force of shoe on conductor resulting in the shoe “tipping” up on the bar and impacting the leading edge	Verify correct position of collector base to contact surface then measure the contact force of the shoe on the conductor with a spring scale. Contact force should be 17-23 lbs. Replace spring if necessary.
Excessive shoe wear	Misaligned splice, power feed, and/or isolation	Check alignment of conductor joints at splice, power feed and isolations by running a shoe across the joint by hand. Adjust alignment of conductors as required.
	Arcing/pitting on the stainless steel creating a rough surface	See “arcing/pitting on the stainless steel insert” above.
Uneven shoe wear on leading edge vs. trailing edge	Insufficient contact force of shoe on conductor resulting in the shoe “tipping” up on the bar and impacting the leading edge.	Verify correct position of collector base to contact surface then measure the contact force of the shoe on the conductor with a spring scale. Contact force would be 17-23 lbs. Replace spring if necessary.
	Misaligned splice, power feed, and/or isolation impacting shoe in one direction	Check alignment of conductor joints at splice, power feed, and isolations by running a shoe across the joint by hand. Adjust alignment of conductors as required.
Uneven shoe wear on sides of shoe	Incorrect position of tension spring on collector	Position hook of spring in top slot of pin in base so spring is pulling the collector shoe into the conductor and “up” from the running surface (refer to collector drawing).

NOTES

www.conductix.us

Conductix-Wampfler

has just one critical mission:
To provide you with energy and
data transmission systems that
will keep your operations up
and running 24/7/365.

To contact your nearest
sales office, please refer to:

www.conductix.contact

